

ARTIFICIAL ORGANS

- Replacement of a hole or a part of an organ to achieve a more physiological function.
 - Active – passive systems.
- Organs in broad clinical use
 - Heart
 - Lungs
 - Kidney
 - Skin
 - Joints
- Organs under development
 - Sensing organs
 - Pancreas
 - Liver

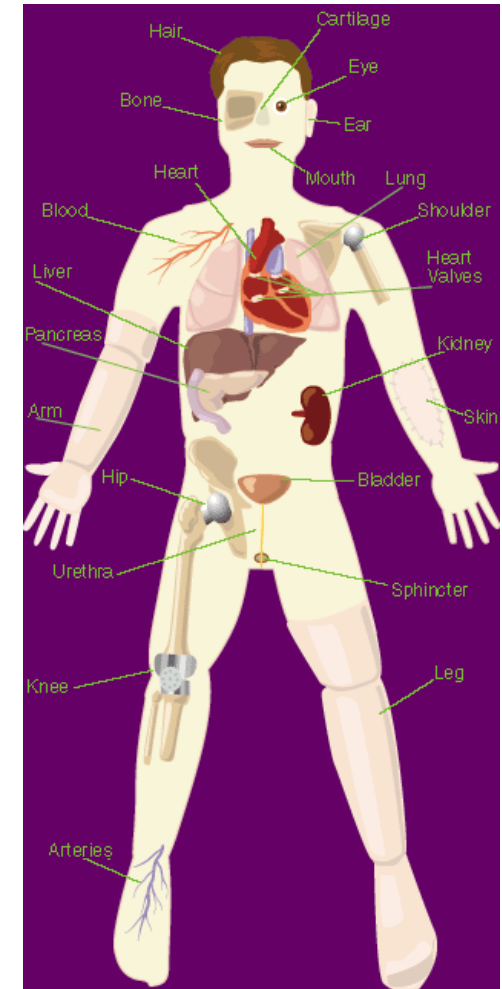
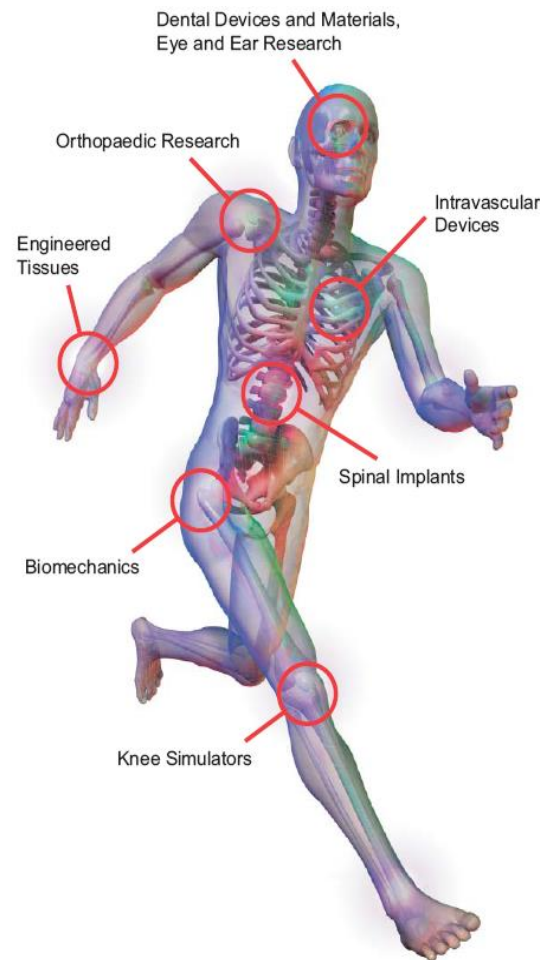

Cardiovascular system

- Active systems
 - Total Artificial heart (TAH)
 - Ventricular assist devices (VAD)
 - » Right ventricle (RVAD)
 - » Left ventricle (LVAD)
 - Blood pumps
- Passive systems
 - Artificial heart valves
 - » Mechanical valves
 - » Biological valves
 - Artificial blood vessels
 - Vascular stents: Coronary – peripheral circulation

Circulatory system

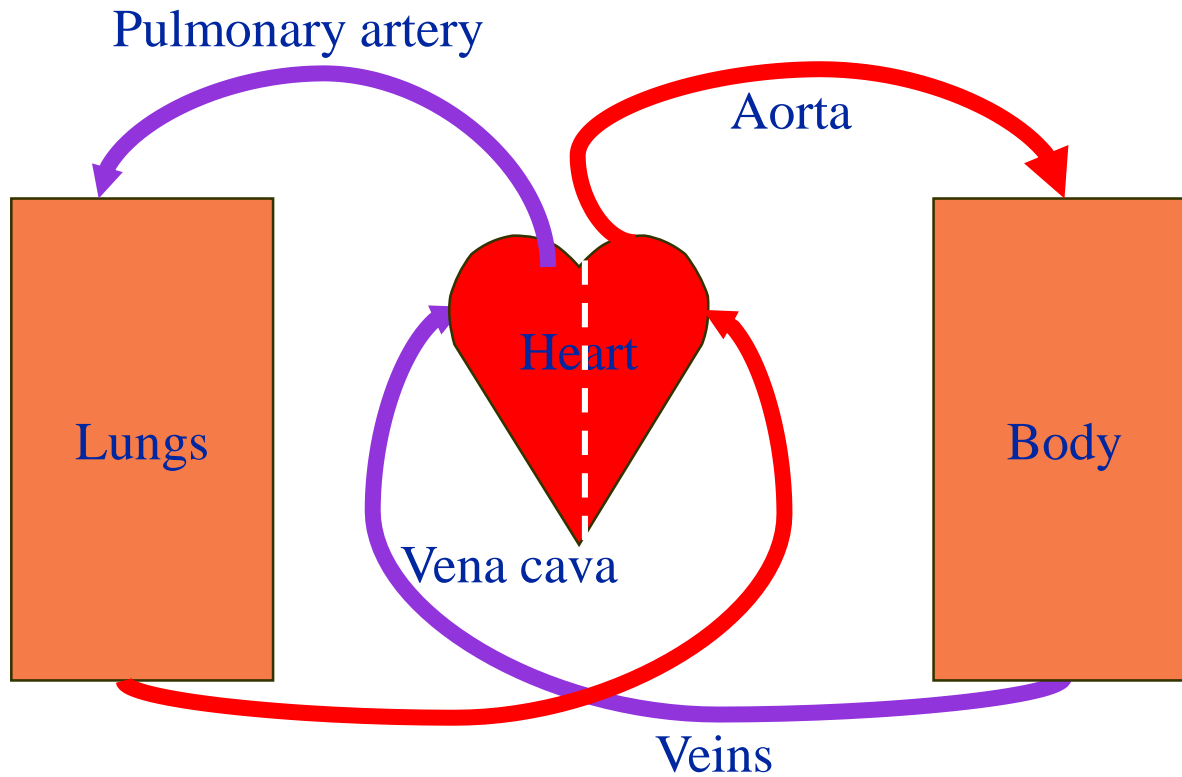

Heart function

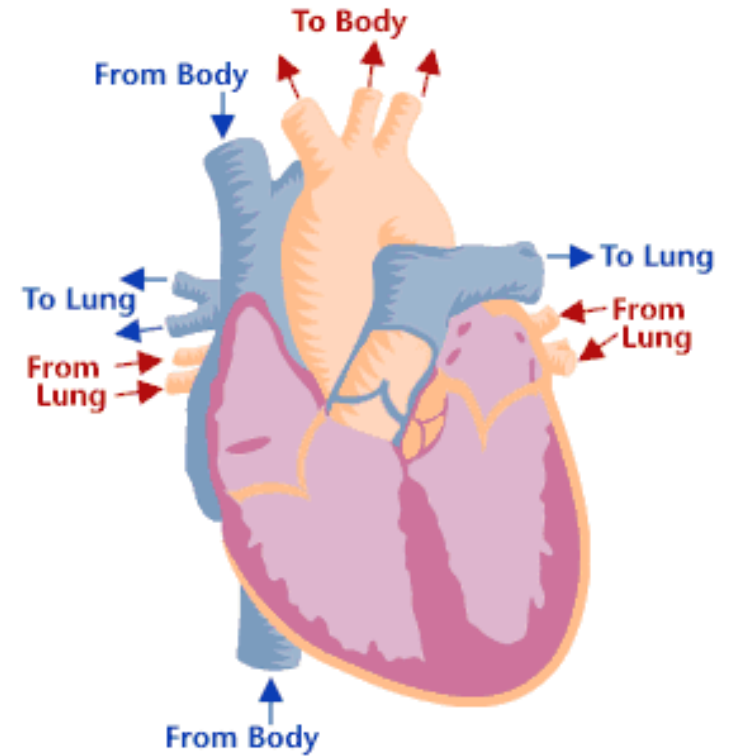
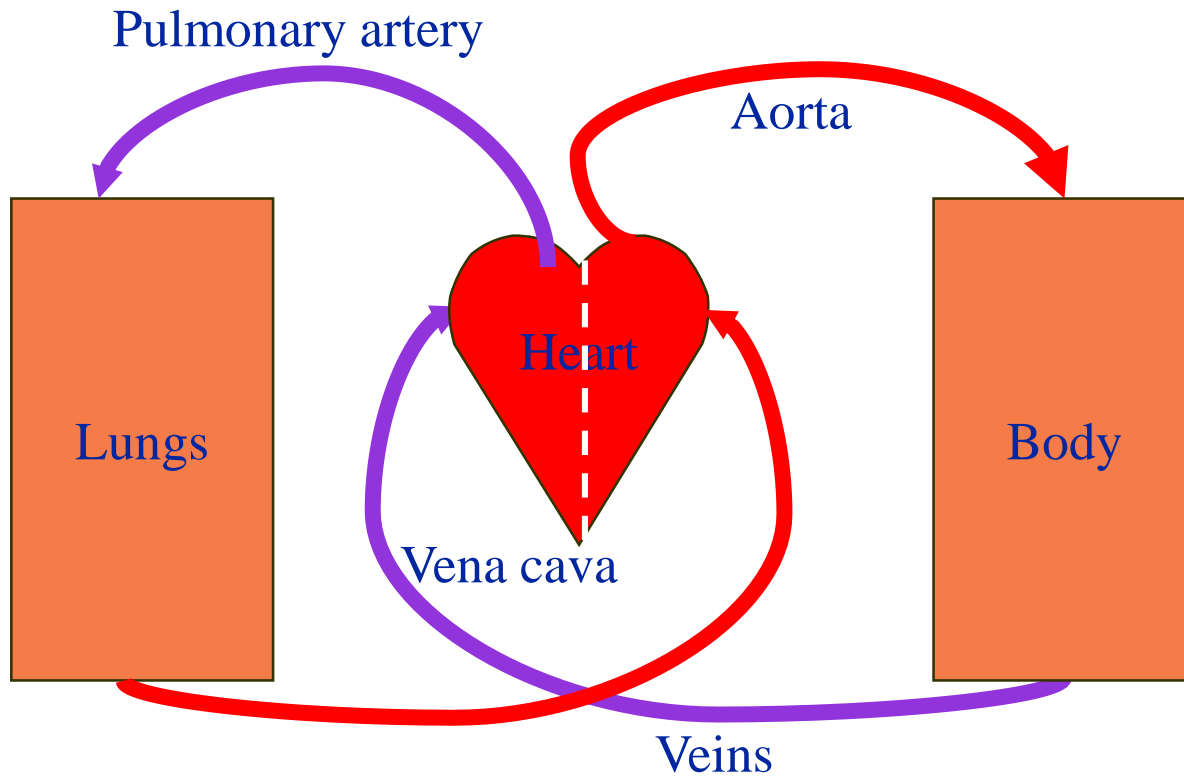

The heart

Heart

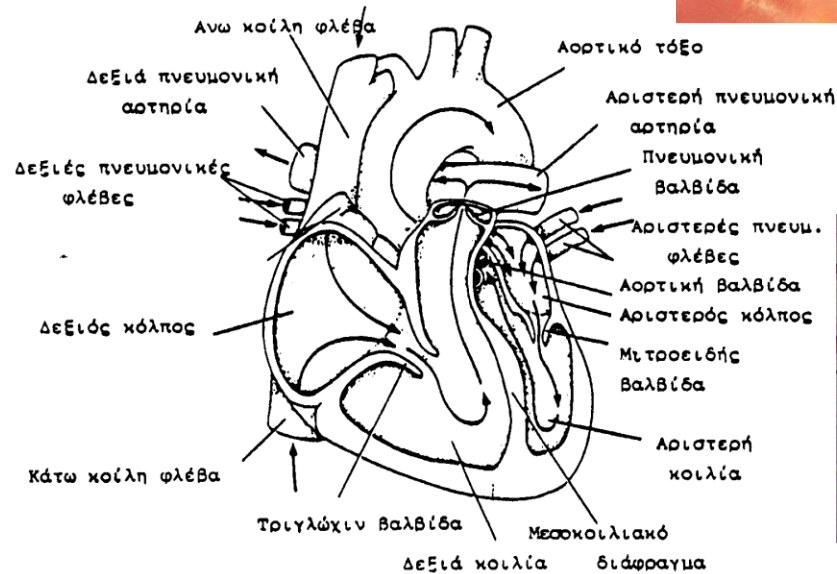
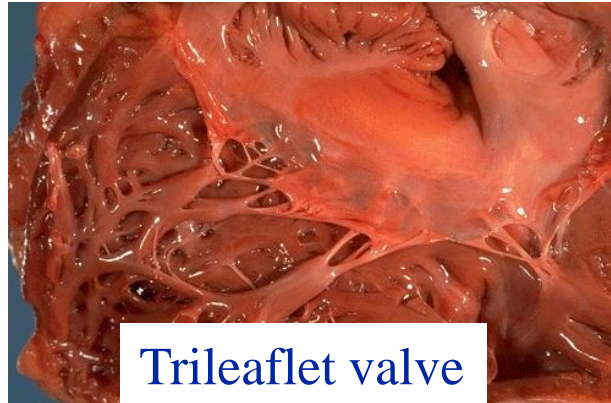

Aortic valve

Coronary artery

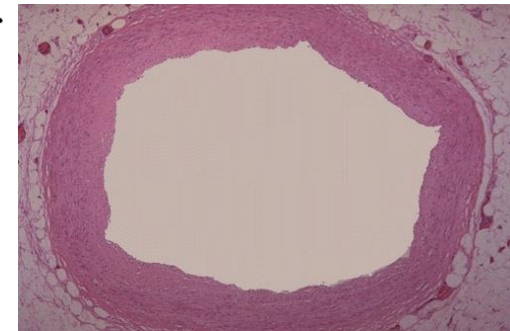

Σχ. 1 Αναπαράσταση της καρδιάς. Τα βέλη δείχνουν τη διαδρομή του αίματος στα διάφορα τμήματά της (Snell, R.S. 1984: Histology for medical students, Little, Brown and Comp. Boston).

Cardiovascular pathology

Aortic valve calcification

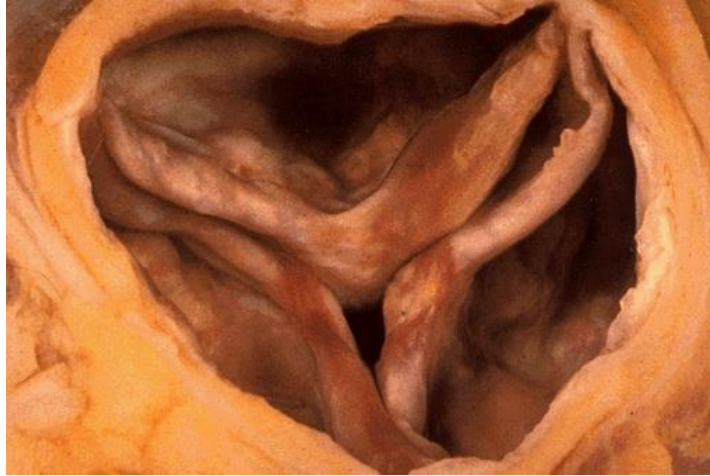

Bileaflet aortic valve-calcified

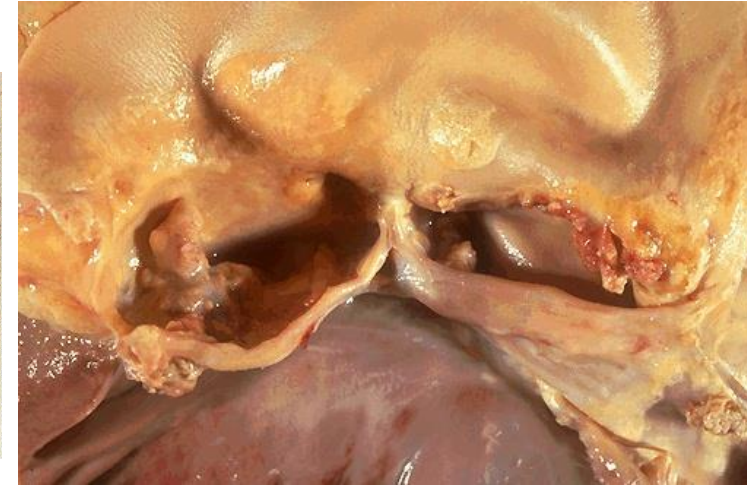
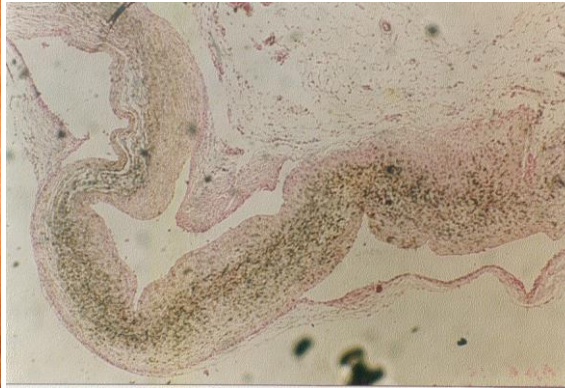

Mitral valve. Aortic ring calcification



Infective endocarditis

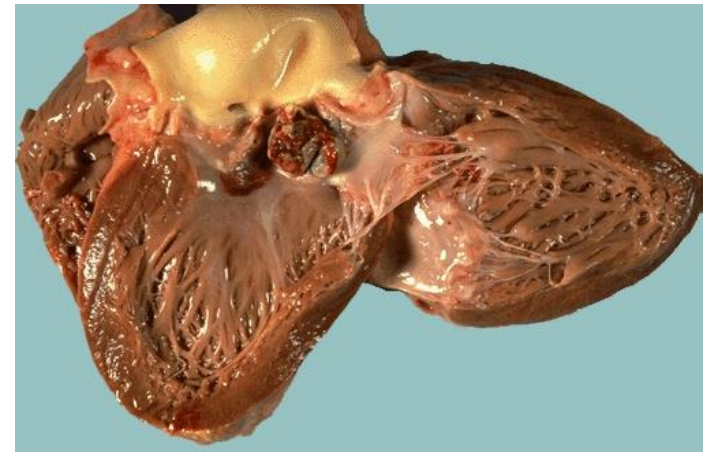

Cardiovascular pathology

Atheromatic aneurism of abdominal aortaç

Aortic atheroma

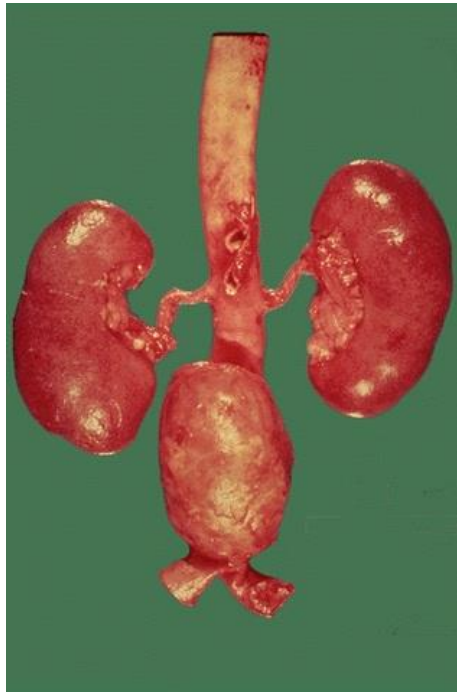

Atheroma of coronary artery

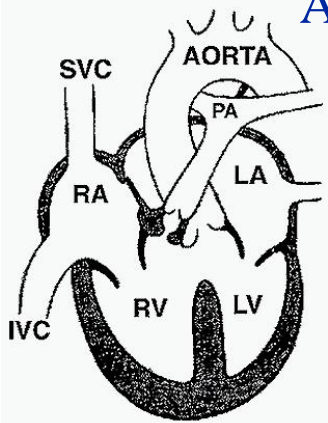
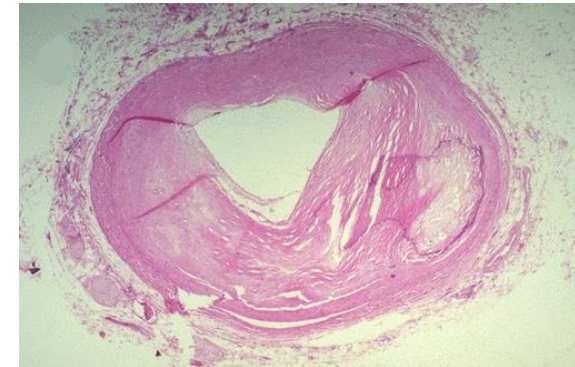

Congenital heart diseases

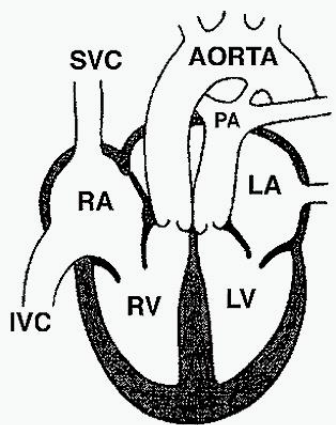

Donor transplantation

- Difficult to find donors
- Availability - burrocracy
- Conditions
- Equipment – experience
- Distance – transportation
- Compatibility
-
- As a result, even ideally, less of 10% of clinical needs can be covered worldwide

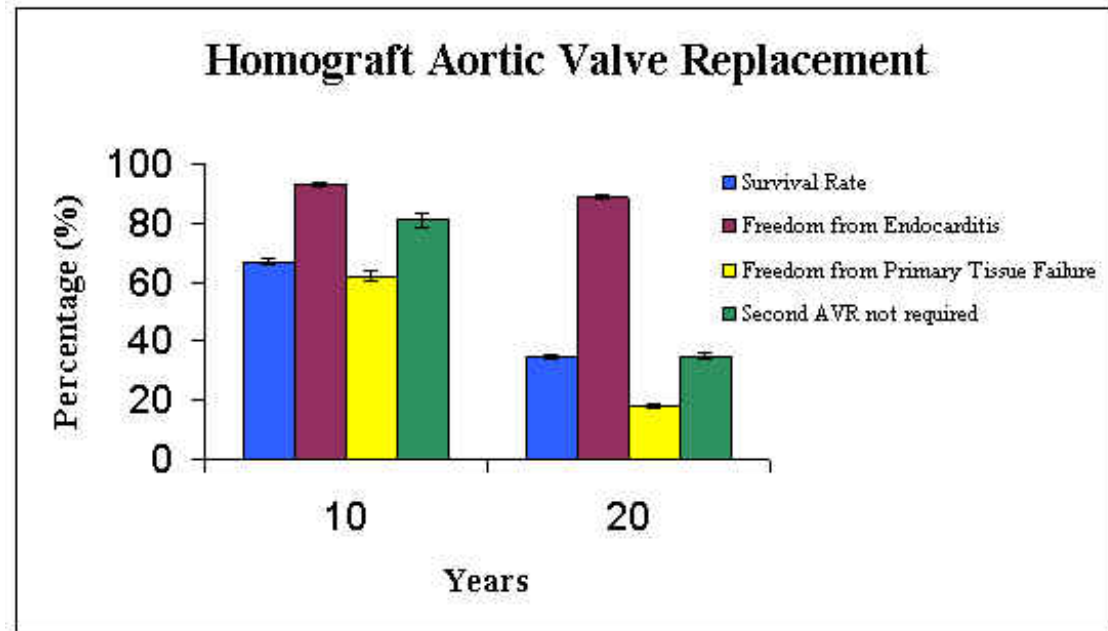

Organ replacement

Artificial organs

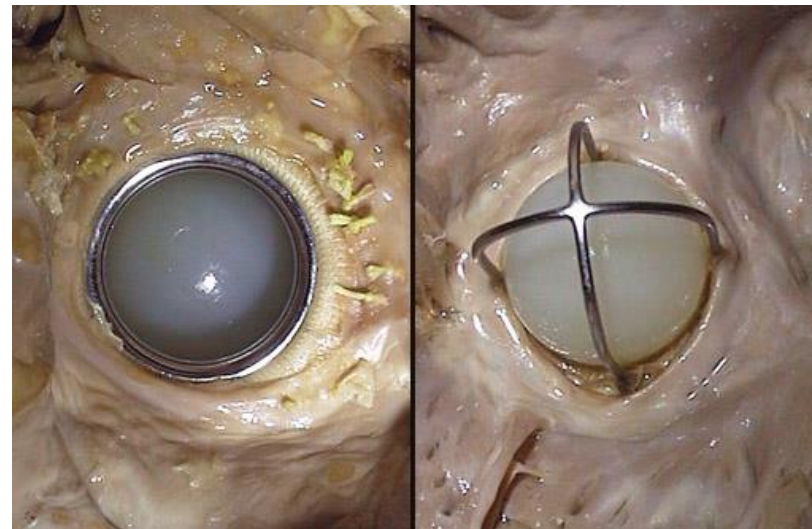
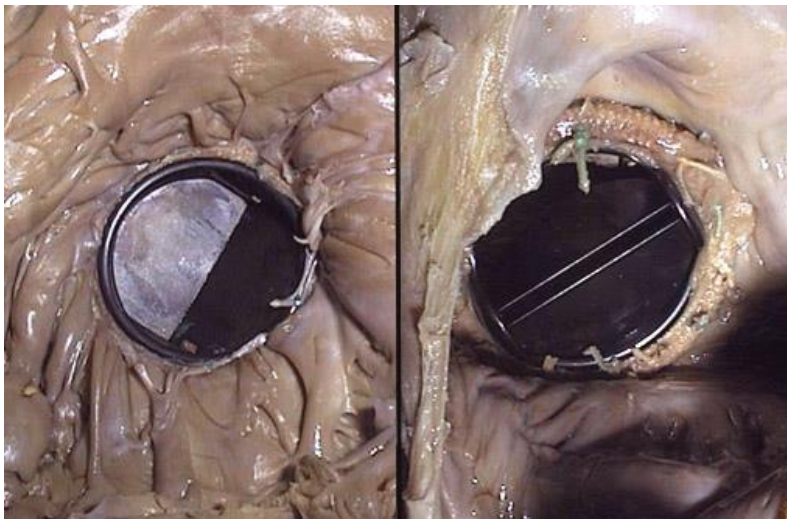
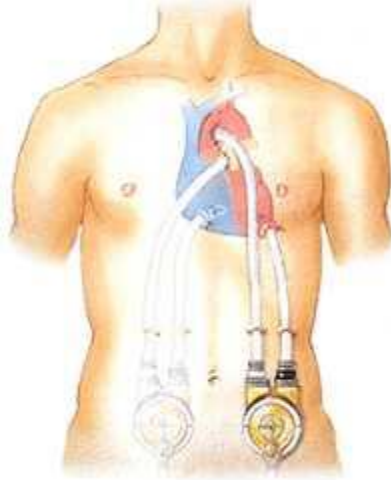

Artificial heart valves

- Passive systems to secure quite physiological unidirectional blood flow
- Heart valve replacement according certain patients' score indexes (e.g. NYHA)
- Estimation of proper type (mechanical – biological), design, anatomical characteristics
- Post implantation (various techniques) short – mid – long time patient check up
- Short or for life drug therapy – support (e.g. anticoagulation)
- **AS A RESULT:** Patient never lives a normal life, even if physiological function is recovered.

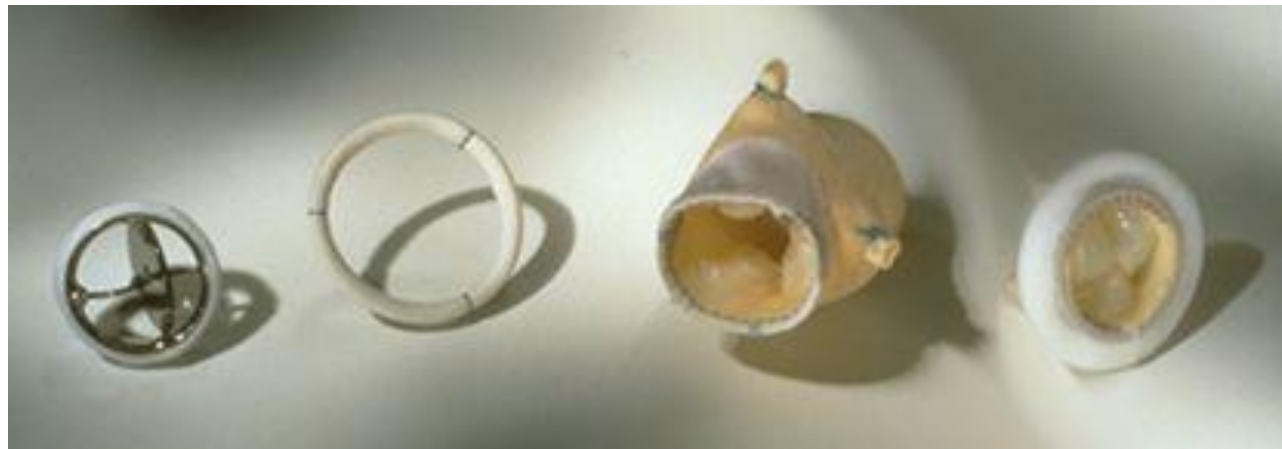

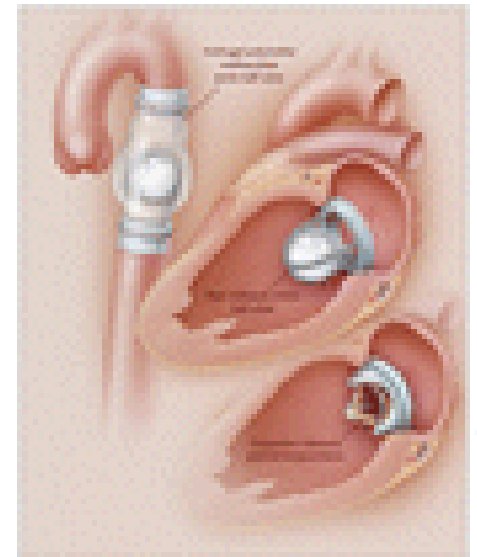

Artificial valves: evolution

- ❑ 1952: First implantation (Charles Hufnagel) Plexiglass-Nylon_silicon. Descending aorta
- ❑ 1953: 1st open heart surgery: oxygenators, deaeration. New biomaterials
- ❑ 1955: 1st implantation in aortic anatomic position (Sheffield UK). Death after 14 hrs (ball movement)
- ❑ 1961: Starr-Edwards valve. Long term survival in 6 out of 8 patients
- ❑ End of 60s: Carpentier's stent mounted bioprosthetic heart valve.



Types of prosthetic valves

Valve type	Advantages	Disadvantages
Mechanical 	<ul style="list-style-type: none">• Longevity• Easy implantation• Variety of size-designs• Availability	<ul style="list-style-type: none">• Non physiological geometry - hemodynamic• Chronic anticoagulation therapy• Risk of thromboembolism• Regular medical examinations
Bioprosthetic 	<ul style="list-style-type: none">• Physiological anatomy - hemodynamic• Minimize anticoagulation therapy• Availability	<ul style="list-style-type: none">• Tissue deterioration• Calcification• Undesirable host reactions
Living grafts	<ul style="list-style-type: none">• Ideal anatomy - hemodynamic• Physiological remodeling• Minimal anticoagulation therapy	<ul style="list-style-type: none">• Tissue deterioration• Calcification• Minimal availability• Undesirable immunologic reactions

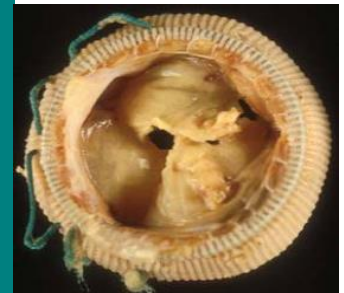

Mechanical valves

- Various designs regarding closing mechanism:
 - Caged ball
 - Caged disk
 - Tilting disk
 - Bileaflet (even trileaflet?)
- Anatomical position:
 - Aortic (LV)
 - Mitral (LV)
 - Pulmonary (RV)
 - Trileaflet (RV)



Heart valve replacement techniques

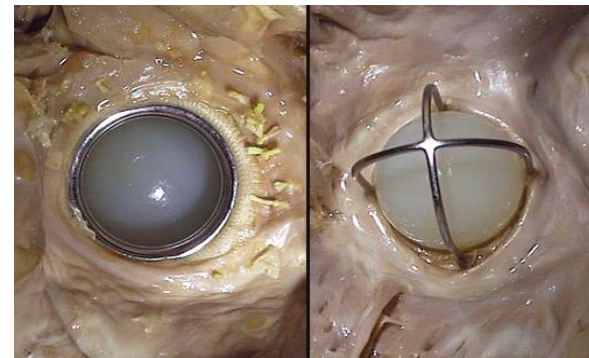
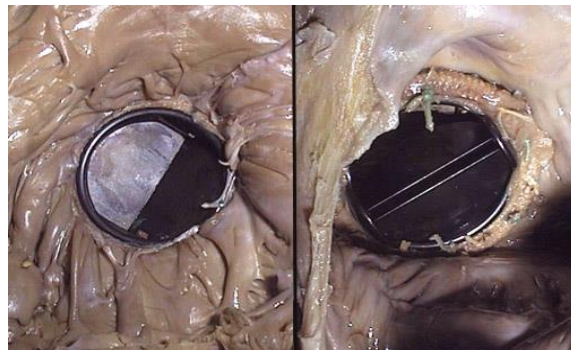
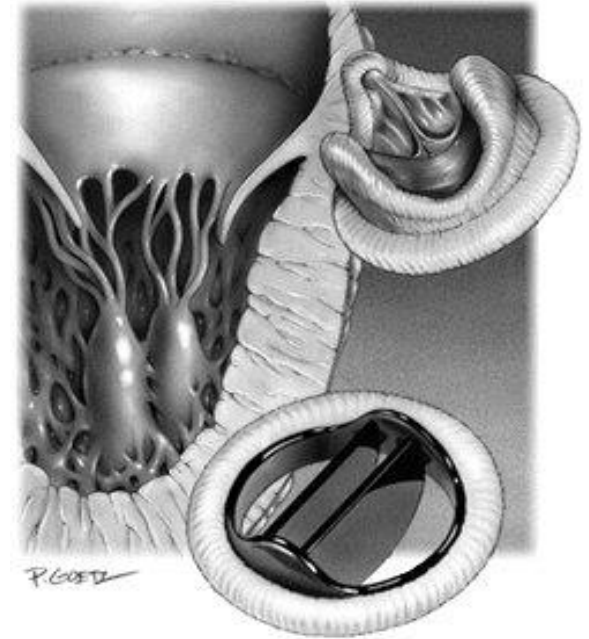
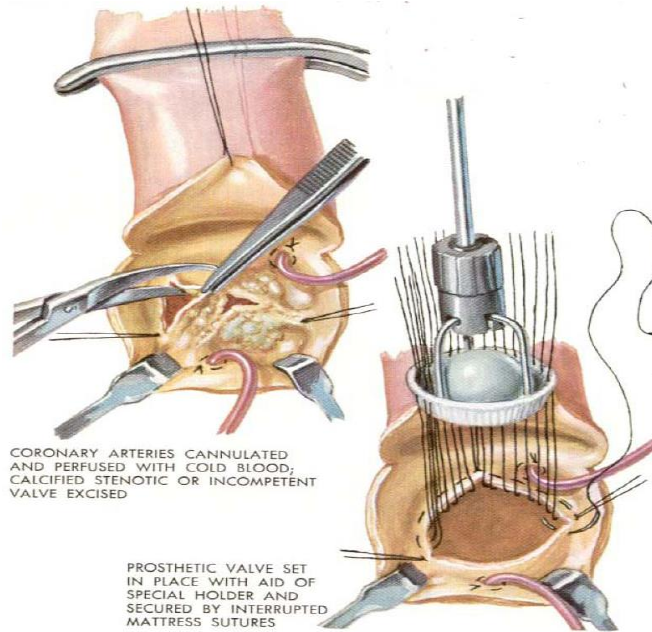
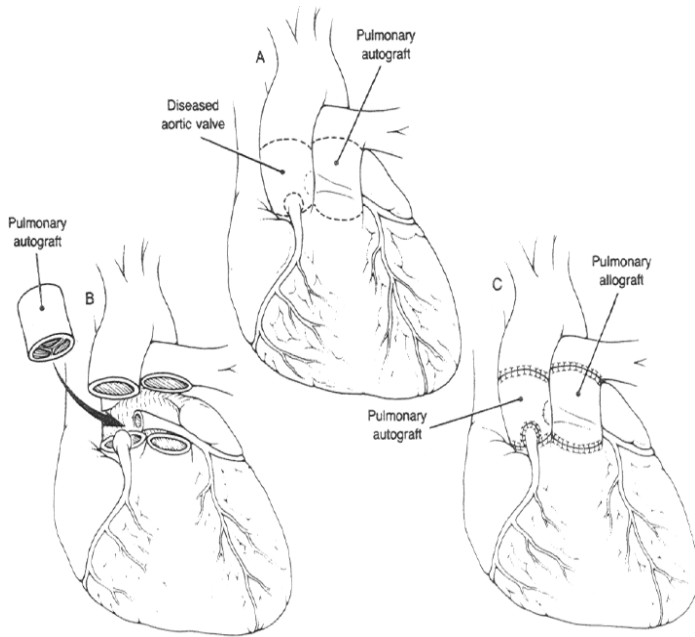

An ideal heart valve

- Non thromboembolism
- Chemical-biological inert*
- Low resistance
- Fast closing (<0,05sec)
- Good cooptation in closing position
- Stable physical – geometrical characteristics*
- Anatomic compatibility
- Permit stable strong suturing
- Non problems to receipt
- Easy – fast implantation (Harken D.E., 1962)

Mechanical valves - evolution

More than 30 different approaches from the first caged ball to recent trileaflet mechanical, including trileaflet polyurethane valves

Main design topics:

- Centrally weighed blood flow
- Hemocompatible biomaterials (to reduce anticoagulation therapy)
- Better fatigue strength
- Reduction of wear (cracks - cavitation)

Caged ball

- Early design (1961: Starr-Edwards)
- Silicone ball (+), Cage wire stellate, titanium
- Suturing ring Teflon, polypropylene
- Peripheral flow – shear stresses near vascular wall
- Big heavy moving ball – excess myocardial work – caged disc
- Big trans-valvular pressure gradient
- Strong anticoagulation therapy (life long)
- Noise, remodeling of vascular walls

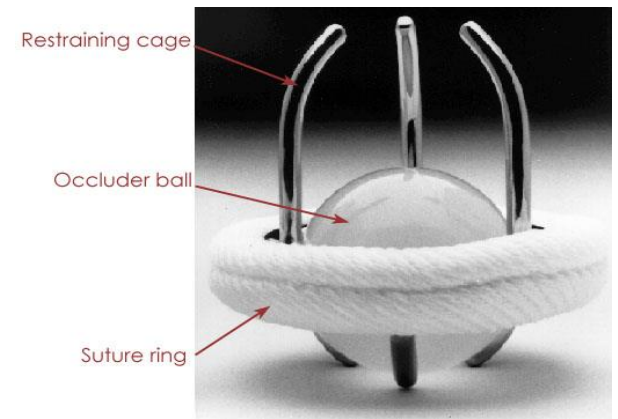
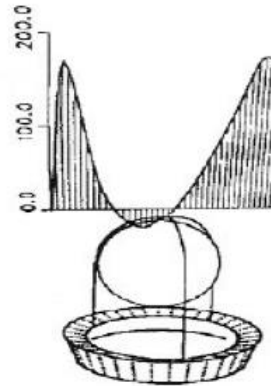

Tilting disc

- From mid 60s, after a short presence of caged disk
- Disk in angle under a stable supporting element
- Disk material: Pyrolytic carbon
- Support: Haynes 25, titanium
- Suturing ring: Teflon
- More physiological flow
- Fast movement, no backflow
- Less anticoagulation therapy (but still for lifelong)
- A risk for fatigue fracture to the soldering of outlet support wire (Bjork-Shiley 1979-90: 600 cases, 2/3 to death).
- Monobloc titanium case

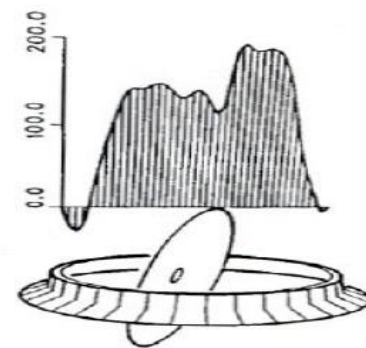
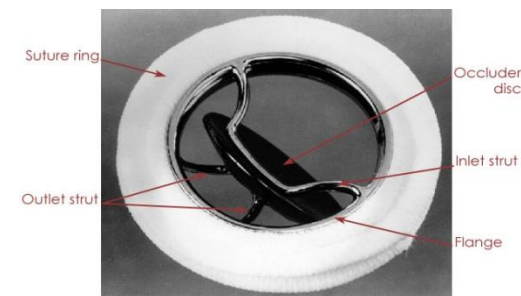
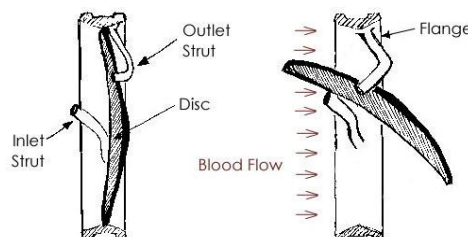

Bileaflet

- Presence in 1979
- Twin half disks, support by hinges
- Disks, ring coating by pyrolytic carbon
- Suturing ring: Teflon, polyester
- Better central flow
- Faster leaflet movement
- Problems of coaptation in closing
- Potential disk movement restrictions by tissue hypertrophy into hinges - ring

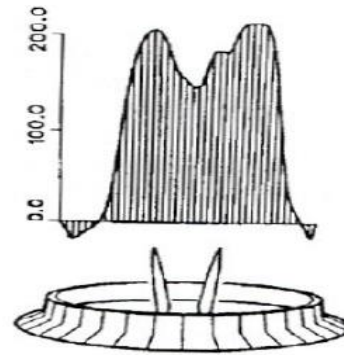

Trileaflet

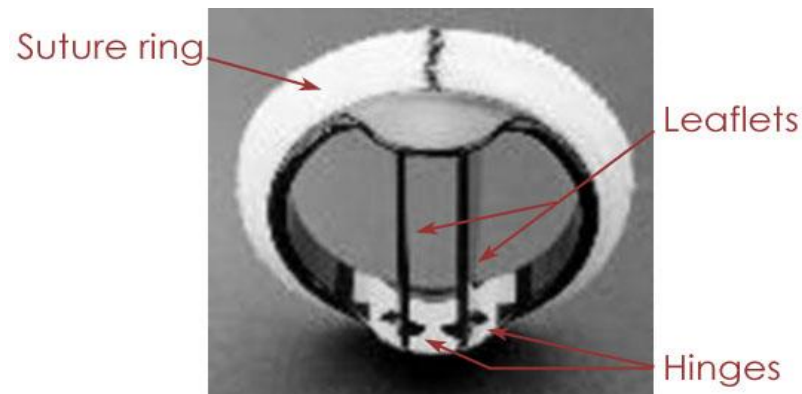
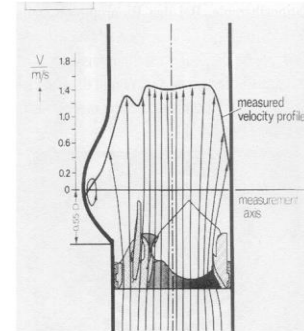
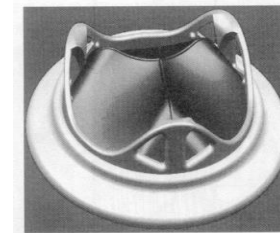

Natural geometry

Flexible leaflet valves

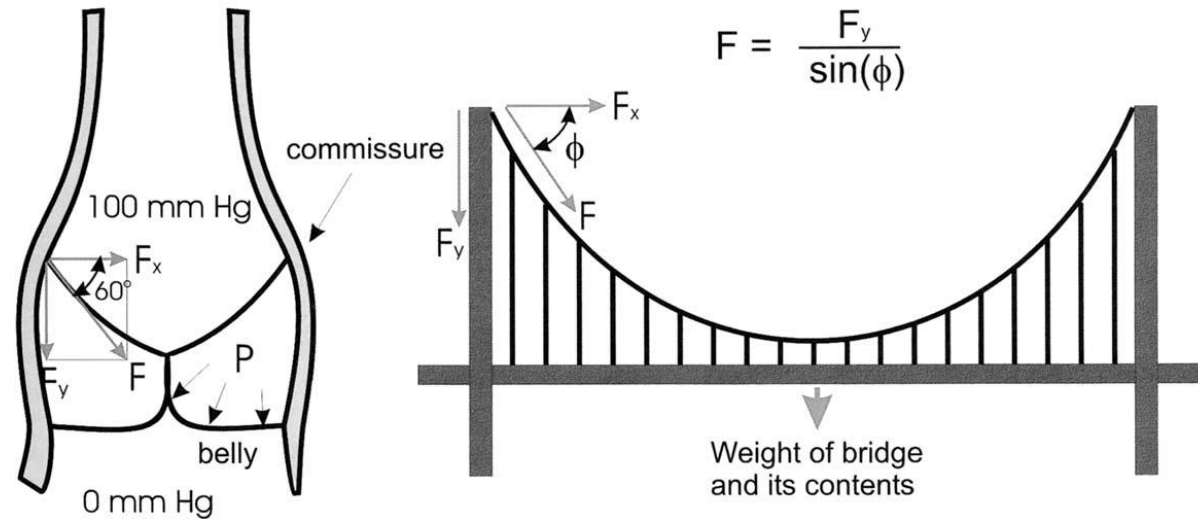

I. Vesely / Cardiovascular Pathology 12 (2003) 277–286

- Mechanical loading in systole – diastole
- Functional failure, fatigue
- Compatibility - calcification

Polymeric valves

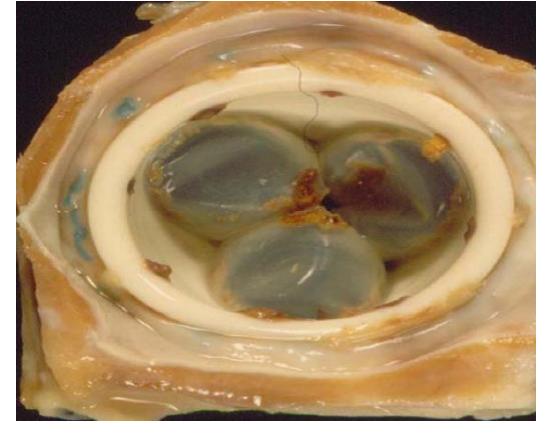
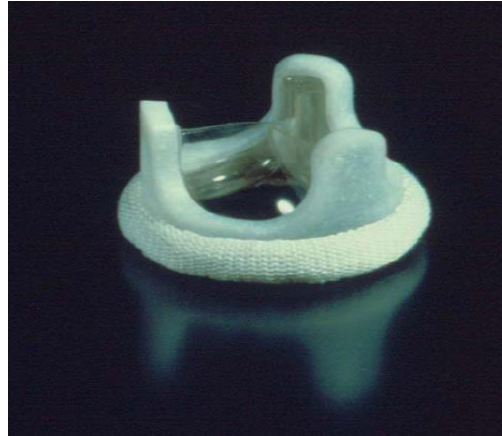
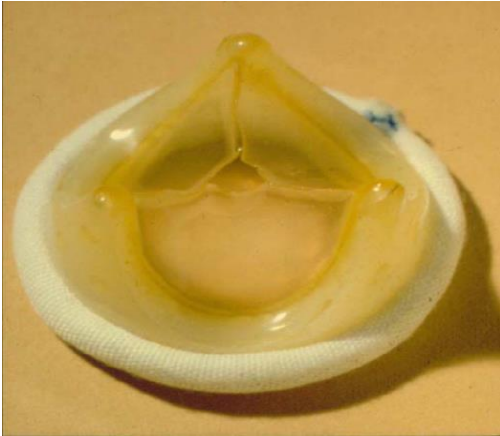

- Flexible elastomeric membranes (polyurethanes)
- Excellent hemodynamics
- Reduced functional strength
- Calcification
- Use in artificial heart devices

Biological valves

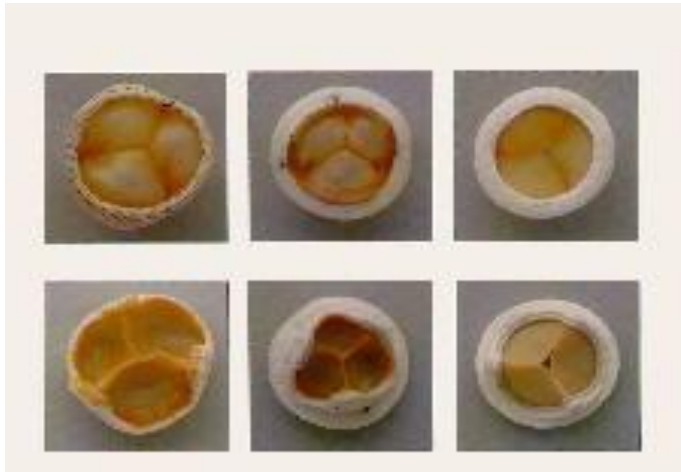

- Animal tissue (hole valve or constructed).
- Antigen neutralization (cell death -remove), crosslinking for proteolytic protection (Formaldehyde, glutaraldehyde)
- Excellent hemodynamics
- Reduced longevity
- Calcification
- Use in Elderly population, artificial heart devices

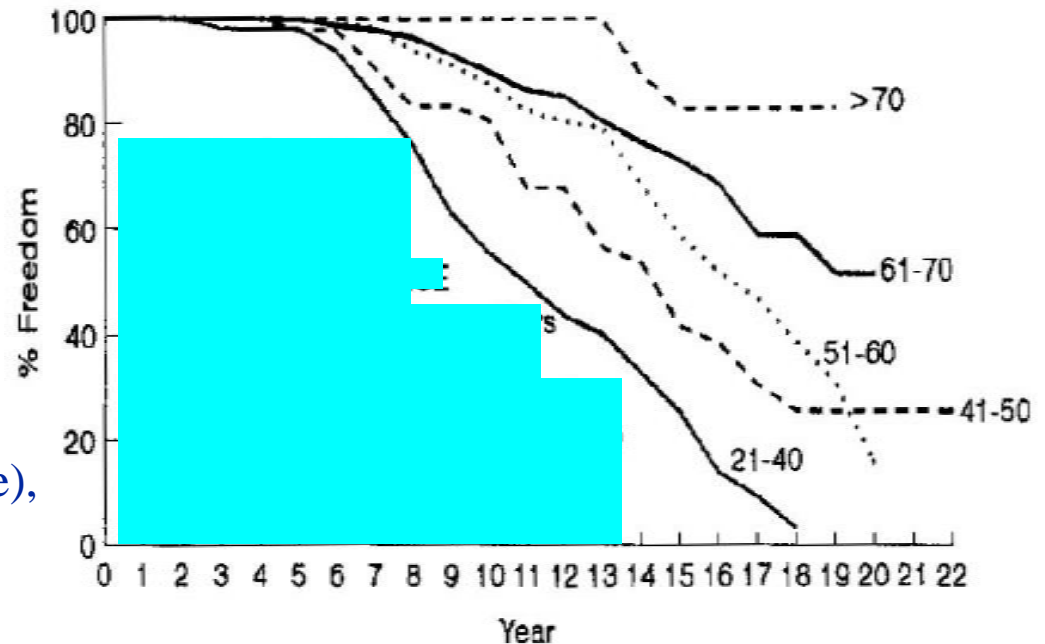

Carpentier-Edwards standard porcine aortic valves, aortic site

WRE Jamieson et al -Ann Thor Surg 1998

Types of biological valves

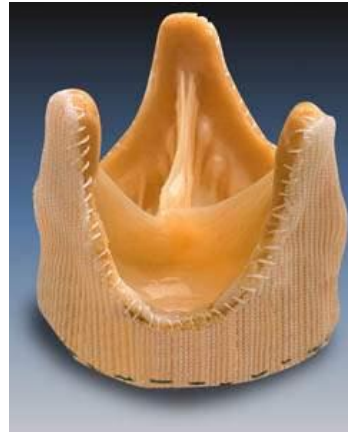
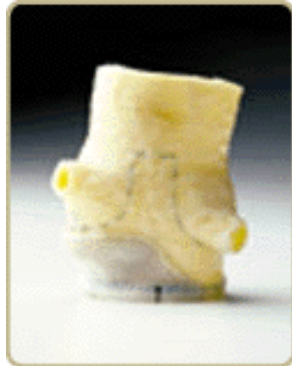
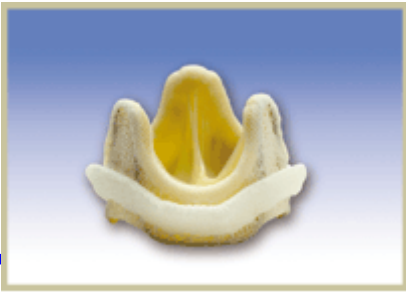

Isolation of aortic conduit from a porcine valve

Video

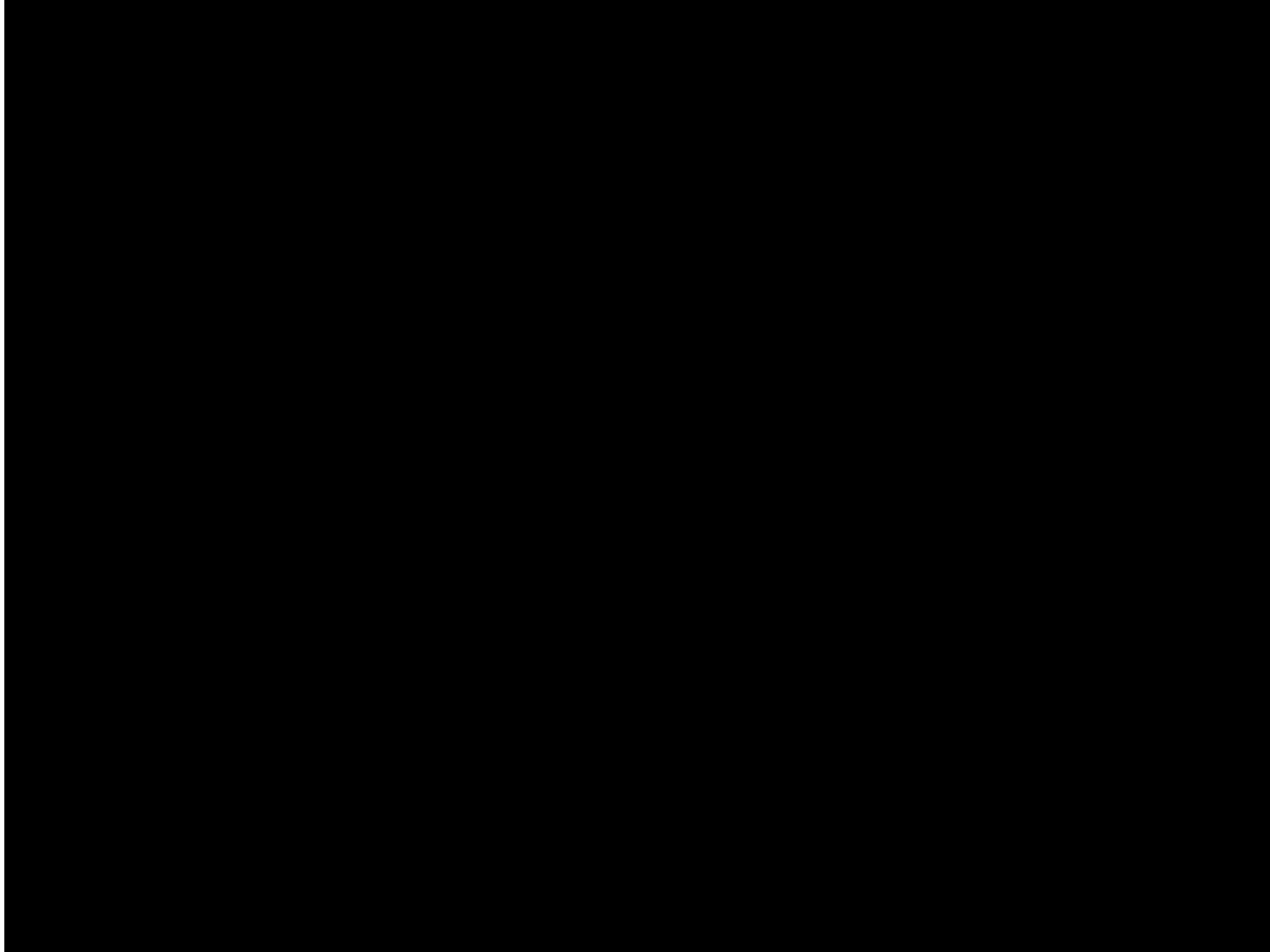

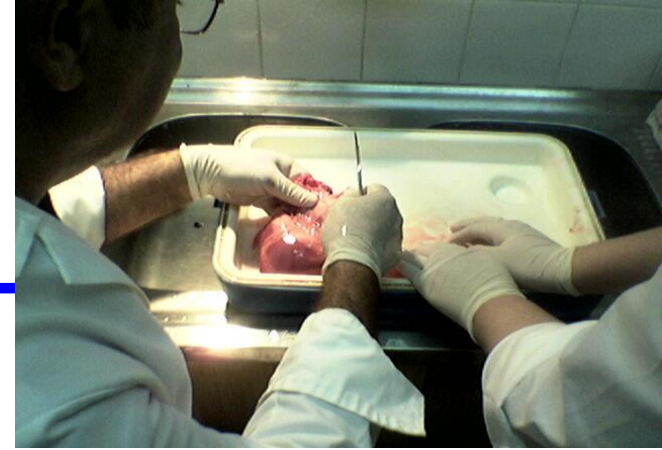

Photos

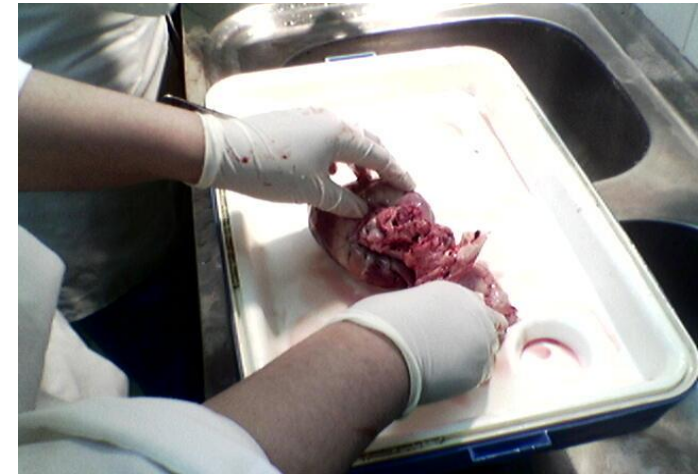

Fixation with glutaraldehyde



Evolution of bioprosthetic valves

- Glutaraldehyde crosslinking:
Apply pressure for valve leaflet closing
- High-low support profile
- From total porcine to structured pericardial valve
- Rigid-flexible supporting stent, stent less
- Postfixation anticalcification treatments

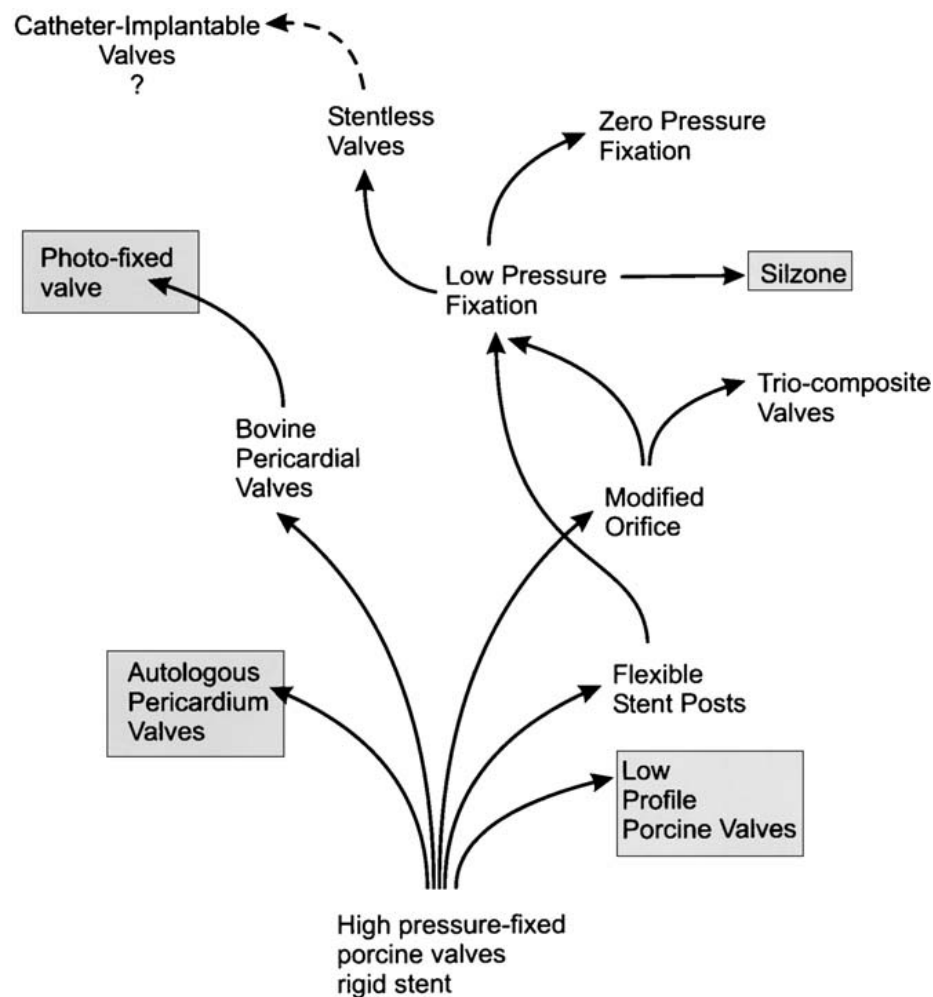

Calcification mechanisms, solutions

- Much is written, a few are proved
- Crystal nucleation Ca-PO_4 (+ sodium, magnesium, carbonates) in regions with high mass concentration-activation
- Necrotic cells, cell remnants – decellularization
- Phospholipids-alkaline phosphatase - hydrolysis , ethanol removing
- Failure of collagen fibers (fatigue, denaturation). Better fixation
- Lipids - removal
- Free aldehydes in treated-fixed tissue. Deactivation-masking

Proposed mechanisms

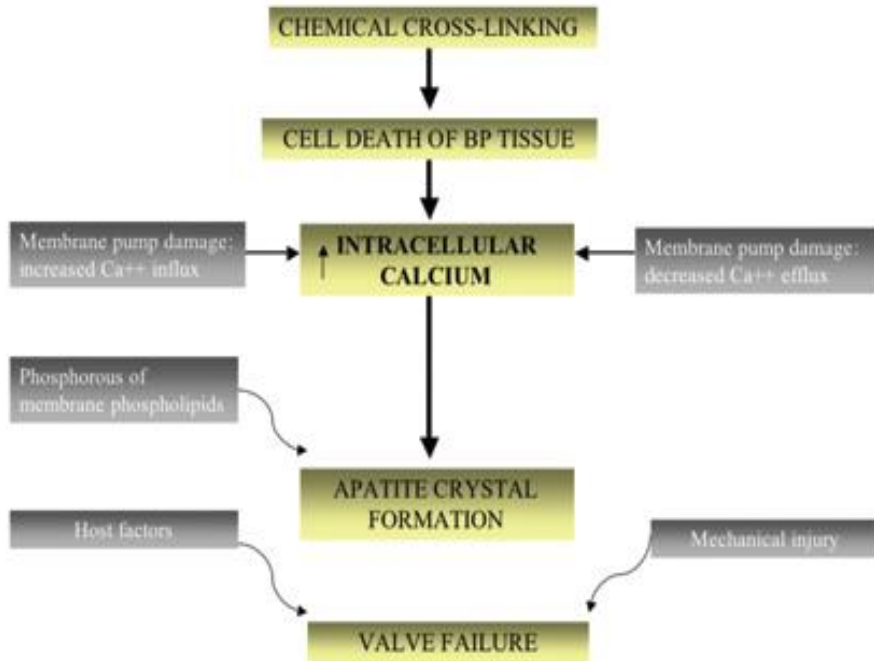

Thiene – Valente, 2004

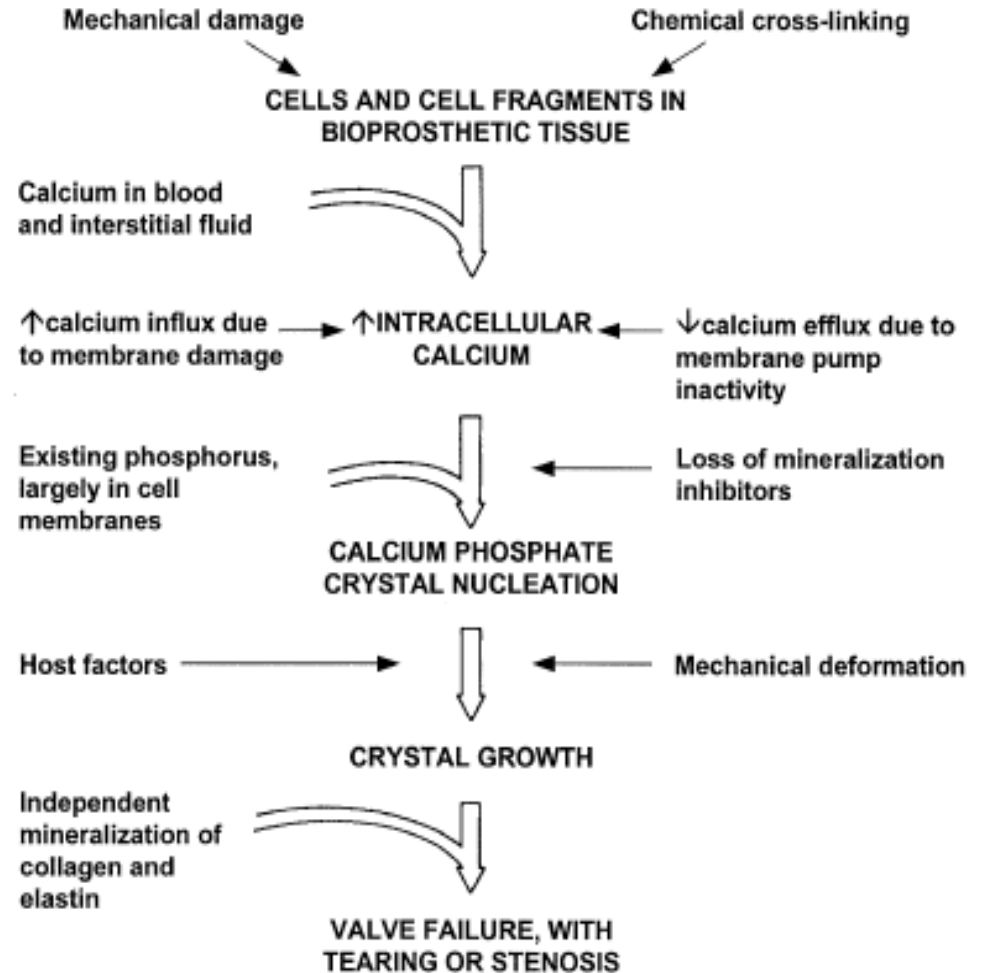

Schoen et Al., 2005

Pericardial bioprosthesis

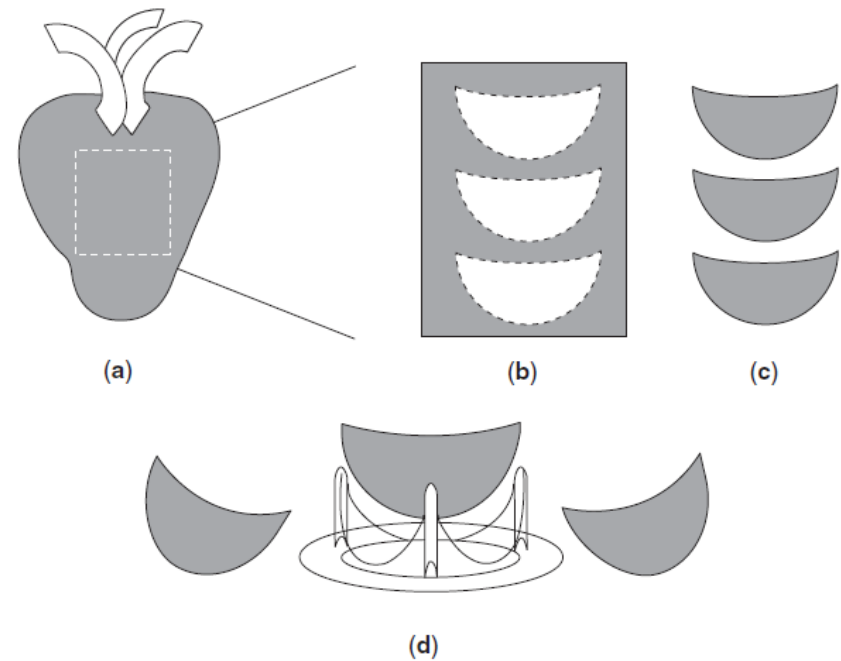
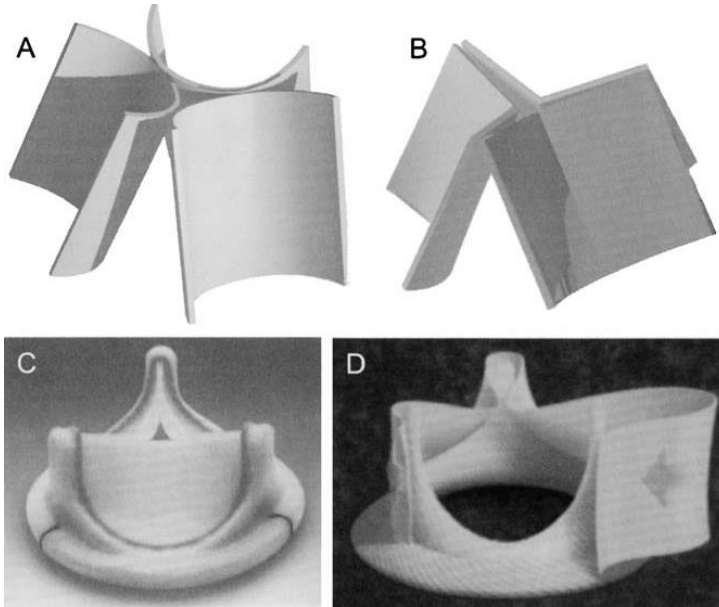

I. Vesely / Cardiovascular Pathology 12 (2003) 277–286

- Selection criteria - treatment
- Design – cut of leaflet
- Leaflet suturing on stents: Continuous-separate

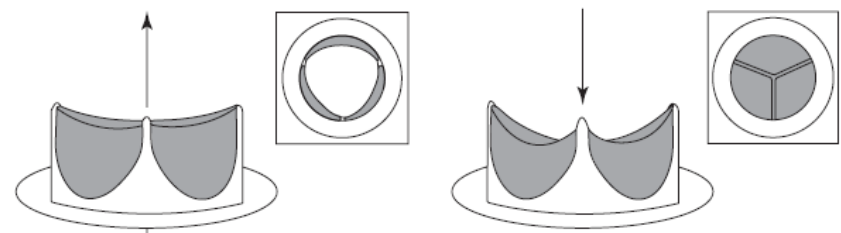

DAN T. SIMIONESCU

Wiley Encyclopedia of Biomedical Engineering, Copyright © 2006

Stent less porcine valves

- Optimization on leaflet flexibility
- Gain in dimensions
- Changes for better hemodynamics

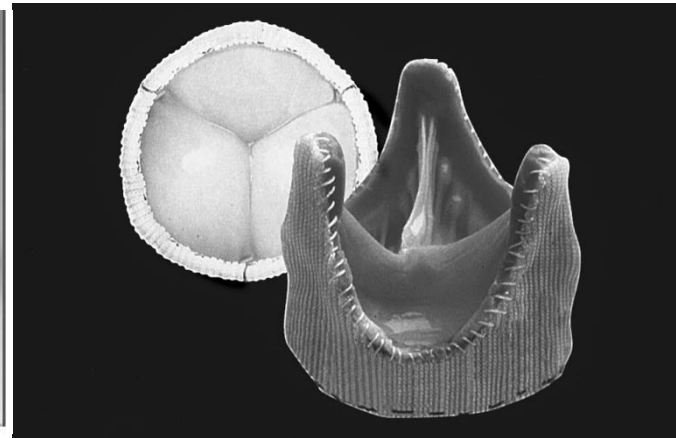
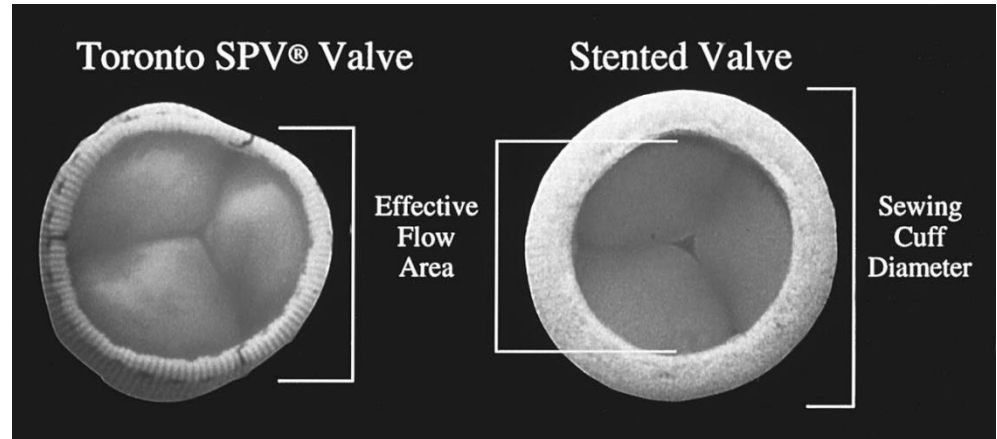

Dan Simionescu,

Wiley Encyclopedia of Biomedical Engineering, Copyright © 2006

Opin Cardiol 2000, 15:74–81 © 2000

Regenerative valves

Tissue engineered scaffolds

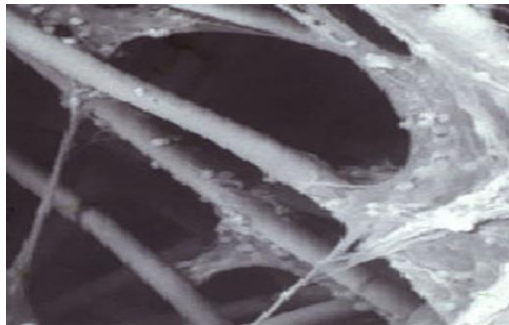
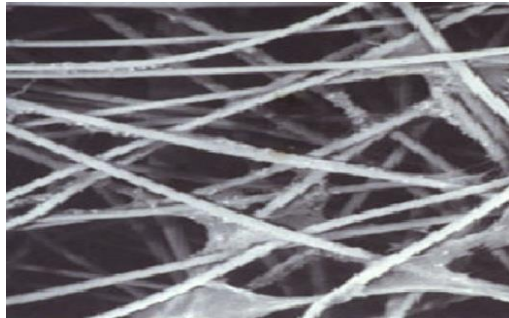

Important factors

- Mechanical performance
- Cell proliferation/spreading
- Changes in cell phenotypes
- Extracellular matrix (tissue) production from cell
- Vascularization
- Biodegradation of scaffolds
- Regeneration/growth

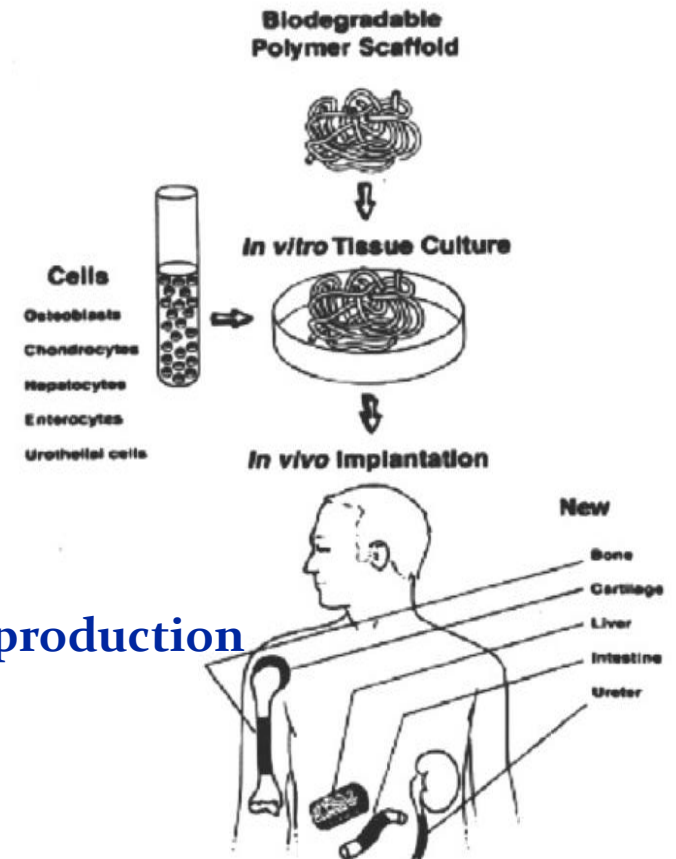

Tissue engineered heart valves I

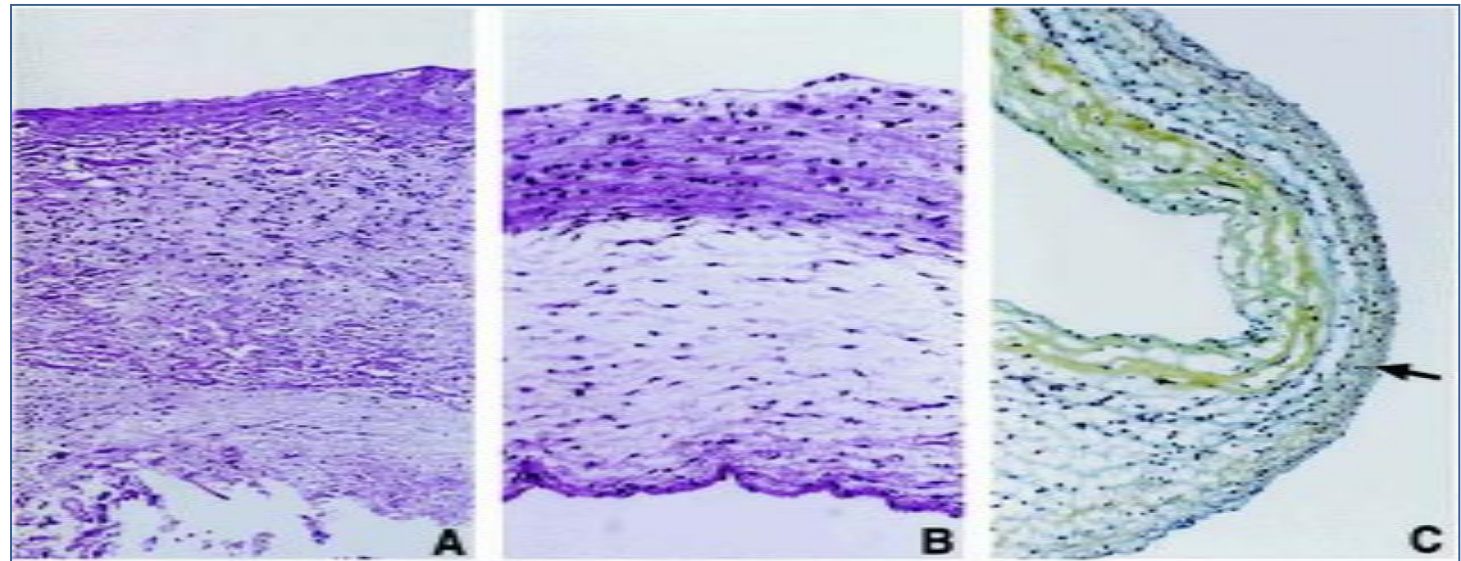

Weeks *in vivo* A=6, B=16, C=20

Scaffold: PGA, prime cells from vascular wall

Sheep implantation

In vitro: 21 days

SP Hoerstrup et al -CIRCULATION, 20006

Bioreactor (2 step procedure)



Mechanical heart valves

Design characteristics

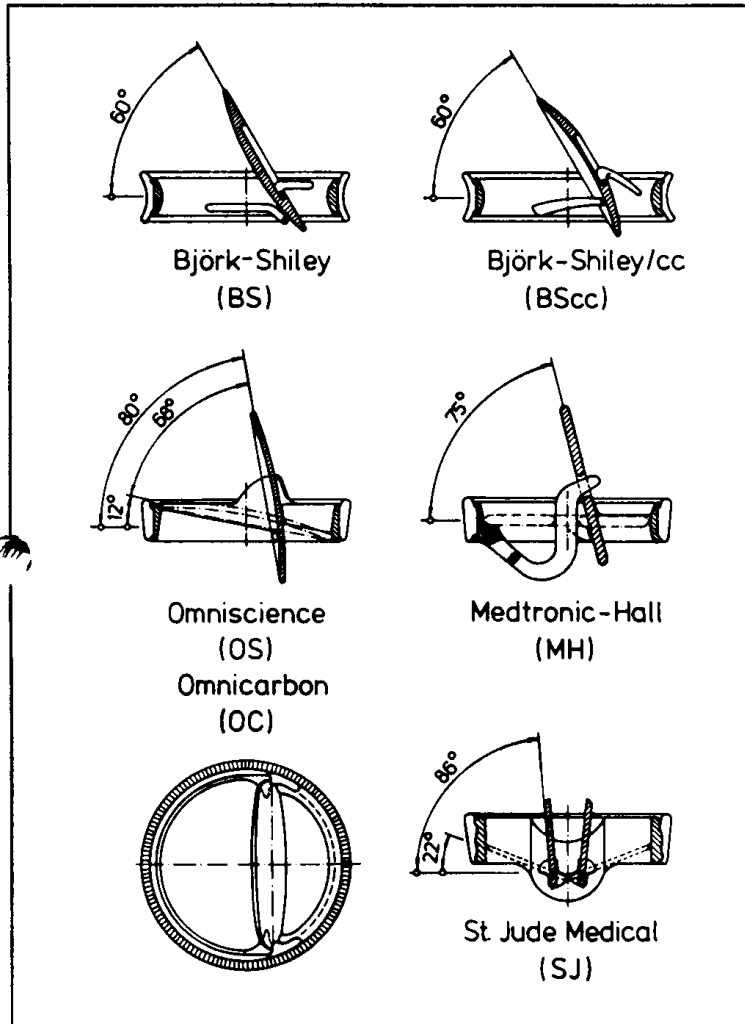

Fig. 1 - Technical (mechanical) heart valve prostheses.

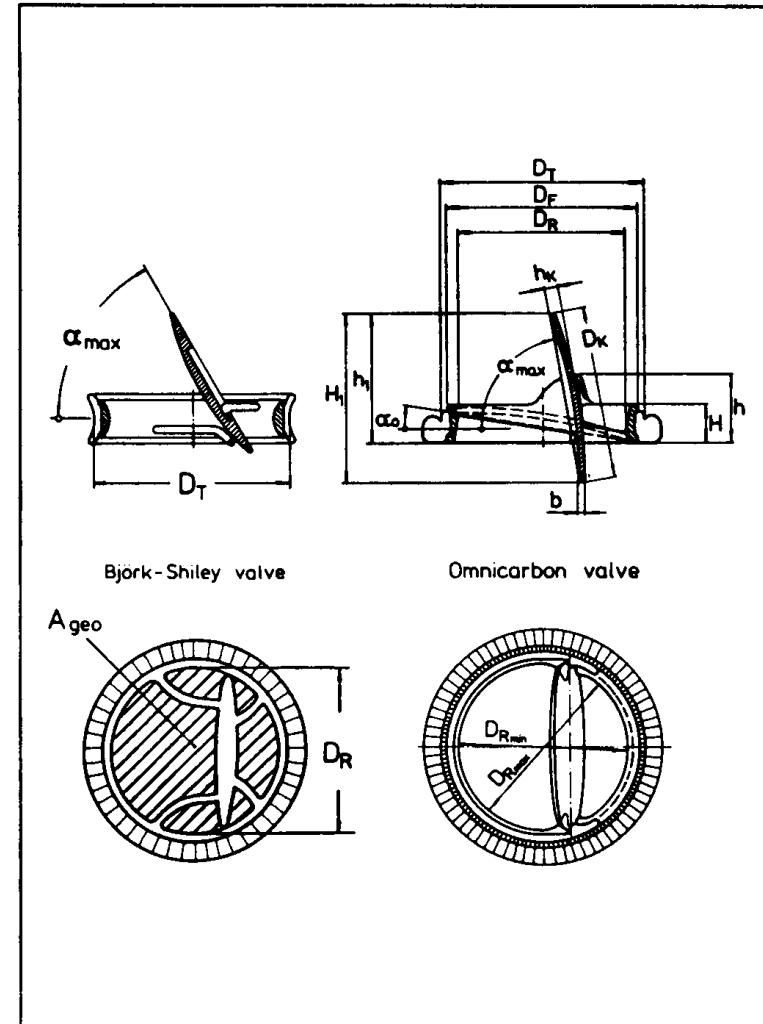
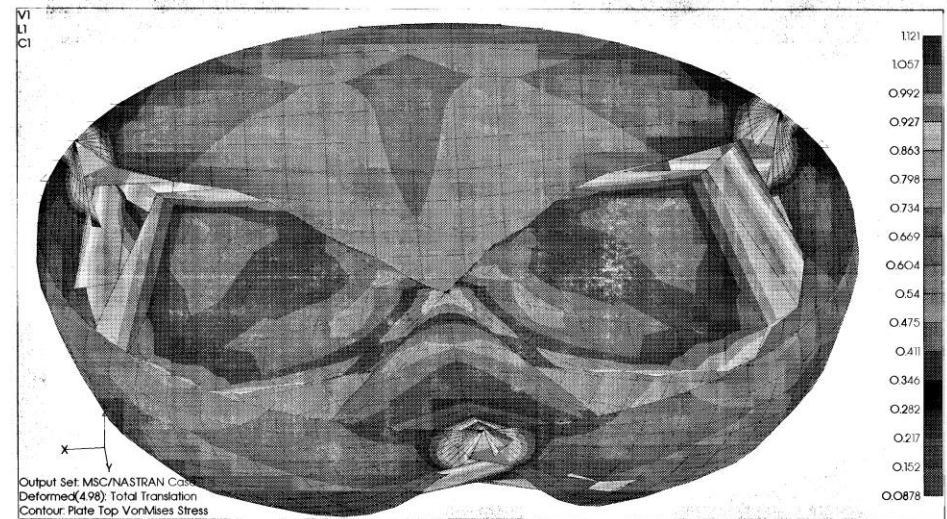
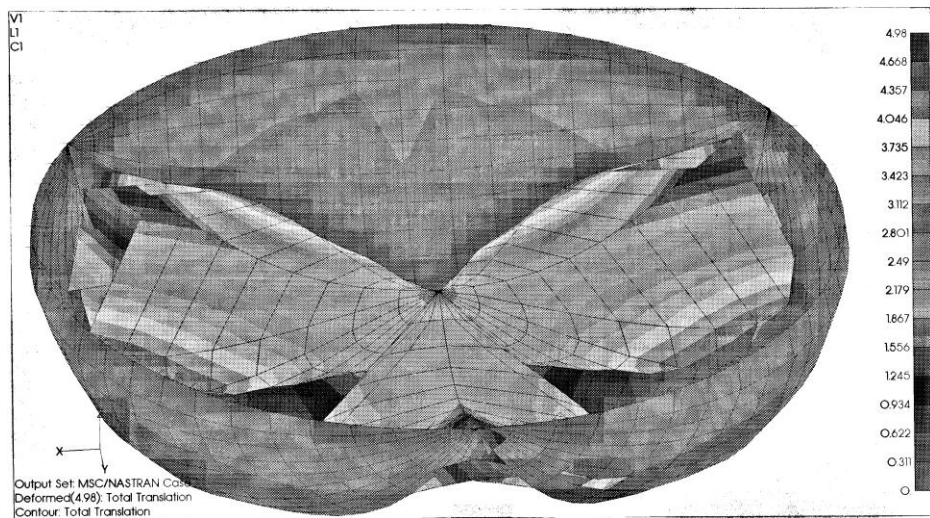
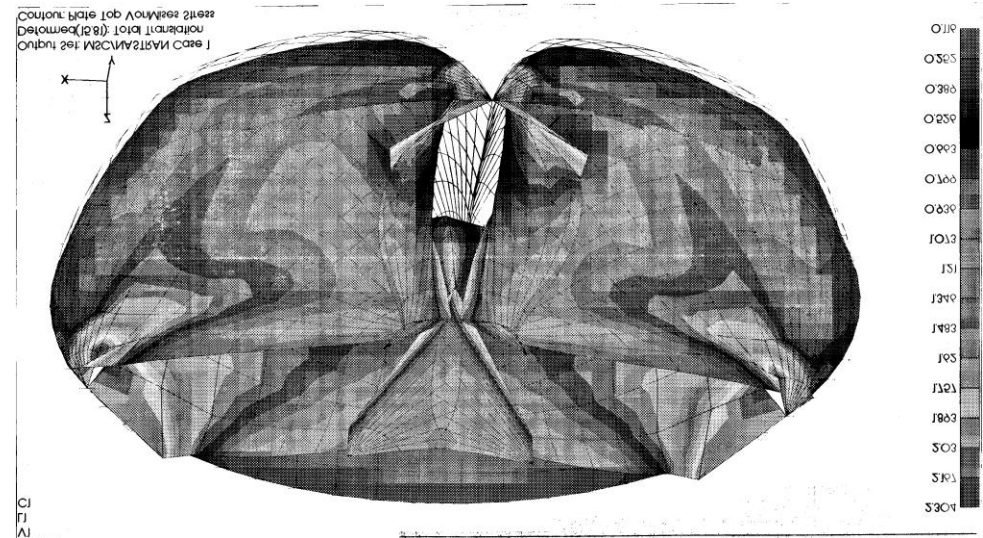
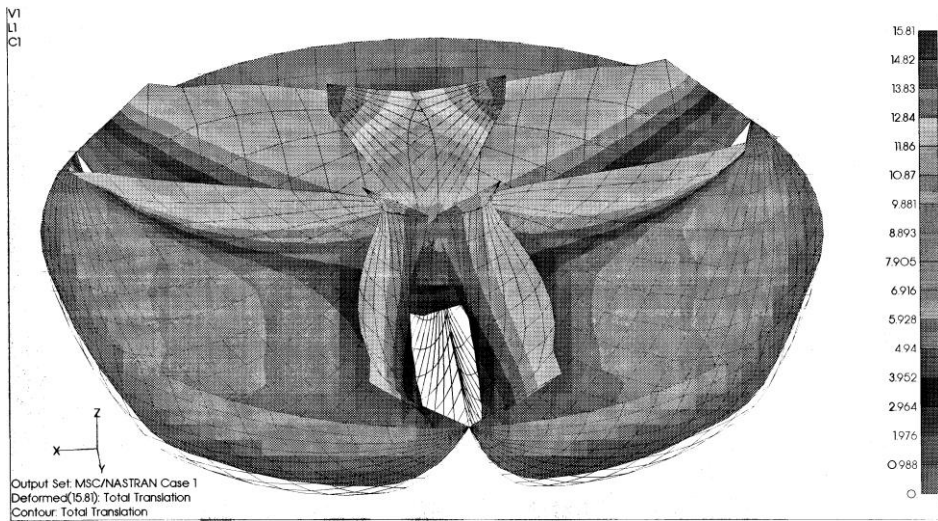

Fig. 2 - Geometrical parameters of technical heart valve prostheses.

Modelling finite elements

S. Antoniadis, D. Mavrilas



Design of a polymeric valve

G. Gacciola *et al.*

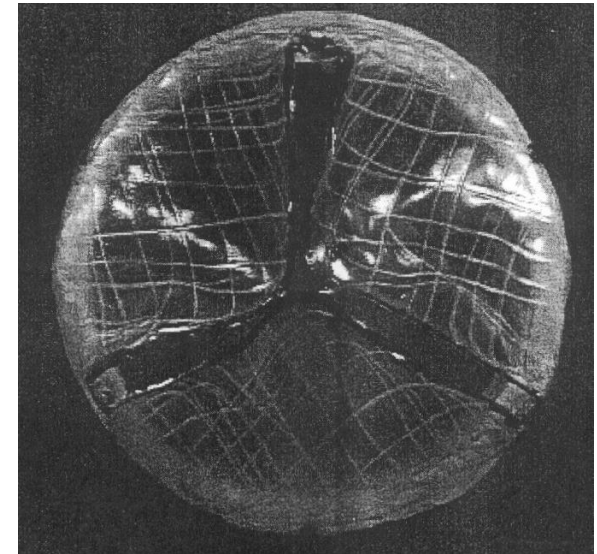
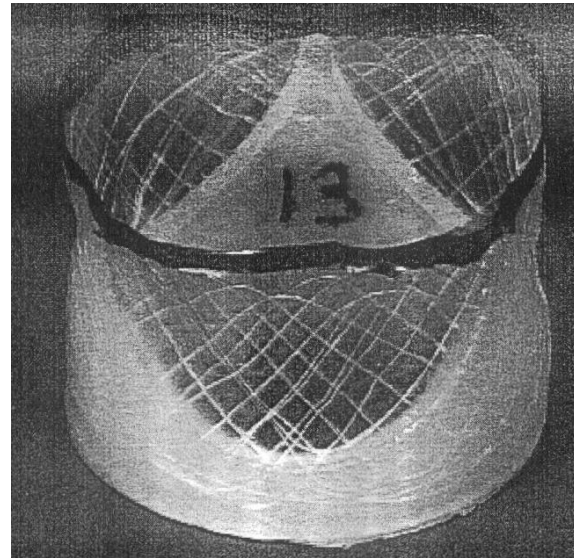
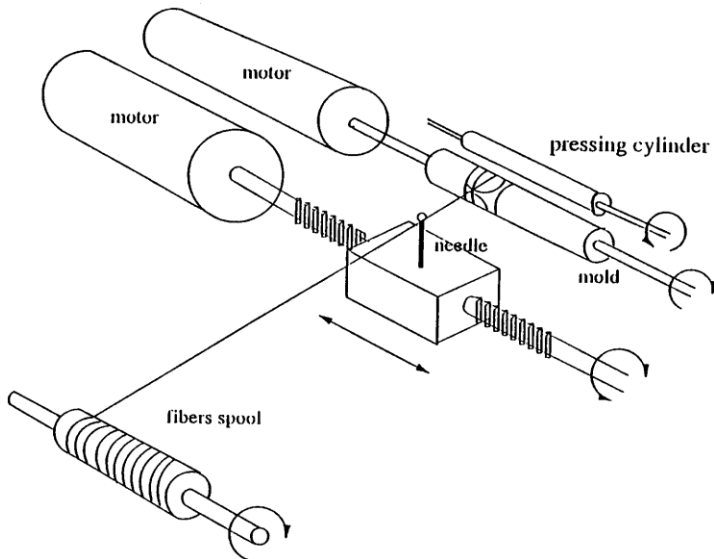
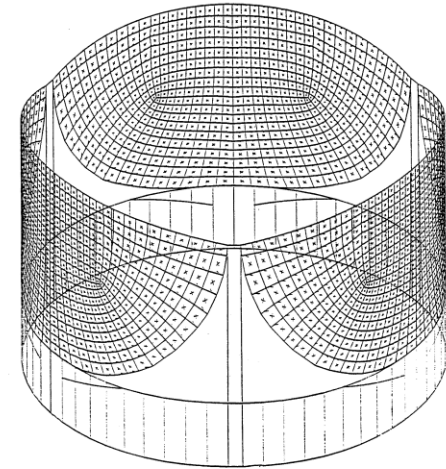
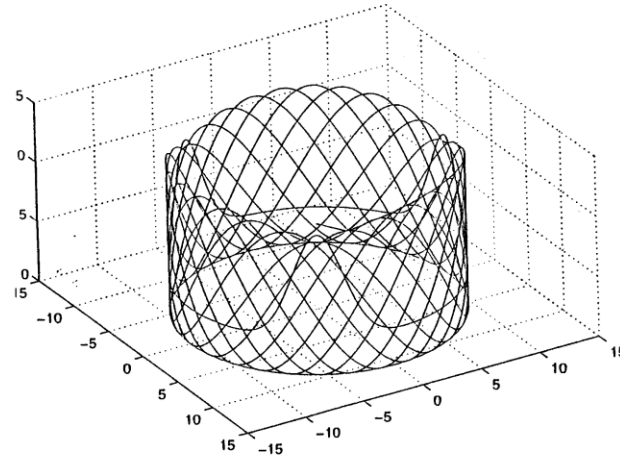
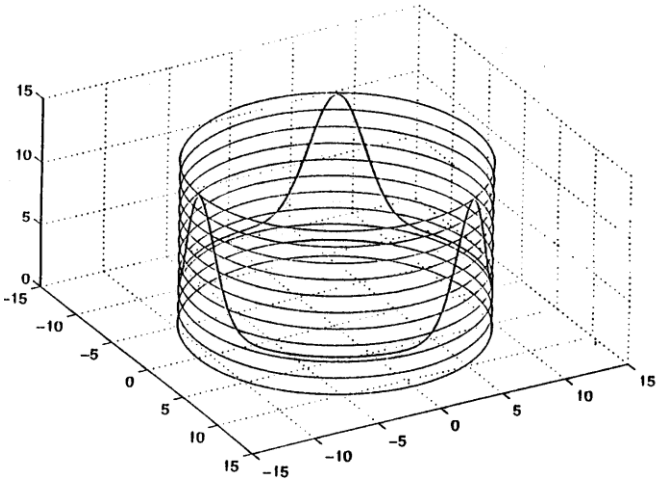

Design of artificial valves

Standardization of testing

CEN European Committee for Standardization
Comité Européen de Normalisation
Europäisches Komitee für Normung

Ser. n. Netherlands NL 654 820 NL 654 820 NL 654 820 Netherlands telephone: + 31 15 690 390 telefax: + 31 15 690 190 telex: 38144 nni nl telegrams: Normalisatie Delft	doc. nr. CEN/TC285 WG3 TF1 item nr. supersedes document CEN/TC285 WG3 TF1 Title: Cardiac Valves
---	--

English version

"Non active surgical implants
Particular requirements for cardiac and vascular implants
Part 1: cardiac valves - March 1994

INTERNATIONAL STANDARD

ISO 5840

Second edition
1989-12-01

Cardiovascular implants — Cardiac valve prostheses

Implants cardiovasculaires — Prothèses valvulaires



CAGED BALL



CAGED DISK

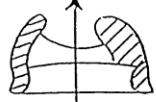

TISSUE

DRAFT
Replacement Heart Valve Guidance

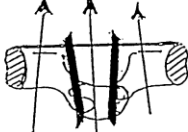

BILEAFLET

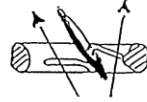

TILTING DISK

Division of
Cardiovascular,
Respiratory, and
Neurological
Devices
October 14, 1994

U.S. DEPARTMENT OF HEALTH AND HUMAN SERVICES
Public Health Service
Food and Drug Administration
Center for Devices and Radiological Health

European standardization



ELSEVIER

European Journal of Cardio-thoracic Surgery 32 (2007) 690–695

EUROPEAN JOURNAL OF
CARDIO-THORACIC
SURGERY

www.elsevier.com/locate/ejcts

Update of the European standards for inactive surgical implants in the area of heart valve prostheses

Walter Eichinger^{a,*}, Sabine Däbritz^b, Rüdiger Lange^a

^a *Clinic for Thoracic and Cardiovascular Surgery, German Heart Center Munich, Lazarettstrasse 36, D-80636 Munich, Germany*

^b *Department of Cardiac Surgery, University Hospital Grosshadern, Marchioninistrasse 15, D-81377 Munich, Germany*

Received 11 April 2007; received in revised form 10 August 2007; accepted 15 August 2007; Available online 17 September 2007

Abstract

Objective: The approval of a heart valve for the European market takes place in accordance with European and international standards. A new version of the EN Standards was published in June 2006, which responded to different technical innovations in the area of heart valve technology. This work outlines the differences between the new EN ISO 5840 (2005) and the old EN 12006-1 (1999). **Methods:** We compared the 'new' EN ISO 5840 (2005) and the 'old' EN 12006-1 (1999). **Results:** The following aspects have been updated in the new EN ISO 5840:

- Size designation of biological and mechanical heart valve prostheses in accordance with the patient annulus
- Differentiation of the annular implantation position (intra-annular, intra-supra-annular, supra-annular)
- Table for the description of the components of a heart valve prosthesis
- Use of compliance chambers for the hydrodynamic testing of prostheses without scaffold
- Determination of the minimum requirement for heart valve prostheses in hydrodynamic tests and specification of reference values with regard to prosthesis-related complications in clinical studies
- Definition of the requirements for clinical long-term studies (patient number, length)
- Introduction of an obligatory post-observation timeframe of 5 years for mechanical heart valves and of 10 years for biological heart valves.

Conclusions: The update in the new EN ISO 5840 gives consideration to the technologic evolution of heart valve development. Several changes in the new standard will improve safety for the patient and ensure high quality in the field of heart valve technology.

© 2007 European Association for Cardio-Thoracic Surgery. Published by Elsevier B.V. All rights reserved.

Standardization

Criteria for valves-results

Table 3
Minimum performance requirements (ISO 5840) [1]

Position	Aortic								Mitral			
	19	21	23	25	27	29	31	25	27	29	31	
Size												
EOA (cm ²)	0.70	0.85	1.00	1.20	1.40	1.60	1.80	1.20	1.40	1.60	1.80	
Regurgitant fraction (%)	10	10	10	15	15	20	20	15	15	20	20	

EOA, effective orifice area (effective opening area of the prosthesis).

Table 6
Reference values of 1-year data (incidence in %)

	Aortic valve (flexible)	Aortic valve (rigid)	Mitral valve (flexible)	Mitral valve (rigid)
Structural valve deterioration	0.03	0.00	0.12	0.00
Thromboembolism (major, RIND)	2.06	2.78	2.48	2.63
Valve thrombosis	0.10	0.00	0.19	0.61
Anticoagulant hemorrhage	0.45	2.44	0.80	1.95
Prosthetic valve endocarditis	0.59	0.93	0.68	0.54
Non-structural valve dysfunction/paravalvular leak	0.38	0.84	1.05	1.75
Reoperation	0.77	1.09	1.05	1.95

Testing of valve function

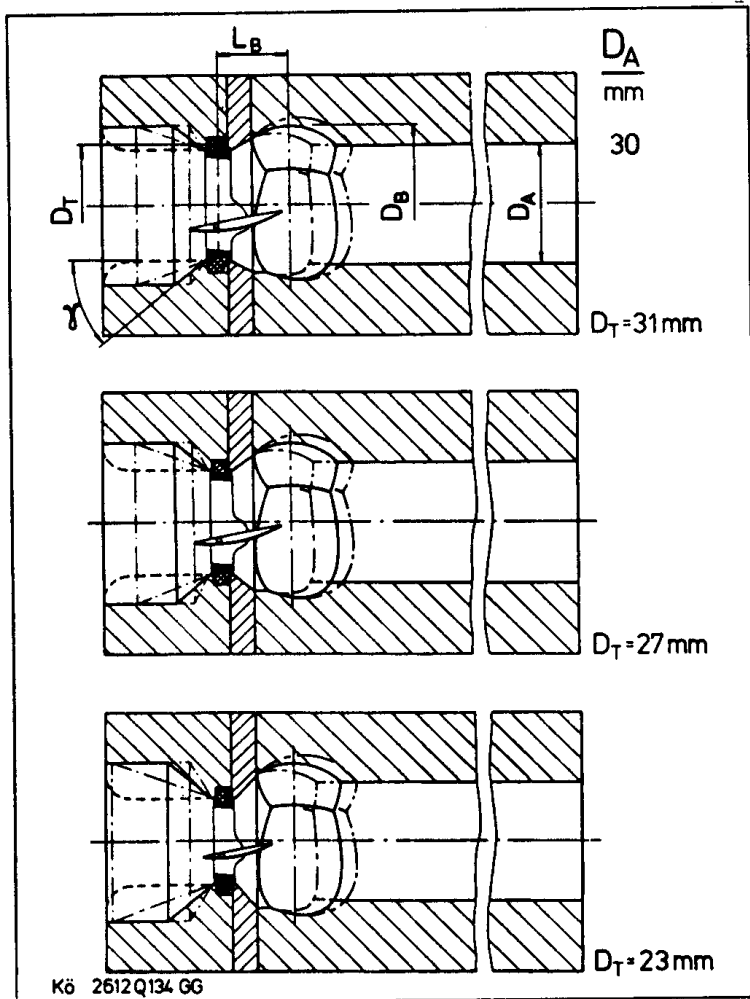

Fig. 3 - Geometry of standardized aortic models.

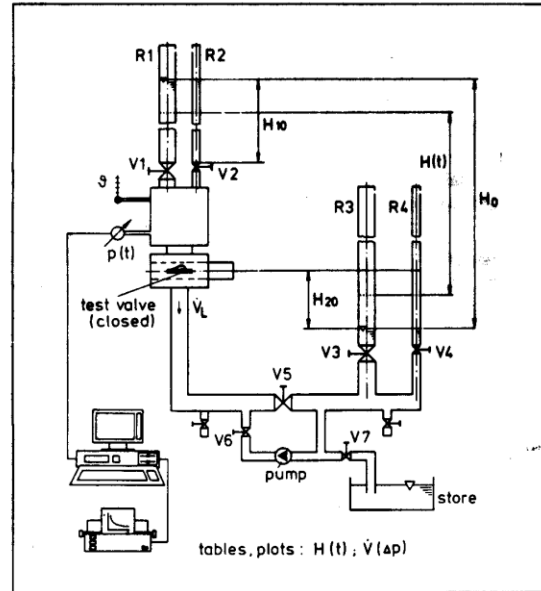

Fig. 6 - Leakage quick tester for quasi-steady flow.

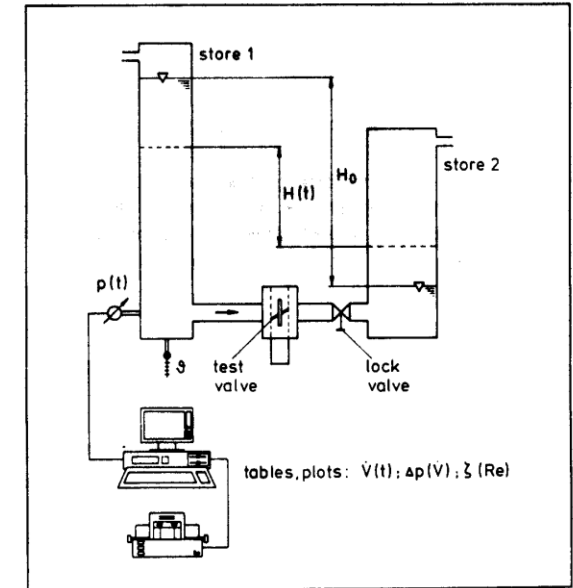

Fig. 7 - Pressure loss quick tester for quasi-steady flow.

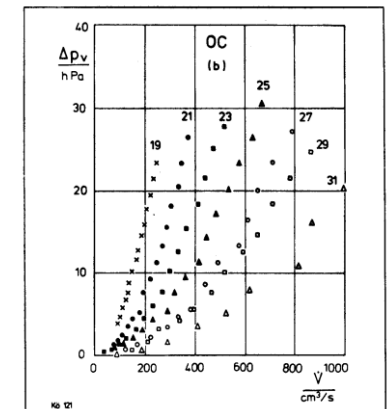
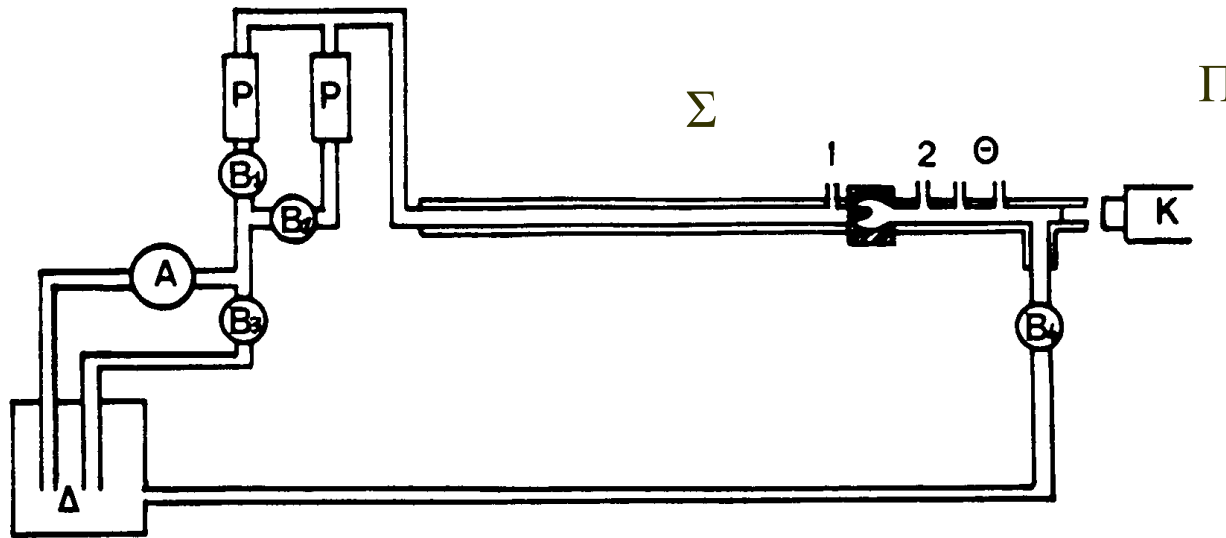
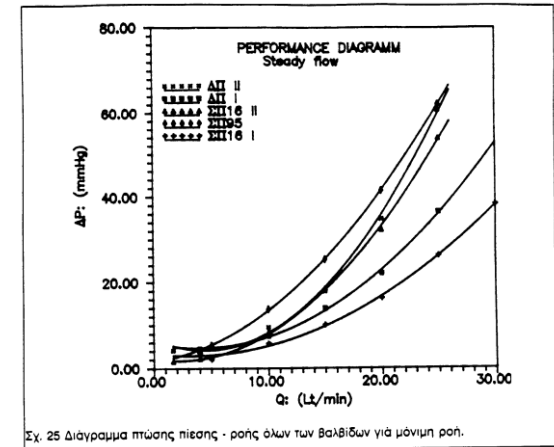

Fig. 8 - Pressure loss of a series of the Omnicarbon Valve depending on the volume flow measured in the pressure loss quick tester.

Testing of valve function. Steady flow



Transvalvular
pressure gradient
 $DP \approx KQ^2/(EOA)^2$



Σχ. 23 Παραστατικό διάγραμμα της πειραματικής διάταξης μόνιμης ροής. (A) Φυγοκεντρική αντλία, (B₁), (B₂), (B₃) και (B₄) βάνες ρύθμισης της ροής, (P₁) και (P₂) ροόμετρα, (Σ) σωλήνας εισόδου, (Θ) αορτικός θάλαμος, (1) και (2) στόμια μέτρησης της πίεσης, (Π) οπτικό παράθυρο, (Κ) βιντεοκάμερα και (Δ) δεξαμενή τροφοδοσίας.

From
D. Mavrilas, PhD Thesis, 1991

Testing of valve function. Pulsatile flow

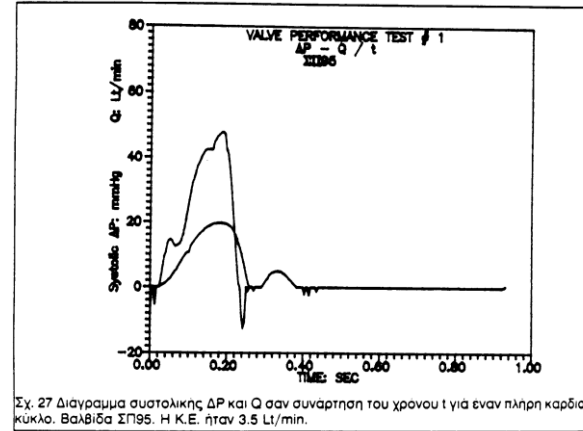
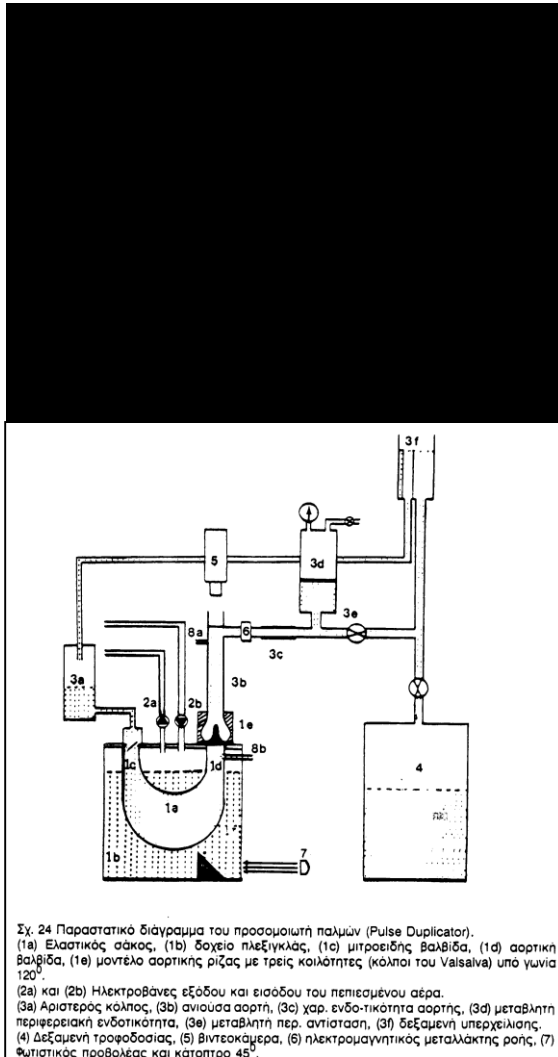

Transvalvular pressure gradient
 $DP \approx KQ^2/2(EOA)^2$

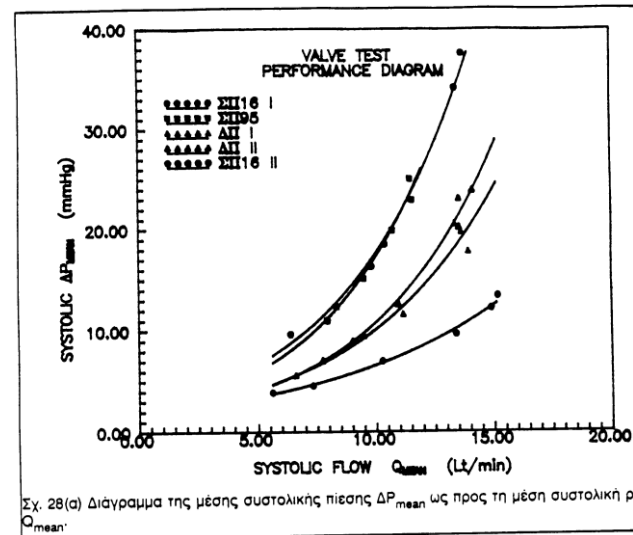

Effective Orifice Area
 $EOA \propto Q_{rms}/D_{mean}^{1/2}$

From
 D. Mavrilas, PhD Thesis, 1991