

## LOSS OF EXCITATION PROTECTION FOR MODERN SYNCHRONOUS GENERATORS

John Berdy  
General Electric Company  
Schenectady, New York

**ABSTRACT**

This paper presents the results of a study into the application and performance of the offset mho distance relay for the loss of excitation protection of synchronous generators. Included is information on the loss of excitation characteristics of modern generators, on relay performance during transient swings and low frequency disturbances and on generator protection.

**INTRODUCTION**

In 1949,<sup>1</sup> a single phase offset mho relay was introduced for the high speed detection of loss of excitation in synchronous generators. This distance relay approach was developed to provide improved selectivity between loss of excitation and other normal or abnormal operating conditions and to provide the operating times necessary for optimum protection of both the generator and the system.

Over the years, the offset mho relay has been widely accepted for loss of excitation protection and experience with the relay has been excellent. The relay has demonstrated its capability of detecting a variety of excitation system failures and to discriminate between such failures and other operating conditions. The relatively few cases of incorrect operation that have occurred can be attributed to incorrect relay connections (major cause), and blown potential transformer fuses.

In spite of this excellent experience, there has been some user apprehension about the performance of distance type of relaying for loss of excitation protection. In particular, there has been concern over possible incorrect operation of the relay when operating the generator in the underexcited region, during stable transient swings and during major system disturbances that cause underfrequency conditions.

In view of this continuing concern over relay performance and in view of the fact that machine parameters have changed appreciably during the past twenty years, a general study was initiated to review the application and the performance of the offset mho loss of excitation relay for a variety of system conditions. This paper discusses the results of this study and provides guidance on the application of loss of excitation protection.

**REVIEW OF RELAY CHARACTERISTICS AND SETTINGS**

The offset mho loss of excitation relay is a single phase, single element distance relay which is applied to the generator terminals and connected and set to look into the machine. On the R-X diagram (see Fig. 1) the relay characteristic is an offset circle which has an angle of maximum torque that falls on the (-X) ordinate. As viewed from the machine terminals the relay will operate for any impedance phasor that terminates inside the circular characteristic.

When the relay was introduced in 1949, it was recommended the offset be set equal to one-half of the direct axis transient reac-

tance ( $X'_d/2$ ) and the diameter of the circle set equal to the direct axis synchronous reactance ( $X_d$ ). It was shown<sup>1</sup> that with the machine reactances that existed at that time, these settings would detect a loss of excitation from any machine loading and that there would be optimum selectivity against operation during stable power swings. Machine direct axis synchronous reactances were in the range of 1.1 to 1.2 per unit.

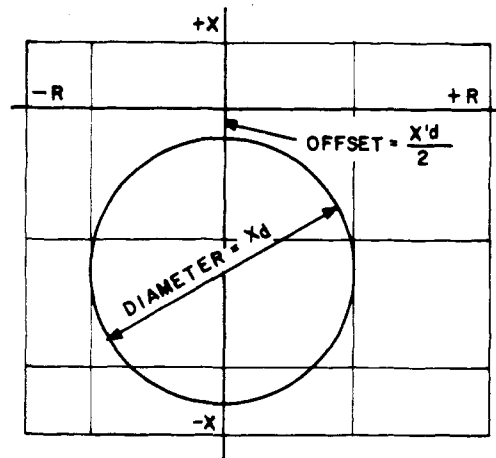

Fig. 1. Operating Characteristic of Loss of Excitation Relay.

In more recent machine designs, these synchronous reactances have increased to a 1.5 to 2.0 per unit range. With the advent of these higher impedance machines there has been reluctance by some utilities to use relay settings proportional to synchronous reactance, mainly because of a fear that the resulting large circle diameters might infringe on the underexcited operating capability of the machine. Therefore where this possibility was a concern, it has been recommended that the relay reach be limited to an assumed synchronous reactance of 1.0 per unit. When this recommendation was made it was recognized that this reduced setting would detect a loss of excitation with high machine loadings (the most severe condition for both the machine and the system) but would not provide coverage if the machine was lightly loaded. While this limited coverage was acceptable to the concerned user, there has been some question as to the extent of protection being provided. Therefore, one of the purposes of the study was to determine quantitatively the protective limits of a reduced setting.

**GENERATOR LOSS OF EXCITATION CHARACTERISTICS**

This section presents and discusses in some depth the loss of excitation characteristics of modern tandem and cross compound generators. As noted in reference 1, the loss of excitation characteristic refers to the locus of the apparent impedances as viewed from the generator terminals during a loss of excitation condition. These characteristics were determined for typical machine designs in a digital computer study using a comprehensive dynamic model<sup>2</sup> of a turbine generator.

The following discussion will consider the effect of initial generator loading and system impedance on the impedance locus, on the generator terminal voltage and on machine loading during a loss of excitation condition. The discussion will also consider the effect of voltage regulators on cross compound generators. In all cases the loss of excitation characteristics will be plotted with respect to two relay settings: one setting will have a circle diameter of 1.0 per unit, the other will have a circle diameter equal to machine synchronous reactance. The offset, in both cases, will be equal to  $X'_d/2$ .

Paper T 73 316-7, recommended and approved by the IEEE Power System Relaying Committee of the IEEE Power Engineering Society for presentation at the IEEE PES Summer Meeting & EHV/UHV Conference, Vancouver, Can., July 15-20, 1973. Manuscript submitted August 28, 1972; made available for printing April 17, 1973.

In all cases, it was assumed the loss of excitation was caused by a short-circuited field, the most probable mode of failure. For the less likely case of an open field, the loss of excitation characteristics will differ to some extent from those presented here but the final impedances as viewed from the generator terminal will be essentially the same as for a short-circuited field.

While the discussion will be limited to steam machines with specific parameters, the results and phenomena described also apply to hydro-generators and machines with other parameters.

As a point of interest, it should be noted that the loss of excitation characteristics and phenomena presented here do not differ appreciably from those reported by Concordia,<sup>3</sup> Temoshok and Mason some twenty years ago.

#### Loss of Excitation - Tandem Compound Generators

Figure 2 shows the loss of excitation characteristics for a typical large tandem compound generator that is connected to a system through a step-up transformer having a .15 per unit impedance on the machine base. These characteristics are shown as a function of both initial machine loading and system impedance.

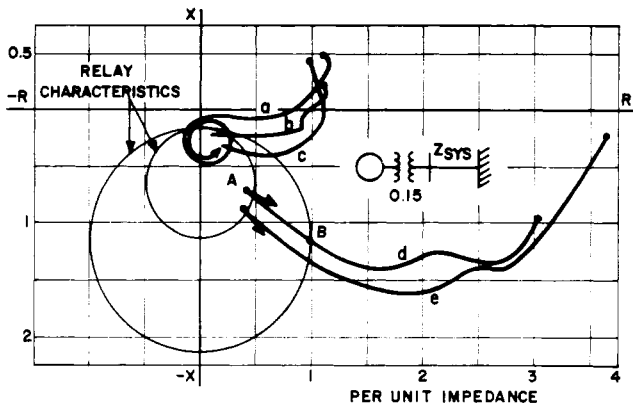

| CURVE | INITIAL LOADING (per unit) | SYSTEM IMPEDANCE |
|-------|----------------------------|------------------|
| a     | 0.93 MVA 0.92 PF Lagging   | 0.4 PU           |
| b     | 0.98 MVA 0.98 PF Lagging   | 0.2 PU           |
| c     | 0.92 MVA 0.90 PF Lagging   | 0                |
| d     | 0.31 MVA 0.95 PF Leading   | 0.4 PU           |
| e     | 0.30 MVA 1.00 PF           | 0.2 PU           |

Fig. 2. Loss of Excitation Characteristics for a Tandem Compound Generator.

As noted in the diagram, curves (a), (b) and (c) show the impedance locii as a function of system impedance with the machine operating initially at or near full load. Curves (d) and (e) show the locii at two values of system impedance with the machine initially at about 30% load.

For the case of the machine operating at full load, all of the impedance locii terminate in an area to the right of the (-X) ordinate and will approach impedance values, which at the final steady-state slip, will be somewhat higher than the average of the direct and quadrature axis subtransient impedances of the generator. The final impedances will always be greater than the offset setting ( $X'_{d/2}$ ) and therefore will always fall inside the relay characteristics as shown in Fig. 2.

For system impedances of zero and 0.2 per unit, the impedance locii (b, c) go directly to this area while the impedance locus for a .4 system spirals into the area as indicated by curve (a). The traverse time from the initial load point to the relay characteristic of the impedance locii will be between 2 to 7 seconds. The .4 system locus travels the fastest (2 seconds). It should be noted that when the impedances reach the area to the right of (-X) ordinate, the machine will be operating as an induction generator at a speed of 2 to 5% above normal. It will be supplying some reduced power to the system and will be receiving its excitation (VARs) from the system. The machine slip and the power output will be a function of the machine slip-torque characteristic (which in turn is a function of machine and

system impedances) and governor characteristic. High system impedances produce a high slip and a low power output.

For the case of the machine operating initially at 30% load, the impedance swing is more gradual and only goes as far as point (A) just inside the 1.0 per unit circle before it reverses. The swing will oscillate in the region between points (A) and (B). The traverse time from the initial point to point B is around 7 to 9 seconds while the time to traverse the distance B-A can be up around 10 to 15 seconds or higher. For this initial loading, the machine speed will only be 0.1 to .2% above normal and as before it will be operating as an induction generator.

For initial machine loadings between .3 and 1.0 per unit, the impedance locii will terminate inside the 1.0 per unit circle in the region above point A. For loadings below .3 per unit the locii will terminate below point A and will only appear in the large circle (diameter =  $X_d$ ). For a loss of excitation from no load, the relay will see an impedance which in the limit will vary between the direct and quadrature axis synchronous impedances ( $X_d, X_q$ ).

**Machine Loading and Terminal Voltage:** Figure 3 shows the effect of loss of excitation on terminal voltage, power output and reactive power for a 0.1 per unit system impedance and for a machine operating initially at full load. The abscissa is given in seconds while ordinates specify per unit volts, power and VARs. It should be noted that negative VARs signify VARs into the machine.

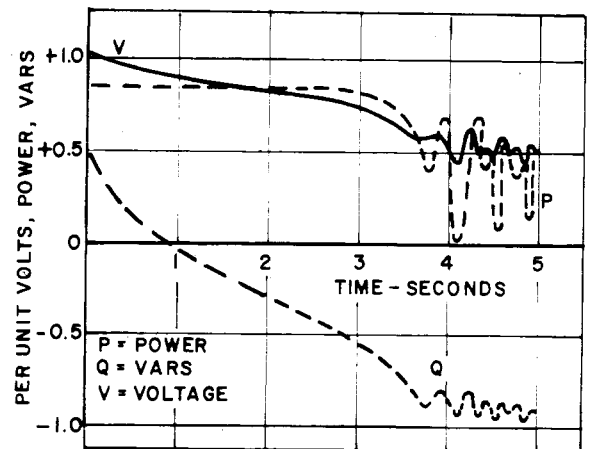

Fig. 3. Variation in Terminal Voltage, Power, Vars for Loss of Excitation on Tandem Compound Generator.

As noted in this diagram, the voltage decreases and oscillates around an average of 0.5 per unit, the power output decreases and averages about 0.3 per unit and the VARs go negative and average around -0.93 per unit.

For the case of a lightly loaded machine, the variation in loading and terminal voltage will be considerably less when excitation is lost. For example, consider the case of a generator connected to a .2 system and with an initial loading of  $P = .3, Q = -.156, V_T = 1.0$  per unit. Thirty (30) seconds after losing excitation, the lowest voltage reached was .78 per unit, the power dropped only to .275 per unit and the VARs reached -.6 per unit.

There are several points to note from these results. First, when a lightly loaded machine loses excitation, the final MVA loading will probably not be damaging to the machine but the VAR drain may be detrimental to the system. In the case discussed the final machine MVA loading is .66 per unit and the stator current only reaches .85 per unit. When the machine is initially operating at full load, a loss of excitation can be damaging to both the machine and the system. While the final loading in terms of MVA is not excessive, the machine in Fig. 3 will have stator currents in excess of 2.0 per unit. The high current is due to the fact that the resulting machine loading is at a substantially reduced terminal voltage. Of course, the VAR drain from the system can depress system voltages and thereby affect the performance of other generators in the same station or elsewhere on a system. In addition, the increased reactive flow across the system can cause tripping of transmission lines and thereby adversely affect system stability. For example, in 1951 a utility reported<sup>4</sup> that the loss of excitation on a 50 MW generator caused system wide instability, the tripping of interconnections and tie lines and over 100

breaker operations before the disturbance subsided. In this case, it was evident that other generators and interconnections could not stand the additional reactive load imposed on the system. The possible effects on other generation will be discussed in a later section.

### Loss of Excitation - Cross Compound Generators

The cross compound generator studied was a typical 900 MVA conductor-cooled machine. It was assumed, the high and low pressure units were bussed at generator voltage and connected to a high voltage system via a .15 per unit transformer.

As perhaps might be expected, the loss of excitation characteristics for cross-compound units follow much the same pattern as those for a tandem generator. With a loss of excitation on either the high pressure (HP) unit or the low pressure (LP) unit, the impedance locii as a function of system impedance and initial loading are similar in all respects to those for tandem units. The behavior of the sound unit in the cross-compound arrangement (that is, the unit which still has excitation) will be a function of system impedance and of whether or not a voltage regulator is in service. To illustrate the similarity in characteristics, Fig. 4 shows the loss of excitation characteristics for a cross-compound generator connected to a .2 system and with initial loadings of .95 MVA and .3 per unit MVA. In both cases, it was assumed the low pressure unit lost excitation and the effect on the high pressure unit was determined with and without regulator.

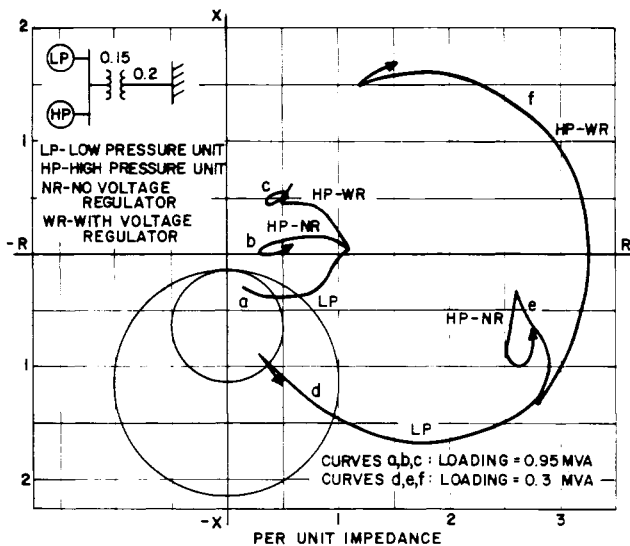

Fig. 4. Loss of Excitation Characteristics for a Cross Compound Generator.

As before, for a .95 MVA initial loading, the impedance locus (curve a) terminates to the right of the (-X) ordinate. The locus with an initial loading of .3 per unit (curve d) again just reaches inside the 1 per unit circle.

As noted by curves (b, c, e, f) in the diagram, the impedance locii of the sound unit (high pressure unit) will vary appreciably depending on whether or not the voltage regulator is in service. On the other hand, the loss of excitation impedance locus for the low pressure unit is essentially the same with or without a regulator in service on the high pressure unit.

In this case and for lower system impedances, the high pressure unit will not lose synchronism. However, with a 0.4 system impedance and with the voltage regulator out of service, the high pressure unit will pull out of step with respect to the system. With the voltage regulator in service, the high pressure unit will remain in synchronism.

A loss of excitation on the high pressure unit produces impedance locii which are almost identical to those shown in this figure. **Machine Loading and Terminal Voltage:** The loss of excitation on a unit in a cross-compound generator imposes a more severe duty on the generator than in the case of a tandem machine. The most severe duty occurs when the generator is initially at full load, when the system impedance is .2 and below, and when the voltage regulator is in

service on the sound unit. With these conditions, the unit that has lost excitation can have a peak MVA loading over 2.0 per unit and peak currents in excess of 2.5 per unit. The sound unit can have peak MVA loadings above 1.5 per unit and peak currents approaching 2.0 per unit.

Even with the voltage regulator out of service, the unit that has lost excitation can have peak MVA loadings that approach 2.0 per unit and the peak currents that approach 2.5 per unit. The large variations in power and VARS that can occur are illustrated in Fig. 5 for the cross-compound unit connected to a .2 system. Figure 5 shows the variation in terminal voltage, power and VARS when the low pressure unit loses excitation and the voltage regulator is in service on the high pressure unit.

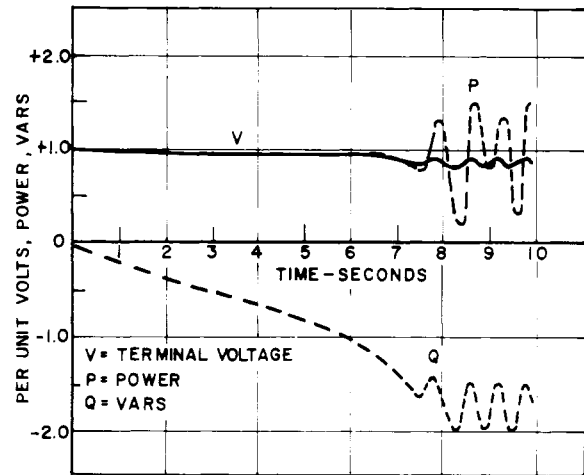

Fig. 5. Variation in Terminal Voltage, Power, Vars for Loss of Excitation on Low Pressure Unit for a Cross Compound Generator.

When the generator is initially operating at .3 per unit power the loading and current do not exceed 1.0 per unit but the VARS taken from the system can exceed .5 per unit. With or without a voltage regulator in service, the terminal voltage is still above .9 per unit after 60 seconds and the slip is negligible.

### Effect on Generators in the Same Station

To study the effect on a "sound" machine after another machine in the same station loses excitation, it was assumed two similar tandem compound generators were connected to a high voltage system through separate step-up transformers as shown in Fig. 6. It was also assumed both machines were initially fully loaded and that machine (A) lost excitation. The effect on machine (B) was determined for three values of system impedance ( $Z_{sys} = .05, .2, .4$ ), with and without a voltage regulator in service on machine (B).

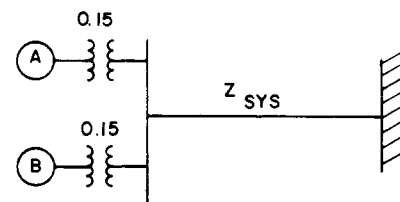

Fig. 6. Two Tandem Compound Generators in Same Station.

This study showed that when the system impedance is low ( $Z_{sys} = .05$ ), the loss of excitation on machine (A) will have little effect on machine (B). Without a voltage regulator, the terminal voltage on (B) will drop about 5% but the power and VAR output will remain essentially constant. With a voltage regulator, the VAR output from (B) increased slightly going from  $Q = +.09$  to  $Q = +.3$ .

When the system impedance is increased to  $Z_{sys} = .2$ , there is a greater effect on the performance of machine (B). Without a regulator, the terminal voltage and machine output will vary appreciably. During a 5 second time interval, the terminal voltage dropped 20%,

the power output decreased to .75 per unit and VAR output increased to .3. However machine speed only increased .2% and the maximum angular swing was  $20^\circ$ . With a voltage regulator in service, there was a 5% variation in terminal voltage and a negligible effect on machine speed. However there was an appreciable increase in machine (B) loading, mainly due to an increased VAR output. During a 10 second interval, the machine MVA loading reached a peak of 1.4 per unit and remained in the range of 1.1 to 1.3 per unit for several seconds. The voltage regulator remained at ceiling for 7.0 seconds.

With a system impedance of .4 there is a pronounced effect on the performance of machine (B). Without a voltage regulator, machine (B) will lose synchronism in about 1.0 second after machine (A) slips a pole. The loss of excitation and loss of synchronism characteristics for both machines are shown in Fig. 7. With a voltage regulator, machine (B) maintains synchronism but the MVA loading reached and remained around 1.4 per unit for at least 5 seconds.

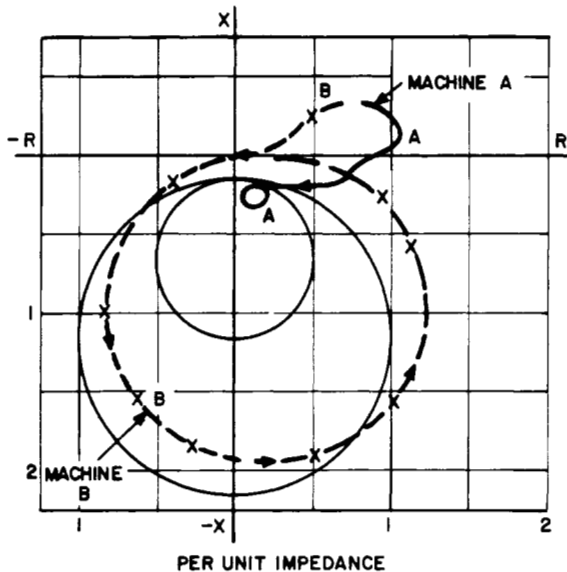

Fig. 7. Loss of Excitation - Machine A  
Loss of Synchronism - Machine B

While it would appear from the above results that the loss of excitation on one machine will only affect a nearby machine when the system impedance is unusually high, it should be recognized that this was a limited study which did not consider all possible machine characteristics, system configurations and the interaction effects of other generators. There has been at least one case reported where a loss of excitation on a machine caused a generator in a nearby station to lose synchronism and the equivalent system impedance was .2 or less. The study does indicate however the effectiveness of the voltage regulator in maintaining machine stability during these conditions.

#### PERFORMANCE DURING TRANSIENT SWINGS

From time to time, there have been reports that the loss of excitation relay had operated during a stable transient swing after the clearing of a nearby external fault. An investigation of each case revealed that either the connections to the relay were incorrect or that an incorrect voltage was applied to the relay. In effect, the relay was "looking" out into the system and not into the generator. In several cases, the loss of excitation relay had actually detected a loss of synchronism which was caused by prolonged fault clearing times.

In spite of the excellent performance of the loss of excitation relay in this regard, the concern that the relay might operate incorrectly during stable swings has persisted. In view of this concern, an investigation was made to determine the proximity of stable swings to the relay characteristic.

The impedance swing characteristic as viewed from the generator terminals was determined for stable transient swings after the clearing of a three phase fault on the high voltage side of the step-up transformer. Both tandem and cross-compound generators were considered in the study. For various machine parameters the impedance

swing was determined as a function of fault clearing time, system reactance and whether or not a voltage regulator was in service. After a number of computer runs, it soon became evident that the "worst" swings occurred when:

1. The voltage regulator was out of service.
2. The system impedance was low.
3. The fault clearing times were equal to the critical switching times. (That is, the maximum switching time for which the machine is just stable.)
4. The machine was initially operating at a leading power factor.

In this instance, "worst" swing refers to the impedance locus which comes closest to the relay characteristic.

To illustrate the extent of the swings, Fig. 8 shows the impedance swing locii as viewed from the terminals of the tandem compound generator used in the previous discussion.

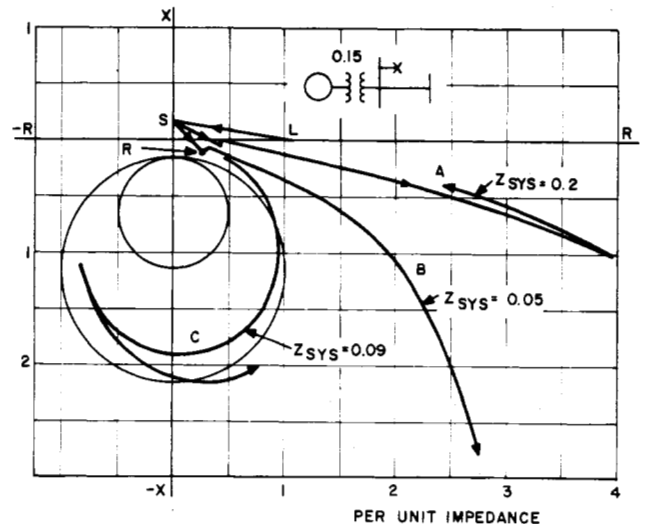

Fig. 8. Stable Transient Swings - Tandem Compound Generator.

This figure gives the impedance locii for three values of system impedance and for two machine loadings: full load - unity power factor; full load - .95 leading power factor. In all cases, the voltage regulator was out of service and critical switching times were used. The point L indicates the initial load impedance; point S the short circuit impedance ( $S = X_T$  in this case), and point R the apparent impedance the instant the fault is cleared. The change from L to S and from S to R is instantaneous.

Curves A and B show the impedance locii for the case of the machine operating at full load - unity power factor. For the .2 system, the impedance locus swings up and away from the relay characteristic. The swing makes several oscillations before settling down to the initial load point. For the .05 system, the impedance locus swings closer to the relay characteristic and actually makes a more extensive excursion than indicated in the diagram. In this case the impedance locus will cross the (-X) axis at 6.0 per unit and swing into the -R region before returning to the initial load point.

Curve C is for the case where the machine is operating at a .95 leading power factor. As shown in this diagram, it is possible for a stable swing to enter the relay characteristic. In this instance, the impedance locus enters the large relay setting and stays inside the relay characteristic for 0.3 seconds. It should be emphasized that this swing was due to clearing a fault at the critical switching time which was 0.18 seconds in this case. For faster clearing times, less leading power factors and for unity or lagging power factors, the transient swings remained outside the relay characteristic.

Another point for consideration in these swing curves is point R, the apparent impedance after the fault is cleared. As shown on this diagram, the lower the system impedance, the closer this point

comes to the relay characteristic. While this point can come close to the relay characteristic, it did not enter the relay circle in any of the cases studied.

With no regulator in service or with a slow response regulator, the point R will invariably appear below the R axis. This is due to the fact that when the fault is cleared, the generator will be operating at a higher angle on the power-angle curve and therefore the power output will be above 1.0 per unit. For loading conditions around unity power factor the machine internal voltage will be less than 1.0 per unit and therefore this power transfer will be accompanied by a VAR transfer from the system into the machine. For example, for the .05 system, the power, VARS and voltage at the machine terminals at the instant the fault is cleared is  $P = 1.6$  per unit,  $Q = -.8$  per unit,  $V_t = .71$  per unit.

The use of a fast response voltage regulator would be beneficial since it tends to drive the point R and the impedance locus away from the relay characteristic.

It should be noted that while the above discussion was limited to tandem generators, cross-compound units will have almost identical impedance swing characteristics.

### Unstable Swings

With the increasing concern about possible generator loss of synchronism, a number of utilities have proposed to use the loss of excitation relay to detect this condition. As an adjunct to the preceding study, a number of cases were run to determine if the loss of excitation relay would indeed detect a loss of synchronism under all conditions. Both tandem and cross-compound generators were considered and the impedance locus was determined as a function of system impedance. The effect of voltage regulators was also considered.

The results of the study are summarized in Figs. 9 and 10. Figure 9 shows the impedance loci for a tandem machine connected to a 0.2 and 0.4 system. Curve A gives the impedance locus for a machine without voltage regulator connected to a .2 system. As shown, the impedance locus will enter the relay setting which is proportional to synchronous reactance and the relay may trip for this condition. However, with a voltage regulator in service, the impedance locus, Curve B, increases in diameter and just barely enters the relay characteristic. Actually, on subsequent swings the locus increases in diameter and remains outside the relay characteristic. These curves also apply for a cross-compound generator connected to .05 and .1 systems.

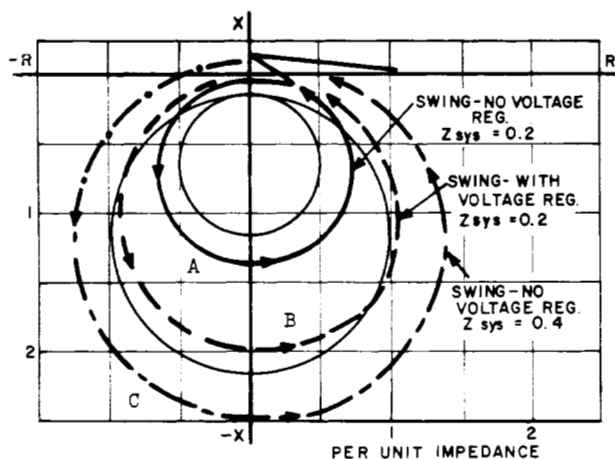

Fig. 9. Loss of Synchronism Characteristics for a Tandem Compound Generator.

Curve C shows the impedance locus, without regulator, for a tandem machine connected to a .4 system. This locus remains outside the circle and gets larger when a voltage regulator is used.

Figure 10 shows the impedance loci for a cross-compound generator connected to either a .2 or a .4 system. It is apparent that neither the low pressure or the high pressure units would detect this swing.

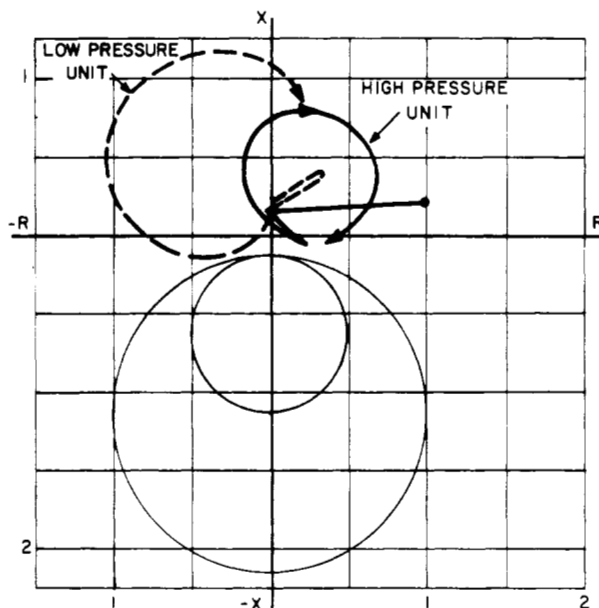

Fig. 10. Loss of Synchronism Characteristics for a Cross Compound Generator.

The obvious conclusion is that the loss of excitation relay can not be relied on to detect a loss of synchronism and therefore some other form of relaying should be used.

### PERFORMANCE DURING LOW FREQUENCY DISTURBANCES

During the major disturbances in the Northeast of a few years ago, a number of generators were tripped from the systems by the loss of excitation relay. At the time, it was not possible to pinpoint the cause of these trippouts because of the lack of recorded data on system and generator conditions. However, a post-mortem investigation revealed the following:

1. The trippouts occurred many minutes after the disturbance started.
2. System frequency was low.
3. The generators were either initially on manual control or had been switched to manual control after the voltage regulators had exceeded the time limit at ceiling operation.
4. All of the generators had excitation systems whose output was a function of frequency (for example, shaft driven exciters).

On the basis of this information, it was possible to show that the relays had not operated incorrectly or unnecessarily, but in effect had detected either a loss of excitation or a loss of synchronism. A qualitative analysis indicated that the exciter characteristics as a function of frequency (speed) could cause a loss of synchronism or practically a complete loss of excitation. To illustrate this point consider the exciter output characteristic shown in Fig. 11.

This figure shows voltage output as a function of speed (or frequency). At normal frequency and on manual control, the exciter will be operating on the 1.0 per unit curve and at the point where the rheostat line intersects this curve. As the speed (and frequency) decreases, the output of the exciter will decrease and at some speed the exciter saturation curve will become tangent to the rheostat line which remains fixed in position. The point of tangency will be at zero armature volts which of course would mean a collapse of the generator field voltage and a complete loss of excitation. Even if the field voltage does not collapse immediately, the gradual decrease in exciter voltage could cause the machine to pull out of step.

To verify the conclusions reached in the qualitative analysis, a limited study was made to determine quantitatively the performance of a generator during this type of disturbance. For purposes of this study it was assumed that a 475 MVA tandem compound generator was connected to a system ten times larger, 4750 MVA. It was

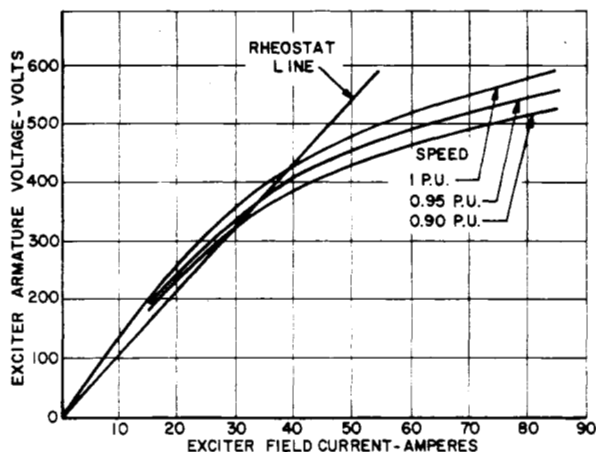

Fig. 11. Typical Saturation Curve for a 500 Volt Shaft Driven Exciter.

further assumed that the machine was initially fully loaded, it was on manual control and that the exciter output was a function of speed (frequency). The disturbance was initiated by sudden increase in load and the impedance locus as viewed at the generator terminals was determined as a function of system impedance. The results of this study are shown in Fig. 12 for two values of system impedance  $Z_{sys} = .2$  and  $.4$ . Curve A gives the locus for a  $.2$  system while curve B is for the  $.4$  system. For system impedances below  $.2$ , the impedance locus follows much the same pattern as for the  $.2$  system.

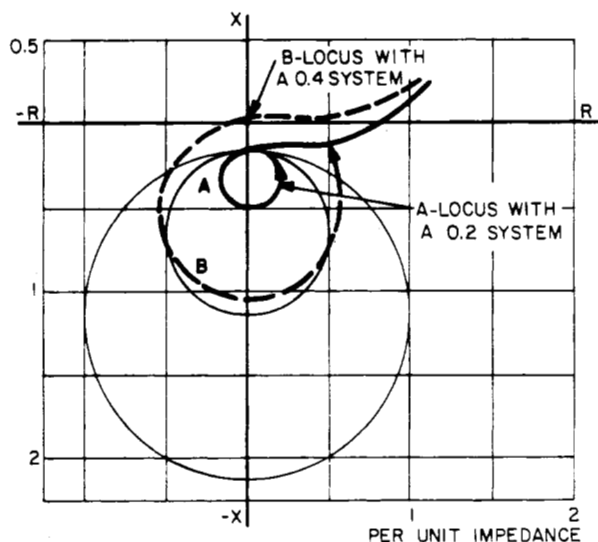

Fig. 12. Impedance Loci During an Underfrequency Disturbance - Tandem Compound Generator.

The impedance loci shown are actually loss of synchronism characteristics which would cause relay operation. For the exciter characteristic used, a 10 to 15% reduction in excitation voltage caused the generators to pull out of step. With the  $.4$  system the generator lost synchronism at approximately 58 Hz while with the  $.2$  system, synchronism was lost at approximately 57 Hz.

It should be noted that at reduced frequency the relay characteristic will shift into the third quadrant and the relay reach and offset will be slightly reduced. At 57 Hz, the angle of maximum torque is at  $-105^\circ$ , the offset is reduced 5% and circle diameter is reduced 10%. However, even with this reduction and shift in characteristic, the relay would still operate for the impedance loci shown.

The above results would indicate that the phenomenon involved is essentially one of instability. The fact that the loss of excitation relay can detect an unstable condition was and still is considered a desirable operation. In the case of the major Northeast disturbances

none of the generators involved had loss of synchronism protection and tripping by the loss of excitation relay in all probability prevented machine damage. Moreover, it should be noted that the final impedance locus (curve A in Fig. 12) covers a limited area and therefore may not be detected by some conventional loss of synchronism relays.

While this has been a limited study, it might be noted these results substantiate some of the post-mortem data that indicated the loss of excitation relay had tripped machines at or near 57 Hz during the major disturbances.

### GENERATOR PROTECTION CONSIDERATIONS

While the preceding data is based on a study that, of necessity, has considered a limited number of generator and system parameters, several conclusions can be drawn with regard to loss of excitation protection:

1. It is readily apparent that a loss of excitation can be damaging to the generator as well as detrimental to the overall operation of the system. Therefore, loss of excitation protection should be provided on all types of generators.
2. To detect a loss of excitation with any machine loading, the relay characteristic should be set with a circle diameter equal to direct axis synchronous reactance ( $X_d$ ) of the generator.
3. The offset mho loss of excitation relay can detect a generator loss of synchronism for some system conditions. However, the relay will not detect a loss of synchronism under all system conditions and therefore separate loss of synchronism relaying should be provided to protect the generator.
4. Consideration should be given to the effect of stable swings on relay performance.

With regard to the last point, it should be noted that whether or not a stable swing will enter the relay characteristic is a function of generator loading (magnitude and power factor), generator and voltage regulator characteristics, and system impedance. The effect of these parameters on relay performance should be evaluated by the study of a specific generator and system.

Another factor of concern to some users is the performance of the voltage regulator when operating on the underexcited limit. There is apprehension that the regulator will "undershoot" while trying to maintain the limit and thereby cause a momentary excursion of the apparent impedance into the relay characteristic. While this has not been a widespread problem, users have reported that this possibility exists for some types of regulators.

The selection and application of loss of excitation protection requires the consideration of two factors:

1. Effect of stable swings.
2. Voltage regulator performance.

If an evaluation of these factors indicates that undesired operations will not occur, then a single offset mho characteristic should suffice to provide protection. The relay would be set with an offset equal to one-half the direct axis transient reactance ( $X'_d/2$ ) and the circle diameter equal to direct axis synchronous reactance ( $X_d$ ) as shown in Fig. 1. This setting will detect a loss of excitation due to an open or shorted field circuit from any initial generator loading. Aside from the small time delay incorporated in the relay, no additional external time delay should be used because of the possible adverse effects on the machine and/or system. It should be noted that the time to damage for large conductor-cooled machines is considerably less than that for conventionally cooled machines.

On the other hand, if stable swings or voltage regulator performance are a concern, undesired tripping can be avoided by the use of two relay characteristics set as shown in Fig. 13. One relay would be set with a diameter equal to 1.0 per unit impedance on the machine base and this relay should be permitted to trip without any added external time delay. This unit will provide fast protection for a loss of excitation with high initial machine loadings, the more severe condition in terms of possible machine damage and adverse effects on the system. The 1.0 per unit impedance is an arbitrary value that establishes a circle that will provide protection for machine loadings in the range of 30 to 100 percent.

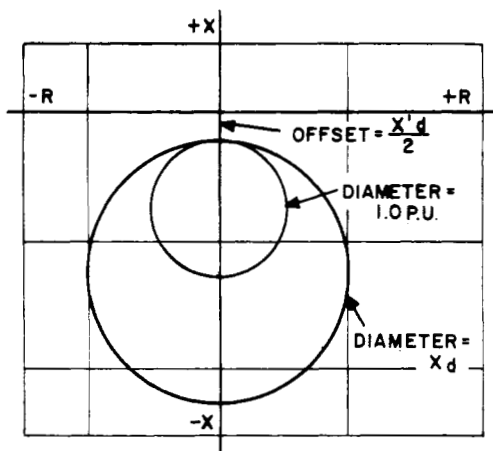

Fig. 13. Generator Protection Using Two Loss of Excitation Relays.

The second relay should be set with a diameter equal to direct axis synchronous reactance ( $X_d$ ) and some external time delay should be used to ride over the transient conditions that might cause undesirable operation. This setting will detect a loss of excitation when a generator is lightly loaded, a less severe condition. Both relays would be set with an offset equal to one-half direct axis transient reactance ( $X'_d/2$ ).

This combination of relays will detect a loss of excitation due to an open or shorted field circuit from any initial generator loading and provides maximum security against undesired operations.

The amount of time delay used with the large setting should be the minimum time required to ride over transient conditions. A time delay of 0.5 or 0.6 seconds appears to be sufficient to ride over stable transient swings. While there is no data available on the transient performance of voltage regulators, it would appear that a 1 to 3

second external time delay should prevent undesired operation due to voltage regulator undershoot.

In either case, when selecting a time delay the user should determine the effect of the time delay on possible generator damage and on the overall operation of the system. It should be noted that even in the case of a lightly loaded generator, a loss of excitation can cause a considerable VAR drain from the system (up to .5 or 0.6 per unit on machine MVA base). A prolonged VAR drain may cause the tripping of transmission lines and general system instability.

In conclusion, it should be emphasized that there is need for users to study the effects of generator loss of excitation on system operation and to evaluate the performance of the loss of excitation protection for each generator. In the generalized study presented here it was not possible to consider the effects of all combinations of generator designs, voltage regulator characteristics, system parameters or the interaction effects of the other generators. These effects can only be completely determined by the study of a generator connected to a specific system.

#### ACKNOWLEDGEMENTS

Grateful acknowledgement is extended to C. Concordia for his guidance and to E. H. Lenfest for his computer study efforts.

#### REFERENCES

- (1) C. R. Mason, "A New Loss of Excitation Relay for Synchronous Generators," *AIEE Trans.*, vol. 68, pp. 1240-1245, 1949.
- (2) R. P. Schulz, W. D. Jones, and D. N. Ewart, "Dynamic Models of Turbine Generators Derived from Solid Rotor Equivalent Circuits," paper T 72 515-5, presented at the 1972 IEEE Summer Power Meeting, San Francisco, Cal., July 9-14, 1972.
- (3) C. Concordia and M. Temoshok, "Resynchronizing of Generators," *AIEE Trans.*, vol. 66, pp. 1512-1518, 1947.
- (4) A. W. Walton, "Loss of Excitation Experience on Oklahoma Gas and Electric Co. System," DP paper presented at AIEE Southwest District Meeting, April 1952.

For Combined Discussion, see page 1481.