



A review of Stirling-engine-based combined heat and power technology

Shunmin Zhu^{a,b}, Guoyao Yu^{a,*}, Kun Liang^c, Wei Dai^{a,b}, Ercang Luo^{a,b,*}

^a Key Laboratory of Cryogenics, Technical Institute of Physics and Chemistry, Chinese Academy of Sciences, Beijing 100190, China

^b School of Future Technology, University of Chinese Academy of Sciences, Beijing 100049, China

^c Department of Engineering and Design, University of Sussex, Brighton BN1 9QT, UK

HIGHLIGHTS

- Stirling engine is a feasible and promising technology for cogeneration applications.
- The Stirling engine-based cogeneration technology is thoroughly reviewed.
- Challenges and future trends of Stirling engine-based cogeneration technology are discussed.

ARTICLE INFO

Keywords:

Stirling engine
Combined heat and power
Residential
Techno-economic

ABSTRACT

Small- and micro-scale combined heat and power (CHP) technologies offer great potential for reducing energy costs and CO₂ emissions in residential and small commercial buildings. Among various CHP technologies, Stirling engines, particularly free-piston ones, show great promise in residential applications because of their remarkable advantages of low emissions, maintenance, noise, and vibration, theoretically high thermal-to-electrical efficiency, and flexibility of fuel sources. This paper presents a comprehensive review of Stirling-engine CHP in terms of different heat sources, tri-generation systems, status of commercial development, techno-economic issues, and challenges and future trends. The techno-economic assessment indicates that the relatively low on-site operational efficiencies and considerable investment costs are the main issues that hinder the further development of Stirling-engine CHP systems, and suggestions for future development are made accordingly. For successful commercial dissemination of Stirling-engine CHP, it is essential to improve the on-site electrical efficiency, reduce the capital cost of systems, and develop renewable-energy-powered and free-piston Stirling-engine-based CHP systems against the background of grid decarbonization and carbon neutrality.

1. Introduction

Worldwide, energy is consumed in major sectors such as industry, buildings, transportation, and agriculture, with buildings accounting for very high energy consumption compared with other sectors. Although percentages vary from country to country, buildings account for 30–45% of global energy demand [1]. The energy consumed in buildings is mostly for electricity and heating purposes, resulting in massive fossil-fuel consumption and CO₂ emissions. Therefore, the combination of

growing energy shortage and increasing environmental pollution is demanding ever-more efficient and environmentally friendly energy utilization technologies in buildings. In this sense, there is an urgent need to develop combined heat and power (CHP, also referred to as cogeneration) systems to provide a synergetic way to generate electricity highly efficiently. Obviously, this would reduce stress on the grid and local distribution systems, while also reducing gross energy consumption and CO₂ emissions.

The definition of CHP is a system whose by-product of electrical power generation, namely exhausted heat, is recovered effectively for

Abbreviations: AHX, ambient heat exchanger; AS, alternative system; CCHP, combined cooling, heating, and power; CCHT, Canadian Centre for Housing Technology; CHP, combined heat and power; CO, carbon monoxide; CO₂, carbon dioxide; CS, conventional system; FBC, fluidized-bed combustor; FPSE, free-piston Stirling engine; GHG, greenhouse gas; HHX, hot heat exchanger; ICE, internal combustion engine; IEA, International Energy Agency; KSE, kinematic Stirling engine; MGT, micro gas turbine; MRC, micro Rankine cycle; NO_x, nitrogen oxides; ORC, organic Rankine cycle; PEM, proton exchange membrane; PES, primary energy savings; SE, Stirling engine; SOFC, solid oxide fuel cell; TASEG, thermoacoustic Stirling engine generator.

* Corresponding authors at: Key Laboratory of Cryogenics, Technical Institute of Physics and Chemistry, Chinese Academy of Sciences, Beijing 100190, China (E. Luo).

E-mail addresses: gyyu@mail.ipc.ac.cn (G. Yu), ecluo@mail.ipc.ac.cn (E. Luo).

<https://doi.org/10.1016/j.apenergy.2021.116965>

Received 9 December 2020; Received in revised form 4 April 2021; Accepted 15 April 2021

Available online 5 May 2021

0306-2619/© 2021 Elsevier Ltd. All rights reserved.

Nomenclature

E
LHV_{fuel}
m_{fuel}
P_{net}
Q_{gen}
Q_{in}
T_H
T_L
W_{net}
ΔCO_2
η_{Carnot}
$\eta_{combined}$
$\eta_{electrical}$
$\eta_{Stirling}$
$\eta_{thermal}$

use [2]. As a typical distributed system, it avoids the losses resulting from long-distance transmission of electrical power and enables both heat and power to be produced in situ. In principle, the size of CHP ranges from large scale (up to several megawatts) to small scale (<100 kW), the target users being large industrial plants and residential buildings, respectively. Nowadays, miniaturization is an important developmental direction of CHP systems. Small-scale CHP refers to CHP systems with rated electrical power of <100 kW_e, while micro-CHP refers to CHP units with an electrical capacity below 15 kW_e [3]. Generally speaking, a CHP system includes a prime mover (an energy conversion unit), a generator, a heat recovery system, and an electrical converter. Among these components, the prime mover obviously plays a critical role, and the main types of prime mover currently used in small- and micro-scale CHP include the gas turbine (micro-turbines), internal combustion engine (ICE), Stirling engine (SE), Rankine cycle, and fuel cell [4,5].

As a type of external combustion engine, the SE is particularly suited for residential CHP applications because of its advantages of low emissions, maintenance, noise, and vibration, theoretically high thermal-to-electrical efficiency, and flexibility of fuel sources. It is precisely because of these characteristics that SE-based CHP systems have attracted increasing attention from countries around the world in recent decades.

In 2011, Harrison [6] described (i) the fundamentals of the SE and (ii) how the technology meets the needs of residential applications with reference to specific commercially available SE micro-CHP products; also provided was a view of future developmental trends of SE-based micro-CHP systems. In 2012, Ferreira et al. [7] reviewed SEs used in micro-scale CHP system applications; they discussed comprehensively the performance characteristics of SE-based micro-CHP systems, including their electrical efficiency, heat recovery capacity, and fuel consumption, and they compared the SE and other prime-mover technologies for micro-scale CHP applications. However, although both contributions provided excellent reviews of SE-based CHP system developments, they focused only on micro-scale natural-gas-fired systems and commercial developments. Furthermore, few previous reviews have emphasized the technological developments and field trials of SE-based CHP technology, let alone the techno-economic assessment of this technology. In addition, a state-of-the-art introduction to this technology as well as SE-based combined cooling, heating, and power (CCHP), also known as tri-generation, which can increase the cost- and emission-saving potential of using a CHP system) technology is lacking.

Therefore, there is a need to perform a comprehensive review work to cover this extensive gap. The main purpose of the present contribution is to review the development of SE-based CHP technologies for residential application. This review considers the development of

Stirling CHP in terms of heat sources, tri-generation systems, the state of commercial development, techno-economic issues, and challenges and future trends. Section 2 provides the fundamentals of SEs for CHP applications, and Section 3 describes the development of SE-based CHP systems in previous decades. Section 4 summarizes the characteristics of an SE-based CHP system, Section 5 reviews the techno-economic assessment of this technology, and Section 6 discusses the challenges and future trends of SE-based CHP technology. Finally, conclusions are drawn in Section 7.

2. Fundamentals of Stirling-engine-based CHP systems

2.1. Stirling engine

An SE is a heat engine in which working fluid (e.g., air, hydrogen, nitrogen, inert gases) undergoes a closed regenerative thermodynamic cycle consisting of two isothermal and two isovolumetric processes, to experience cyclic compression and expansion at different temperature levels, thereby realizing a net conversion of external heat energy to mechanical work [8]. The closed cycle means that the effective working fluid is permanently constrained within the engine, and the term “regenerative” describes the use of a special internal heat exchanger for transient thermal storage, namely the regenerator.

Fig. 1(a) shows the operating principle of an SE. Conventionally, a typical SE consists mainly of a displacer piston, a power piston, an ambient heat exchanger (AHX), a regenerator, and a hot heat exchanger (HHX, also referred to as a heater head). The operation of an SE is based on the Stirling cycle. From a Lagrangian perspective, the traditional comprehension of an ideal Stirling cycle is that gas parcels (working fluid) in turn experience isothermal compression (process 1–2), isochoric heating (process 2–3), isothermal expansion (process 3–4), and isochoric cooling (process 4–1) [8,9]. Fig. 1(b) shows P – V and T – S diagrams for the ideal Stirling and Carnot cycles. For the ideal Stirling cycle, its thermal efficiency is equal to the Carnot efficiency, i.e.,

$$\eta_{Stirling} = \eta_{Carnot} = \frac{W_{net}}{Q_{in}} = \frac{T_H - T_L}{T_H}, \quad (1)$$

where W_{net} and Q_{in} are the net work done and heat supplied in the Stirling cycle, respectively, and T_H and T_L are the source temperature and sink temperature in degrees Kelvin, respectively.

Note that a typical gas parcel in an actual regenerator moves sinusoidally under varying pressure and temperature, so in practice its cycle cannot be analyzed by directly referencing the ideal Stirling cycle, which includes four discrete steps covering the entire temperature span of the device. Also, because of many deficiencies including dead volumes, imperfect regenerators, heat losses, friction losses, and working-fluid leakages, an actual SE is capable of an efficiency of only 65–70% of the Carnot efficiency [8]. The many thermoacoustic studies in recent decades have given a deep insight into the inherent mechanisms behind Stirling-cycle systems. From a thermoacoustic perspective, all gas parcels along the regenerator undergo a local thermodynamic cycle, with the overall effect being absorption of heat at the heat source and rejection of heat at the heat sink, thereby forming the underlying mechanisms for converting heat into power [10,11].

Generally speaking, an SE is of either the kinematic type [Fig. 2(a)]—in which the power piston and displacer piston are connected together via a crankshaft or other kinematic mechanism—or the free-piston type [Fig. 2(b)]—in which there is no mechanical linkage between the power piston and displacer piston [12,13]. The conventional kinematic SE (KSE) uses mechanical contraptions to convert the reciprocal piston motion into rotational motion, the aim being to drive a rotary generator; however, gas contamination and leakage issues induced by the rigid transmission mean that this type of SE requires periodic maintenance as a matter of necessity. The invention of the free-piston SE (FPSE) overcame the technical barriers of the KSE by tuning the movement of the

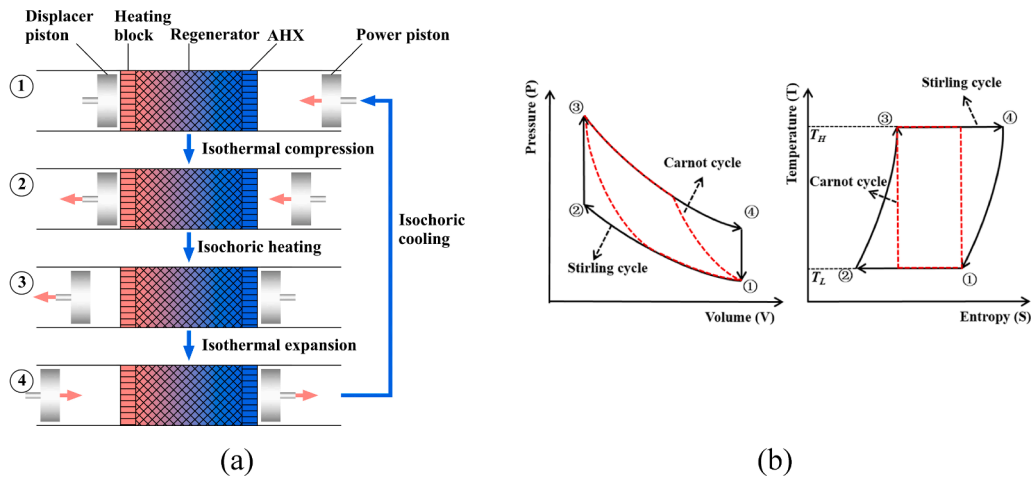

Fig. 1. (a) Operating principle of an SE and (b) P - V and T - S diagrams for ideal Stirling and Carnot cycles.

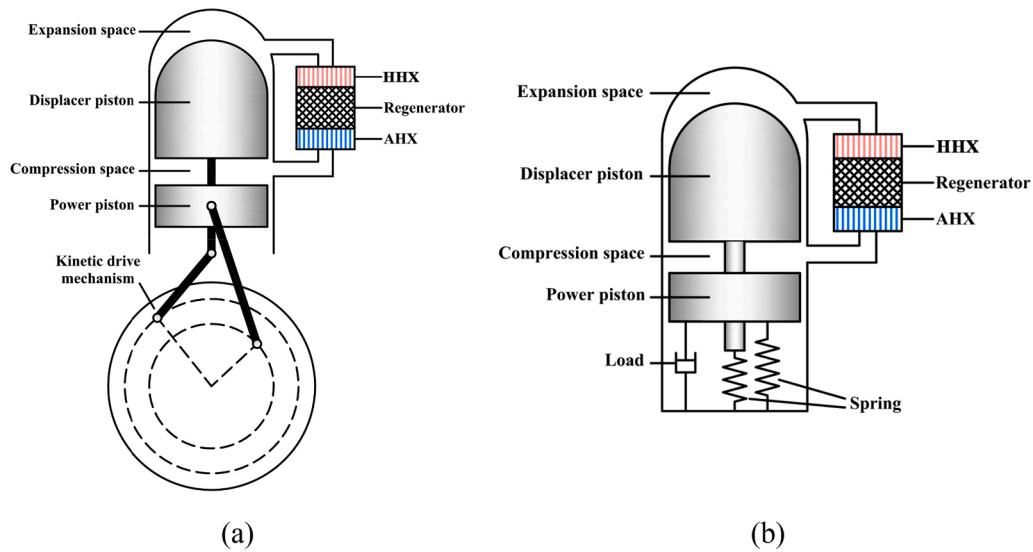

Fig. 2. Typical configurations of (a) kinematic SE (KSE) and (b) free-piston SE (FPSE).

displacer piston and power piston acoustically, thereby allowing a maintenance-free SE with a simpler configuration, higher reliability, and longer life expectancy [14]. Furthermore, SEs can also be divided into alpha, beta, and gamma types according to the arrangement of the two pistons [15].

In an ICE, fuel is injected intermittently into the cylinders, mixed with air, and then ignited. In an SE, by contrast, fuel is burned continuously outside the cylinders, and this external combustion allows an SE to use various fuel sources including conventional fossil fuels, renewable biomass (e.g., wood pellets, wood chips, agricultural residues), renewable biofuels (e.g., biodiesel, biogas, bio-syngas, hydrogen from renewables), exhausted gas, and concentrated solar power. The external combustion also makes the combustion process easy to control and allows the fuel to be burned more sufficiently, thereby meaning that the flue gas inherently contains few polluting substances. Furthermore, an SE has fewer moving components than does a reciprocating ICE, resulting in lower friction and wear and thus reducing service downtime and increasing system lifetime. Also, the lack of valves and absence of cyclic explosions mean that an SE operates more quietly and smoothly than does an ICE, thereby providing the additional benefits of low noise and vibration during operation. These characteristics make SEs well suited to the demands of micro-scale and small-scale residential CHP applications.

2.2. Stirling-engine-based CHP systems

Although the specific layout of an SE-based CHP system depends on which fuel it uses, such systems have fundamentally similar configurations. Fig. 3 shows the layout of a typical SE-based CHP system. The CHP systems are usually interconnected with a fuel distribution system, the electrical grid, and a building heat distribution system. Natural gas (or some other fuel) enters the building from the fuel distribution system, whereupon it and preheated air are mixed and ignited in the combustion chamber of a gas burner. The thermal energy of the combusted gas is then transferred continuously to the HHX of the SE, heating the internal working gas accordingly. The heated working gas accomplishes its thermodynamic cycle, producing mechanical energy and providing thermal energy for space heating and domestic hot water. The mechanical energy is then converted into electricity by a rotary or linear generator. The output electricity can be used directly in the building or exported to the electrical grid on demand. The hot exhaust gases leaving the HHX of the SE transfer residual heat to the input fresh air and recirculating water in the exhaust heat exchanger, thereby increasing the thermal efficiency of the system by recovering the waste heat.

In addition to the core SE, some manufacturers also include a thermal storage system and an auxiliary boiler that enable the system to smooth out any high thermal demand [16]. The thermal storage system can be

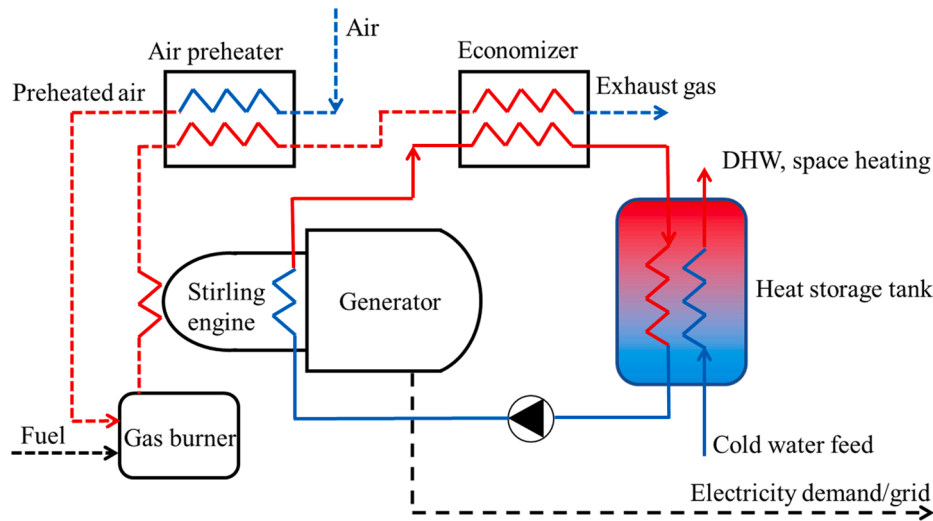

Fig. 3. Layout of typical SE-based combined heat and power (CHP) system.

used to store a fraction of the thermal energy produced by the CHP unit when the produced thermal power is higher than the instantaneous thermal demand, and the stored thermal energy can be used whenever the produced thermal power cannot meet the instantaneous thermal demand. González-Pino et al. [17] analyzed different integration approaches of thermal storage systems within SE-based micro-CHP plants, and it was concluded that parallel arrangement of the thermal storage is preferable from a multi-objective point of view. An auxiliary boiler allows the CHP system to provide a higher level of heating capacity for a given electrical output [18], thereby allowing the system to be installed in environments with higher heat demands without increasing the rated electrical output, which otherwise might lead to a higher system cost and a higher proportion of electricity being exported. Besides, an additional battery storage system is recommended for an SE-based CHP unit to achieve a higher level of electricity self-sufficiency [19], especially for some newly proposed installations which combine solar energy (through photovoltaic arrays and solar thermal collectors) and SE-based CHP unit [20,21]. In addition to these auxiliary components, a management and control system, which plays a vital role in ensuring safe, efficient and reliable long-term operation, is indispensable in an SE-based CHP system.

For an SE-based CHP system, the electrical and thermal efficiencies are defined respectively as

$$\eta_{\text{electrical}} = \frac{P_{\text{net}}}{m_{\text{fuel}}LHV_{\text{fuel}}}, \quad (2)$$

$$\eta_{\text{thermal}} = \frac{Q_{\text{gen}}}{m_{\text{fuel}}LHV_{\text{fuel}}}, \quad (3)$$

where P_{net} and Q_{gen} are the net electrical output and thermal output, respectively, m_{fuel} is the fuel flow rate, and LHV_{fuel} is the lower heating value of the fuel. The combined efficiency is the sum of the electrical and thermal efficiencies, namely

$$\eta_{\text{combined}} = \eta_{\text{electrical}} + \eta_{\text{thermal}}. \quad (4)$$

3. Development of Stirling-engine-based CHP systems

In past decades, there have been numerous studies aimed at developing superior SE-based CHP systems targeted at residential applications. The main heat sources used have been fossil fuels, biomass, solar, and waste gases, and this section reviews the development of SE-based CHP systems with these heat sources.

3.1. Fossil-fuel-powered Stirling CHP systems

3.1.1. Prototype development

Fossil fuels—especially natural gas—are the most widely used heat sources in SE-based micro-CHP systems, and past decades have seen extensive work to develop SE-based micro-CHP prototypes with a fossil fuel as the heat source. However, because of the high-precision engineering required and the considerable research and development (R&D) costs, most prototype development work has been done by companies, and so the literature contains few scientific papers related to detailed design and improvement, mainly because of commercial considerations. Instead, we review some research studies focusing on early-stage exploration and principle validation reported by universities and institutes.

In 1996 at the Technical University of Denmark, Thorsen et al. [22] designed, fabricated, and tested a 3-kW beta-type SE aimed at producing

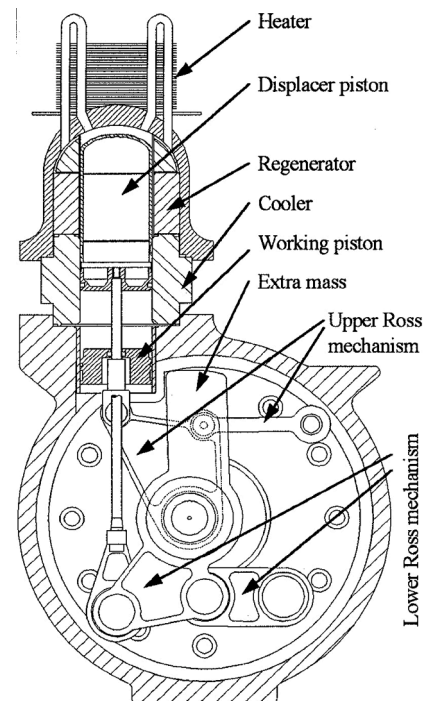

Fig. 4. Cross-sectional view of 3-kW SE developed by Thorsen et al. [22].

electricity and heat simultaneously for Danish single-family houses. Fig. 4 shows a cross-sectional view of the developed SE. The engine was designed as a hermetic unit with the crank mechanism and alternator incorporated in a pressurized crank casing, and the cross heads were eliminated in the new crank mechanism. The engine used natural gas as its fuel, and a shaft power of 3 kW was obtained at a mean helium pressure of 8.5 MPa and an outlet cooling water temperature of 35 °C, corresponding to an electrical efficiency of 23%. When the outlet cooling water temperature was increased to 65 °C, the shaft power decreased accordingly by 250 W, the engine could produce 2.3 kW of electricity, and 6.2 kW of heat was recovered by the cooling water. The same group then developed two similar SEs with an electrical power output of 9 kW [23]. The developed prototype produced up to 10 kW of electrical power, and the corresponding electrical efficiency was 24%.

The advantages of FPSEs mean that some researchers have also developed prototype CHP systems based on FPSE technology in recent years. Recently, Park et al. [24] developed and tested a kilowatt-class FPSE with a dual-opposed linear alternator for micro-CHP applications; they used natural gas as the fuel in their prototype, which could generate 962 W_e of electricity with an electrical efficiency of 23.0%. Qiu et al. [25] reported a conceptual design and performance assessment of an FPSE for a micro-CHP system; they optimized and examined key components of the engine and used the commercial Sage software to estimate the system performance, and the results indicated that the designed FPSE could provide 1 kW_e of electrical power with a fuel-to-electrical efficiency of 38.3% and 1.1 kW of thermal energy at 80 °C. Zhu et al. [26] developed and experimentally verified a numerical model to simulate an integrated FPSE-based micro-CHP system; the model accounted for acoustic impedance matching between the engine and the generator, and CHP performance tests on their micro-CHP unit revealed that when the heating water temperature was above 60 °C and the electrical power output was 2.9 kW, a combined efficiency of 87.5% and an electrical efficiency of 28% could be achieved.

In addition, some novel engine configurations targeted at CHP applications have been proposed. To increase the reliability of FPSE-based micro-CHP units and reduce their manufacturing cost, Wilcox Jr et al. [27] designed, constructed, and experimentally evaluated a dual thermoacoustic SE generator (TASEG). The configuration of their TASEG was similar to that of an FPSE (as shown in Fig. 5), while the displacer components in the FPSE were replaced with a tuned acoustic network consisting of a thermal buffer tube with porous flow straighteners at both ends. The developed TASEG prototype could output 132 W of electrical power to an electrical load with an electrical efficiency of 8.32%.

3.1.2. Laboratory tests

Meanwhile, various researchers have performed laboratory tests to obtain a better understanding of the operating and emission

characteristics of SE-based CHP systems. At the University of Toronto, Aliabadi et al. [28] examined the efficiency and emissions of a WhisperGen DC micro-CHP system fired by either diesel or biodiesel. The system operated with diesel achieved an electrical efficiency of 11.7% and a thermal efficiency of 78.7%; when operated with biodiesel, the corresponding electrical and thermal efficiencies were 11.5% and 77.5%, respectively, which were slightly lower than those when running on diesel. In addition, both the particulate emissions and uncombusted hydrocarbon when running on biodiesel were higher than those when running on diesel, which was caused by a fraction of unevaporated biodiesel that did not burn and remained in the exhaust gas. In other work carried out by the same group [29,30], the CHP performance and emission parameters of the same micro-CHP system fueled by diesel and ethanol were tested. The CHP performance test results indicated that the engine operated with ethanol had lower electrical efficiency and higher thermal efficiency than that operated with diesel during the steady state. The use of continuous premixed combustion meant that negligible particulate emissions were monitored for both fuels. During the start stage with diesel, both unburned hydrocarbon emissions and species emissions were found to be much lower than those with ethanol, and the emissions of CO and NO with diesel were found to be much higher than those with ethanol.

Rogdakis et al. [31] conducted a thermodynamic analysis and experimental study of a SOLO V161 Stirling micro-CHP module. The thermodynamic analysis used a computer code based on an ideal adiabatic model [32]. They performed an experimental investigation under different heat load stages, working pressure, and electrical power output; the results indicated that the CHP performance of the Stirling unit was promising and that the CHP unit was adequate for various application areas, and the calculated primary energy-saving ratio of such a unit was 36.8%.

Valenti et al. [33] conducted an experimental and numerical study of a natural-gas-fired commercial micro-cogeneration Stirling unit that was capable of generating 8 kW of thermal power and 1 kW of electricity. The developed numerical model in their work was modified based on the model due to Urieli and Berchowitz [32], and the unit was analyzed under different working fluid initial pressure. The results showed that the working fluid initial pressure had a strong effect on the net electrical power output and efficiency. Optimal performance with an electrical power output of 943 W and an electrical efficiency of 9.6% was achieved at a working pressure of 22 bar. Also, a maximum thermal power output of 8420 W was achieved at a working pressure of 24 bar, which corresponded to a thermal efficiency of 84.7%. In other work, Valenti et al. also analyzed the unit experimentally under on-off cyclic operations to facilitate the management of the CHP unit in practical applications [34].

In experiments, Remiorz et al. [35] compared the thermodynamic and economic effectiveness of a natural-gas-fired FPSE-based micro-CHP unit (produced by Microgen) with that of a commercial heat pump

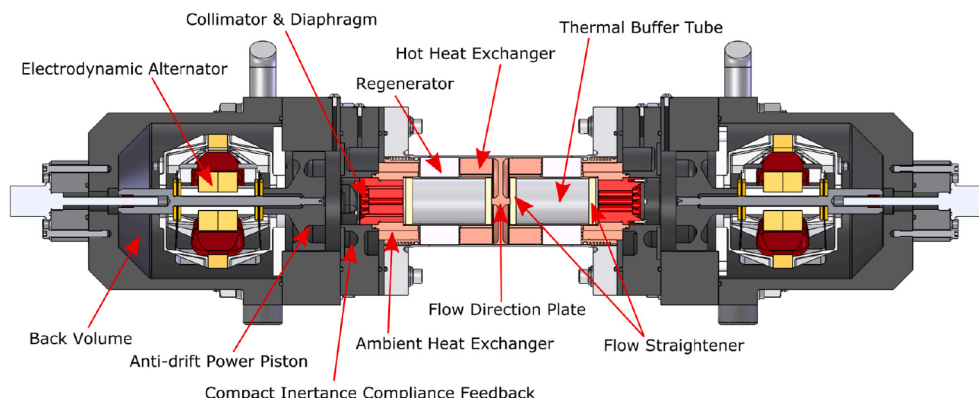

Fig. 5. Cross-sectional view of dual TASEG [27].

system (Viessmann Vitocal 300G heat pump). The economic evaluation revealed that the operating cost of the micro-CHP unit was approximately 60 PLN more than that of the heat pump system throughout the heating season. They also analyzed how natural-gas and electricity unit prices affected the financial benefit, and the results indicated that compared with operating with a heat pump, reducing the gas price or increasing the electricity purchase price by 2% saved money when running a micro-CHP unit.

3.1.3. Field trials

After laboratory tests, some field trials were performed to investigate the potential benefits of SE-based CHP systems and understand the technical, commercial, and regulatory barriers to their application. Those field trials were focused mainly on commercial SE-based micro-CHP units fueled by natural gas.

In 2003, an SE-based micro-CHP system was developed and tested at the Canadian Centre for Housing Technology (CCHT). A research house at CCHT was modified to incorporate the micro-CHP unit, which provided the house with space heating, hot water, and electricity while supplying the grid with any excess electricity [36–38]. The micro-CHP unit chosen for that field trial was the natural-gas-fueled SE developed by Whisper Tech, which had an electrical capacity of 750 W and a thermal output of 6.5 kW. The unit was connected to an external electrical network, and the generated heat from the unit was collected, stored, and used via a specifically designed thermal utilization module. Tests were carried out from March to June in 2003, and the results indicated that the CHP unit could (i) supply all of the space and water heating loads in most circumstances, (ii) meet a considerable percentage of the house's electricity requirements, and even (iii) export electricity to the grid on occasions. The average overall performance of the micro-CHP unit was 82%, with 6% in electrical efficiency and 76% in thermal efficiency. The thermal utilization module designed for this demonstration averaged an efficiency of around 57%, resulting in a total system efficiency of around 50%. While generating by-product electricity, the efficiency of the CHP system was shown to compare favorably with that of domestic water heaters fired by natural gas, and the efficiency could be improved by optimizing the design of the thermal utilization module.

Also in 2003, the Carbon Trust launched the first major field trial of micro-CHP units in the UK. In total, 87 micro-CHP units—comprising 72 domestic SE-based units and 15 ICE-based units—were installed and monitored in both domestic and small commercial applications in the UK [18], and 36 condensing boilers acted as a baseline for comparison. The SE-based micro-CHP units used in the field trial were provided by WhisperGen, Microgen, and Disenco. To capture a full year of continuous operation to investigate the seasonal variation in performance, key parameters of the micro-CHP units (e.g., electricity consumed, gas consumed, electricity generated, heat generated) were sampled every 5 min. The measured mean annual electrical and thermal efficiencies of the SE-based micro-CHP units were 6% and 71%, respectively. The measured thermal efficiencies of the SE-based units were roughly 10–15% lower than that of the condensing boilers, this being because some of the heat generated by the SE was used to generate electricity. Also, the measured thermal loss through the case of an SE-based micro-CHP unit was noticeably higher than that of one of the condensing boilers [39].

In another field trial carried out in the UK, 11 SE-based micro-CHP units (Baxi Ecogen) were tested from December 2012 to March 2014 within the Customer-Led Network Revolution project [40]. The results of that field trial showed that installing micro-CHP units can meet 34% of total annual household electricity demand on average. Compared with the average carbon intensity of grid electricity, the carbon savings for each unit were 3–12%, which were lower than the manufacturer's claim. Additionally, the average annual monetary saving was £217. The findings indicated that the tested SE-based micro-CHP unit performed poorly in terms of reducing energy bills, especially considering its

considerable capital cost [41].

In Germany, the Institute for Energy Economy and Application Technology and a co-partner carried out a field trial of four gas-fired FPSE micro-CHP (Remeha eVita) units [42]. The rated electrical power and thermal power of the CHP units used were 1 kW_e and 23 kW_{th} (including an auxiliary burner with a rated power of 18 kW_{th} for thermal peaks), respectively. The four units were installed individually in four different family houses at the end of 2009 and operated for over a year. The test results showed that the micro-CHP units worked with a net electrical efficiency of 12.2% and a combined efficiency of greater than 90%.

In summary, natural-gas-powered SE micro-CHP systems constitute a research hotspot in SE-based CHP technology. Early research activities were focused mainly on KSE-based CHP systems, whereas research activities are now shifting to FPSE-based CHP systems because of the remarkable advantages of FPSEs. Although laboratory tests showed that natural-gas-powered SE-based micro-CHP units have promising performance, some field trials found relatively low on-site electrical efficiency, implying that several technical challenges remain to be overcome before a superior natural-gas-powered SE-based CHP system can be developed successfully.

3.2. Biomass-powered Stirling CHP systems

Biomass (including solid biomass, liquid biofuel, and biogas) is the most plentiful and prominent of all renewable energy resources, with sustainable biomass use regarded as one of the most intriguing options for dealing with environmental issues [43]. Their external combustion and high compatibility with biomass fuels make SEs the ideal CHP technology for biomass use [44]. Therefore, coupling a biomass system with an SE to obtain a CHP system has attracted increasing attention in recent decades.

In 1996, the Technical University of Denmark and its cooperative partners began to develop and optimize a biomass-powered CHP plant based on a four-cylinder double-acting SE with a rated electrical power output of 35 kW [45–47]. The four cylinders were arranged in parallel in a square compartment (as shown in Fig. 6). Meanwhile, each heater was designed as a panel, and the four panels formed a square combustion chamber from which radiation heat was transferred directly to the panels. The working gas of the SE was helium with a charge pressure of 4.5 MPa. To avoid seal and gas contamination issues, the engine was designed as a hermetically sealed unit with the asynchronous generator incorporated in a pressurized crankcase. This design is similar to that of the 3-kW engine prototype developed by the same group [22]. During test runs, the CHP plant achieved an electrical efficiency of 9.2% and a combined efficiency of 90.0% [48]. Such a unit coupled with a wood-chip gasifier was installed in the Castel d'Aiano campus in Italy for the combined production of heat and power; the rated thermal output



Fig. 6. Picture of 35-kW SE [48].

power and electrical power of the whole plant were 140 and 35 kW, respectively, and for a working time of 6000 h, the wood-chip consumption of the CHP plant was 450 tons [49]. In another European Union research project carried out by the same team, a CHP plant with a 75-kW_e eight-cylinder SE was developed and demonstrated [50]; the nominal thermal power output of the CHP plant was 475 kW, and the electrical efficiency of the whole CHP plant measured in tests was 10–12%.

In Japan in 2004, the Chubu Electric Power Co. Inc. and its co-partner began to develop a wood-powder-powered SE CHP system; that CHP plant combined a 55-kW_e SE from Stirling Thermal Motors Power with a 400-kW wood-powder combustion system. Nishiyama et al. [51] conducted a wood-powder combustion test and evaluated the burner design parameters for the CHP plant. They predicted that at an air ratio of 2.0 or larger, the SE could produce an electrical power output of 55 kW_e. They also studied how the air ratio, burner type, combustion-chamber length, and air preheating temperature affected the CO and NO_x emissions. Later, Sato et al. [52] carried out demonstration tests on the 55-kW_e SE CHP plant (as shown in Fig. 7) by using wood powder as fuel. The test results were satisfactory except for the unavoidable ash-fouling problems in SE heater tubes and fins. Therefore, they suggested that in addition to optimizing the combustion temperature and the engine inlet gas temperature, an ash-cleaning system should be added.

In 1999, Sunpower Inc. developed a biomass-fired SE residential CHP product named Biowatt™ [53] that included an FPSE, a two-stage

biomass pellet burner, and cooling and starting subsystems. The biomass fuel was first pyrolyzed at a gasifier to generate fuel-rich gas, then the fuel-rich gas mixed with a secondary air jet in a burn tube and burned completely therein. The FPSE used some of the resulting heat to drive a linear alternator. The remaining heat was used (i) in a recuperator to preheat the incoming combustion air and (ii) for hot water and space heating. The developed prototype could produce over 1 kW of electrical power output and 4 kW of heat.

Damirchi et al. [54] developed a gamma-type KSE-based micro-CHP system for domestic applications. At a charge pressure of 0.1–1.2 MPa, the experimental power output was compared with results calculated using Schmidt analysis, and good agreement was achieved. They found that increasing the engine speed and charge pressure in the experiments increased the engine frictional losses. They also tested different types of biomass including bagasse, pruned wood, switch grass, poplar, and sawdust, and sawdust gave the maximum electrical power of 46 W.

By recuperating the residual heat of the combustion flue gas, Renzi and Brandoni [55] sought to increase the electrical efficiency of a 1-kW_e biogas-fed Stirling CHP system. They used a spiral gas–gas heat exchanger to recover the heat of the exhaust and reduce the biogas consumption accordingly, which increased the electrical efficiency of the SE-based micro-CHP unit by up to 22.5%. They also developed an energy management algorithm and applied it to a residential case study with the aim of assessing the validity of their solution. The results indicated that it is cost-effective to use a high-efficiency recuperator.

Thiers et al. [56,57] studied a wood-pellet-fueled SE micro-CHP unit

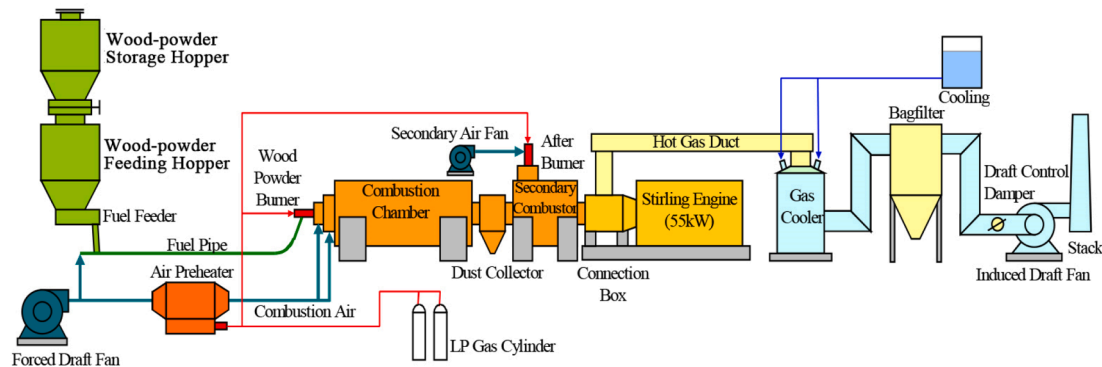

(a)



(b)

Fig. 7. (a) Configuration and (b) photograph of wood-powder-fueled SE small-scale CHP plant [52].

(manufactured by Sunmachine GmbH) to characterize its annual performance when integrated into a residential building. First, they performed an experimental test to characterize and model the performance of the micro-CHP unit in the steady and transient states. They then developed an integrated air and domestic water heating system model and coupled it to a building model through the COMFIE software. A sensitivity analysis indicated that the dimensioning of different components of the system (such as the volume of the thermal storage tank) had a strong influence on its thermal and electrical performances.

Cardozo et al. [58] experimented on a 20-kW_{th} wood-pellet burner coupled to a 1-kW_e gamma-type SE (developed by Genoastirling S.r.l. [59]), studying the impacts of pellet type, combustion-chamber length, and cycling operation. The results indicated that the temperature at the heater head of the SE was sensitive to the distance to the wood-pellet burner. In experiments, the overall system efficiency was maintained above 72%. Most recently, they compared the heater-head temperatures and CHP performance of the SE when using sugarcane bagasse and wood pellets as fuel [60]. It was concluded that bagasse and wood pellets gave similar SE heater-head temperatures, power outputs, and emission levels in the steady-state and transient states. Meanwhile, because of ash accumulation, the overall system efficiency with bagasse pellets was slightly lower than that with wood pellets.

For a fossil-fuel-powered Stirling micro-CHP system, the SE heater head is in direct contact with the combustion flame. The heater head is usually designed with a relatively narrow flue gas passage, and the heater tubes are mounted with fins for improved convective heat transfer. The purpose of this arrangement is to maximize heat transfer from the hot combustion gases to the internal working gas of the engine. However, when the fossil fuel is replaced by biomass, the narrow passages in the heater head are easily blocked by fouling (caused by aerosol formation and condensation of ash vapor when the flue gas is cooled) after a short period of operation [48,61]. Therefore, it is inadvisable to use an SE designed for natural gas in a biomass system. In regular designs of biomass-powered SEs, the biomass combustion takes place in fixed-bed systems and heat is recovered from the exhaust gases. Furthermore, the heater and air preheater of the SE are designed to minimize the likelihood of the exhaust-gas passages becoming blocked by particles and so that they are easy to clean. However, despite these measures, it is still difficult to prevent soot from depositing on the heat-exchanger surfaces, which reduces the system efficiency progressively [48,52]. To address this problem, the conventional solution is to keep the combustion-chamber temperature below the ash melting point by using an inert bulk gas that flows through the combustion chamber (this

is done by either (i) increasing the amount of excess air (i.e., increasing the excess air ratio) or (ii) recirculating the exhaust or combustion gas) to absorb some of the released heat and reduce the flame temperature in the combustion process [47]. However, reducing the combustion-chamber temperature sacrifices system efficiency accordingly.

Using fluidized-bed combustion is an innovative way to solve the ash-deposit issues in biomass-powered Stirling CHP systems. By using the advantages of fluidized beds (i.e., homogeneous temperature distribution, enlarged heat transfer in the bed material area, and fuel flexibility), Thring [62] in 1977 was the first to propose combining fluidized beds with SEs to enhance the heat transfer from fixed-bed combustion to the SE HHX. Later, Miccio et al. [63,64] developed an integrated SE–fluidized-bed experimental system that placed the heater of an SE in direct contact with the sand of a fluidized-bed combustor (FBC). By comparison with the SE gas-fired combustor configuration, it was concluded an SE with the biomass-fired fluidized-bed configuration could perform similarly to a catalytic gas burner. Subsequently, Urciuolo et al. [65] assessed experimentally the performances of a CHP unit consisting of an FBC and an SE, as shown in Fig. 8. The results indicated that the sensible heat associated with the fluidization gas should be recovered to increase the combined efficiency of the CHP system.

Angrisani et al. [66] proposed a unique approach to solve the ash-deposit issues by introducing a solar–biomass hybrid CHP system (as shown in Fig. 9). The system comprised (i) a Scheffler concentrator to capture and concentrate the solar radiation, (ii) a fluidized bed as a receiver of solar energy, (iii) a heat exchanger with the heater head of the SE, (iv) a biomass combustor, (v) an SE to convert the heat collected in the fluidized bed into mechanical and then electrical power, and (vi) a heat exchanger to recover residual heat for heating purposes. A model was developed to evaluate the performance of the proposed CHP system, and the results indicated that although such a system has some advantages, a high investment cost is the main drawback.

Also, in 2011 the Friedrich–Alexander University Erlangen–Nürnberg began developing a micro-scale CHP plant combining fluidized-bed combustion with an SE. They first constructed an experimental setup by linking a 3-kW_e Sunmachine SE with a 100-kW_{th} fluidized-bed combustor (the HHX of the SE was mounted directly in the bed area), and no ash deposits or fouling on the heat-exchanger surfaces were observed during tests [67]. Later, supported by the BioWasteStirling project, they developed a pilot plant that combined a 45-kW_{th} fluidized-bed combustor with a 5-kW_e alpha-configuration SE provided by Frauscher Thermal Motors [68]. When using wood pellets as fuel, an electrical efficiency of 13–15% and an overall efficiency of more than

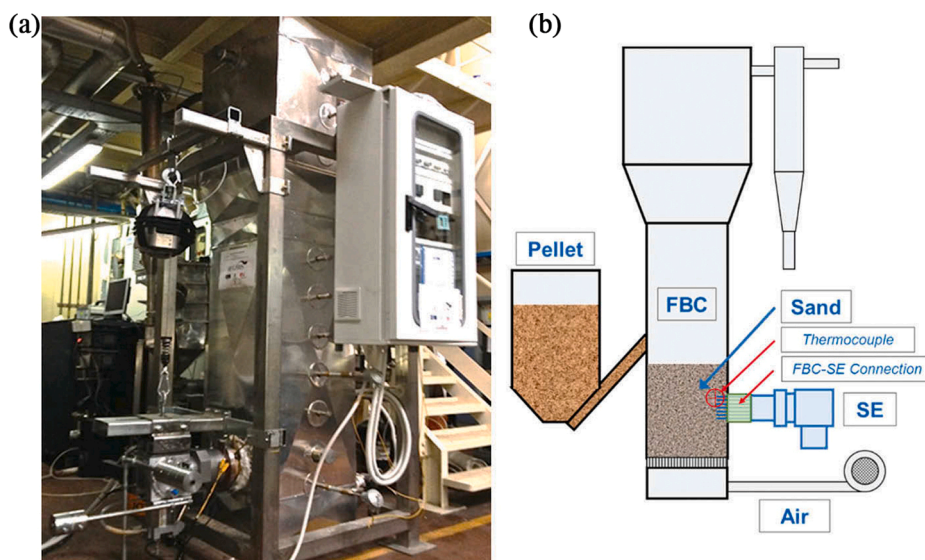

Fig. 8. (a) Experimental setup and (b) schematic of CHP unit built by Urciuolo et al. [65].

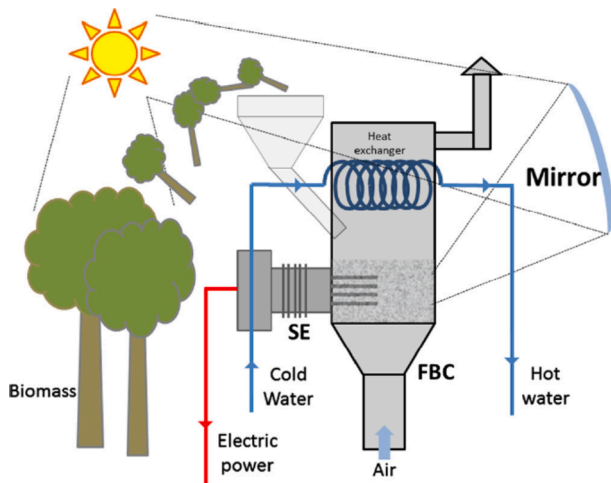

Fig. 9. Schematic of solar-biomass hybrid CHP system proposed by Angrisani et al. [66].

85% were achieved during laboratory tests. Furthermore, regarding operational requirements, the legal limits for CO and fine dust emissions were satisfied [44].

In summary, biomass-powered Stirling CHP systems constitute another research hotspot in SE-based CHP technology. However, this type of Stirling CHP system is currently at the demonstration stage, with only a few commercial units available. The main problem hindering the development of biomass-powered Stirling CHP systems is the fouling and slagging that occurs in the heat exchangers. Although some measures have been proposed to avoid or reduce ash deposits, the problem is yet to be solved fully, thereby meaning that biomass-powered Stirling CHP systems require regular cleaning and maintenance as essential measures.

3.3. Solar-powered Stirling CHP systems

As renewable energy, solar energy is among the cleanest and most abundant, and the concept of a solar-powered Stirling micro-CHP system has attracted increasing interest in recent years. Crema et al. [69] proposed and studied a novel modular solar-powered micro-CHP plant that can generate up to 3 kW of electrical power and 9 kW of thermal power by using parabolic trough collectors and an SE operating at moderate temperatures (around 300 °C). Nosek [70] proposed the concept of a hybrid solar-powered Stirling micro-CHP unit based on dish-Stirling technology; a computational model was developed to assess the annual performance of the proposed system, and the results showed that for a 10-kW_e hybrid solar-powered Stirling micro-CHP unit, the annual energy saving in solar operational mode was 50.38 MWh, which corresponds to 4800 m³ of natural gas considering a conventional gas furnace. Ferreira et al. [71] optimized a solar-powered SE with a parabolic dish concentrator for micro-CHP generation from the perspectives of thermodynamics and economics; the optimization resulted in a positive annual worth of 627€ per year for an optimal physical configuration of the micro-CHP system. Moghadam et al. [72] carried out a numerical study of using dish-Stirling micro-CHP plants for residential buildings in five cities of Iran; they evaluated the performance of the proposed system through energy, economic, and environmental (3E) analysis.

Although the concept of a solar-powered Stirling micro-CHP system has been proposed and many numerical investigations have been carried out, few such demonstration plants have been built and a complete experimental validation of the system's feasibility is lacking. This may be attributed to the immaturity and poor market penetration of dish-Stirling concentrated solar power technology.

3.4. Waste-gas-powered Stirling CHP systems

Waste gases from power plants and industrial processes could be used to actuate an SE-based CHP unit. Li et al. [73] developed a beta-type SE prototype with a rhombic drive mechanism. In tests, the exhaust gases from a gasoline engine were used to power the SE-based micro-CHP system, and a maximum output shaft power of 3476 W was obtained at a speed of 1248 rpm. Their work demonstrated that an SE powered by mid-to-high-temperature waste gases could achieve a considerable power level for engineering applications. Nevertheless, the reliability of this option is not well proven given that soot deposition will degrade the heat-transfer performance of the heater after a sufficient operating time.

3.5. CCHP systems based on Stirling engines

CCHP is an extension of CHP by using the exhausted heat to generate useful cooling power via a heat-driven cooling technology [74]. A typical SE-based CCHP system contains an SE CHP unit and an absorption chiller. Fig. 10 shows a schematic of an exemplary CCHP system with an SE. The generator of the absorption chiller absorbs part or all of the exhaust heat from the SE combustion gases as its driving force.

Kong et al. [75] calculated and compared the energy saving and economic benefits of a small-scale CCHP plant using an SE and a double-effect absorption chiller with those of a conventional system that provides cooling, heating, and power separately; the SE-based CCHP plant could achieve primary energy savings (PES) of more than 33% compared to conventional solutions, and the absorption chiller's thermal performance had a significant effect on the efficiency of the considered CCHP plant. Karami and Sayyadi [76] used 3E analysis to analyze and optimize an SE-based CCHP plant for small-scale residential applications in Iran considering four different climatic conditions; they concluded that the SE-based CCHP plant would be untenable in extremely hot and humid conditions. Kaldehi et al. [77] designed an alpha-type SE for a micro-CCHP plant; using electricity tracking, heat tracking, and overall efficiency to determine the SE size in different climate regions of Iran, the CCHP plant had an overall efficiency of 79–88%; also, an SE with a capacity of 2–6 kW gave the highest annual efficiency for all climate regions. Chahartaghi and Sheykhi [78] modeled a trigeneration system driven by two beta-type SEs and studied the impacts of the main operational and geometrical parameters of the engine; the model was validated using experimental data from a GPU-3 SE (Ground Power Unit developed by General Motors Research Labs for the U.S. Army in 1965), and the results indicated that the electrical and trigeneration efficiencies of their proposed trigeneration system were 27.3% and 74%, respectively. In other work [79], Chahartaghi and Sheykhi studied how the SE rotational speed affected the efficiency, exergy loss, fuel consumption, CO₂ emissions, and fuel costs of the CCHP system, and they estimated the payback period of the proposed system under different working conditions; the results showed that if the system was operated for around 6 h per day with average speeds, then the payback period would be less than three years. They also evaluated the proposed CCHP system with helium and hydrogen as working gases from energy, environmental, and economic perspectives [80].

Stirling CCHP systems powered by renewable resources and alternative fuels have also attracted increasing attention in recent years. Harrod et al. [81] studied how the performance of individual components affected the operational characteristics of a biomass-powered SE-based CCHP system for a small office building. From technological and economic perspectives, Huang et al. [82] assessed the viability of CCHP systems fueled by biofuels for households in remote areas; the results indicated that SE-based CCHP systems are suitable for households with a heat-to-electricity ratio of 3.0–3.4. Udeh et al. [83] performed a techno-economic assessment on a biomass fueled micro-CCHP system that hybridizes an SE and an ORC engine, and the results showed that hybridizing the SE with an ORC could enhance the performance of a

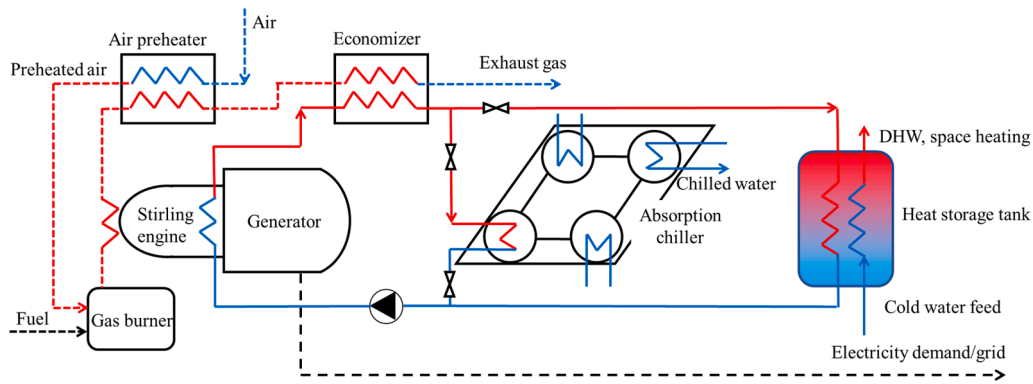

Fig. 10. Schematic of exemplary combined cooling, heating, and power (CCHP) system with an SE.

standalone SE and offer improved performance in a micro-CCHP configuration.

In summary, because of their current high investment costs and relatively low electrical efficiency under actual operating conditions, SE-based CCHP systems are still in the R&D phase, with none publicly reported demonstration plants and few operating experiences [84,85].

3.6. Commercially available Stirling-engine-based CHP systems

Fig. 11 shows statistical data for pre-2017 sales of micro-CHP units in Europe by technology. As can be seen, the European CHP market is dominated by ICEs and SEs, but the ratio of SEs sold to total annual sales is lower than that for ICEs because of the lower technical maturity of the former. Companies involved in micro-scale Stirling CHP include WhisperGen, Cleanergy (formerly SOLO), Microgen, Qnergy (formerly Infinia), and Inspirit Energy (formerly Disenco), while companies involved in small-scale Stirling CHP include Stirling DK and Stirling Biopower. In this section, we introduce SE-based CHP units that are currently available on the market, have appeared on the market in the past, or are close to market application in the near future.

3.6.1. Micro-scale Stirling CHP units

3.6.1.1. WhisperGen. Originating from the University of Canterbury in New Zealand, the WhisperGen micro-CHP unit produced by Whisper Tech was the first viable Stirling micro-CHP product [6]. Whisper Tech was a New Zealand firm that was committed to developing micro-CHP systems based on SEs for use in small-scale applications. The main micro-CHP products of Whisper Tech included the WhisperGen Stirling Mk4 and Mk5 systems. The engine used in the WhisperGen micro-CHP units was a four-cylinder alpha-type SE with a wobble-yoke drive mechanism. The reciprocating motion of the pistons was translated into

rotary motion with very low piston side loads via the drive mechanism. The rotary generator used in the WhisperGen micro-CHP unit was a single-phase induction generator with four poles. The main burner was of the premix surface type. The company especially used low-pressure nitrogen, a low heater head temperature, and a low-efficiency regenerator for the SE, aimed at reducing the investment cost and payback period and thus leading to a viable product. However, the electrical efficiency of the system was sacrificed accordingly: the on-site electrical efficiency was no more than 11%. As stated by Whisper Tech, the WhisperGen micro-CHP unit had a design life of 30 000 h [86].

As an early product of Whisper Tech, the WhisperGen Stirling Mk4 system had an electrical output of up to 1000 W, but the unit had no auxiliary burner and therefore could provide a maximum heat output of only 8 kW. A field trial that began in the Netherlands in 2005 found that comfort issues arose occasionally in houses equipped with a WhisperGen Stirling Mk4 unit [87], and those issues were attributed to two main factors: (i) the nominal heat output of the WhisperGen Stirling Mk4 unit was lower than those of conventional boilers; (ii) the SEs had to raise their heater head temperature first before they could output heat. To solve those issues, the WhisperGen Stirling Mk5 unit was equipped with a 7-kW_{th} supplementary burner with a premix surface type (as shown in Fig. 12) to boost the heat output [6]. The WhisperGen Stirling Mk5 unit could provide a heat output of up to 13–14 kW_{th}, making the unit capable of meeting larger heat demand and thus suitable for larger houses. In January 2008, a joint venture (Efficient Home Energy) was established by Whisper Tech and the Spanish Mondragón Corporación Cooperativa to mass-produce WhisperGen micro-CHP units for the European market. However, by the end of 2012 Efficient Home Energy had to file for bankruptcy because of financial problems, and WhisperGen is no longer available.

3.6.1.2. Cleanergy (formerly SOLO). SOLO Stirling GmbH started selling its SOLO V161 micro-CHP unit (Fig. 13) in the summer of 2004 and had sold 150 units by the end of 2006. The SE used in the SOLO V161 was based on a design by the Swedish company United Stirling and was an alpha-type SE with two cylinders in V-formation [89]. Helium was used as the working gas with a maximum cycle pressure of 15 MPa. The SE was coupled directly to a three-phase asynchronous generator that also started the SE, and the engine speed was around 1500 rpm. The SOLO V161 micro-CHP unit used natural gas or liquefied petroleum gas as fuel. In the unit, air was pre-heated and mixed with fuel to improve efficiency; a flameless oxidation (Flox®-Operation) burner was used that recirculated a proportion of the exhaust gases into the combustion process, thereby reducing the formation of NO₂ substantially. The SOLO V161 micro-CHP unit could generate 2–9 kW of electricity and 22–30 kW of thermal power with an electrical efficiency of 22–24% and an overall CHP efficiency of more than 90% [6,89]. Assembled on a frame with a sound-insulation hood, the unit had a total mass and size of 460 kg and 1.35 m × 0.7 m × 1.0 m (L × W × H), respectively. The micro-

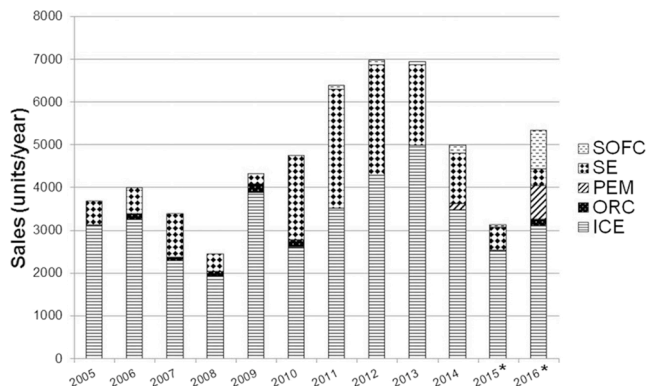

Fig. 11. European micro-CHP sales by technology (ORC: organic Rankine cycle) [5].

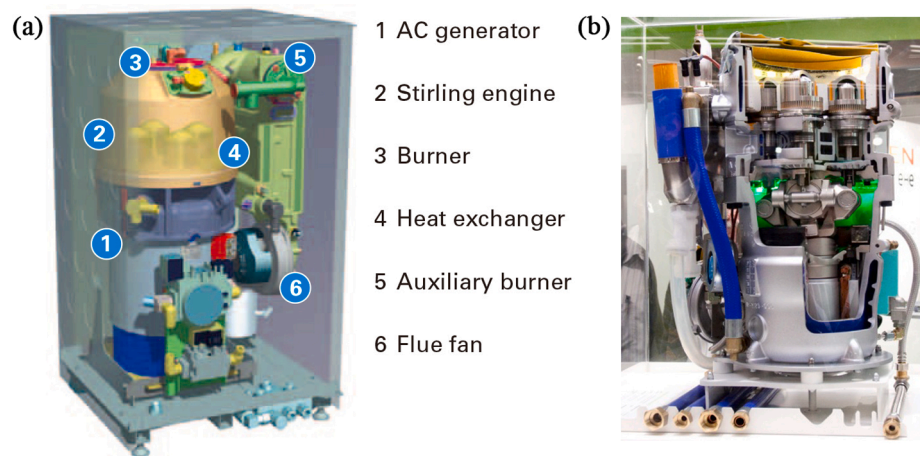

Fig. 12. Rendering image and photograph of WhisperGen Mk5 unit [18,88].

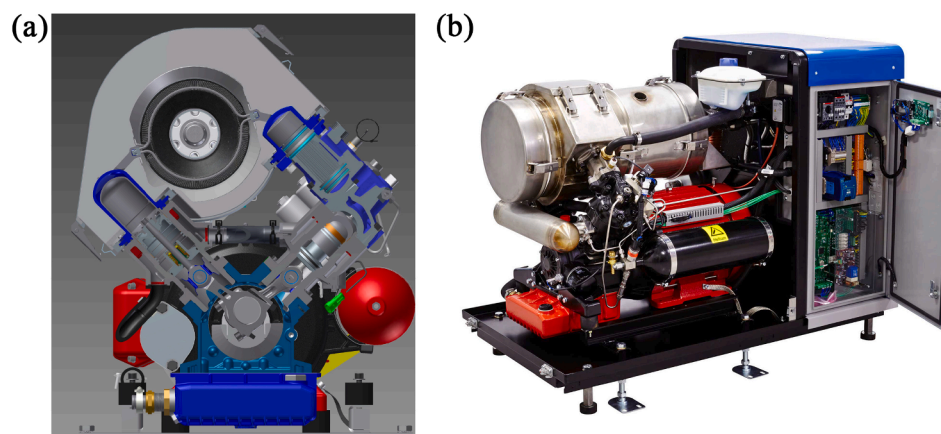

Fig. 13. (a) Section view and (b) photograph of SOLO V161 CHP-unit [91,92].

CHP unit required maintenance every 4000–6000 h because the piston rings had to be replaced [6].

Unfortunately, SOLO Stirling GmbH had to close in 2007 because of funding problems. The Swedish company Cleanergy AB obtained all rights and patents for the V161 SE from Solo Kleinmotoren GmbH in 2008, and in early summer 2018 Cleanergy changed the name of the company into Azelio [90].

3.6.1.3. Microgen. The UK company BG Group developed a wall-mountable CHP unit called the Microgen unit that was based on core FPSE technology from the US company Sunpower. Later, several home-appliance manufacturers including Remeha, Baxi, Senertec, Brötje, and Viessmann were expected to market their own micro-CHP units by integrating the Microgen unit. Trial versions of the Microgen unit's engines were produced in Japan in the early days, and mass manufacturing of the FPSEs was transferred to China in 2010 [6].

The Microgen unit used a beta-type FPSE with an integral linear alternator. It also contained a supplementary burner that enabled the unit to meet higher heat demand and thus was suitable even for larger houses. The unit could produce 1.1 kW of electricity and had a thermal output of 15–36 kW_{th} depending on the capacity of the supplementary burner. The field-trial electrical efficiency of the Microgen unit was around 13% and the overall efficiency was around 90%. Taking the micro-CHP Ecogen unit as an example (Fig. 14 shows a rendering image, a section view, and the SE of the micro-CHP Ecogen by Baxi), it is fueled by natural gas and comprises a ring-shaped main burner and a built-in SE. This micro-CHP unit can provide up to 24 kW_{th} of thermal power

with an auxiliary burner. The dimensions of the unit are 920 mm × 426 mm × 425 mm (H × W × D) and the total mass is 115 kg [93].

3.6.1.4. Qnergy (formerly Infinia). The Infinia Corporation (formerly known as the Stirling Technology Company) developed an FPSE for micro-CHP systems with power levels of 1–3 kW_e [95]. The 1-kW_e FPSE (refer to RG-1000) was incorporated in micro-CHP products manufactured by Ariston Thermo Group, Bosch Thermotechnik, Enatec in Europe, and Rinnai in Japan since 2000 [96,97]. Fig. 15(a) shows a photograph of the Ariston 1-kW_e SE-based micro-CHP unit. The unit integrates an FPSE, a supplementary burner, and a hot-water storage cylinder, with a total size of 600 mm × 600 mm × 1850 mm (L × W × H). The mass of the unit is 250 kg. The thermal output of the Ariston micro-CHP unit is 4–35 kW_{th}, and the CHP efficiency of the unit is higher than 98% in condensing mode [93].

In 2013, Infinia was acquired by Qnergy, which states that its latest commercial micro-CHP product the SmartBoiler Series [Fig. 15(b)] can produce an electrical power output of 2.8–7.2 kW with an electrical efficiency of 15.3%. At the same time, the system can provide up to 43 kW of thermal output with an overall CHP efficiency of 99%. The dimensions of the SmartBoiler are 834 mm × 680 mm × 1430 mm (L × W × H) and the mass is 295 kg [98].

3.6.1.5. Inspirit energy (formerly Disenco). Disenco's KSE technology originated from the core Swedish United Stirling technology that was developed subsequently by the Norwegian company Sigma Elektroteknisk [99]. Fig. 16(a) and (b) show the Sigma 3-kW_e SE and

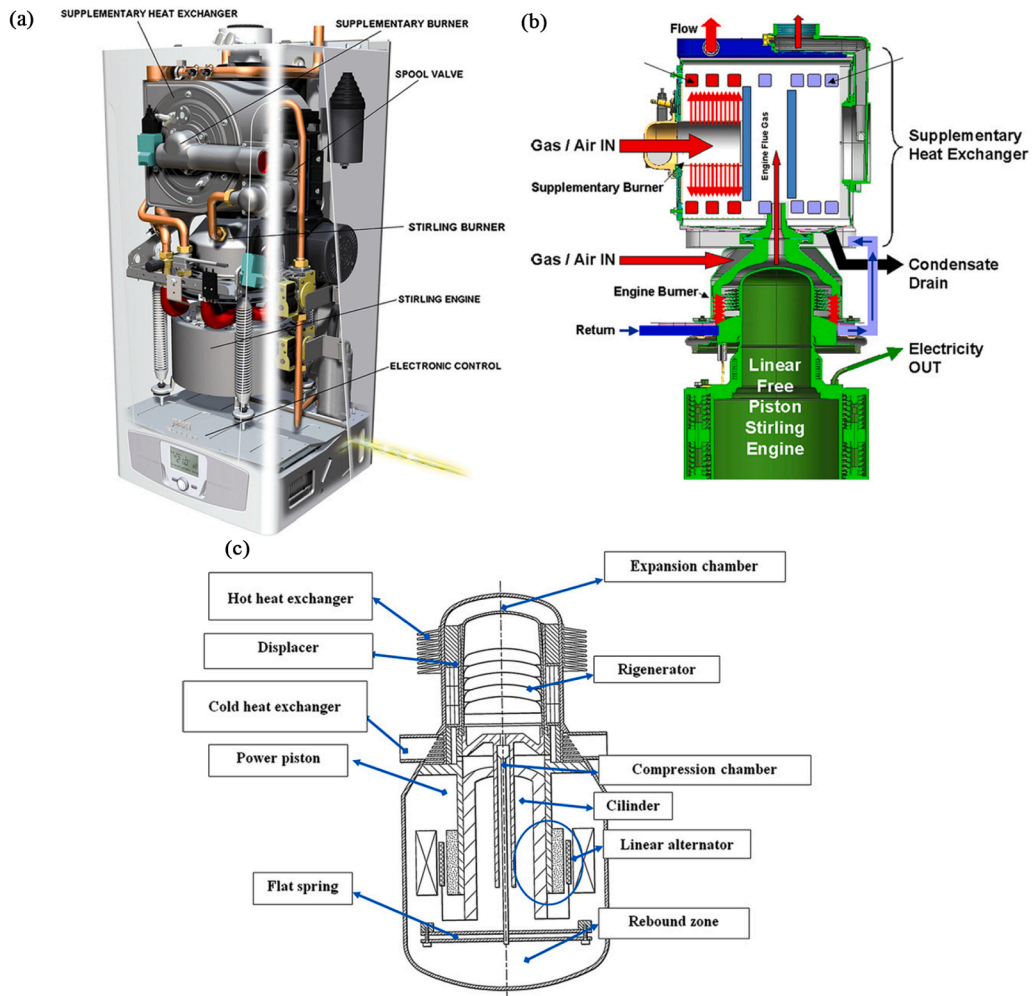

Fig. 14. (a) Rendering image, (b) section view, and (c) SE of micro-CHP Ecogen by Baxi [94].

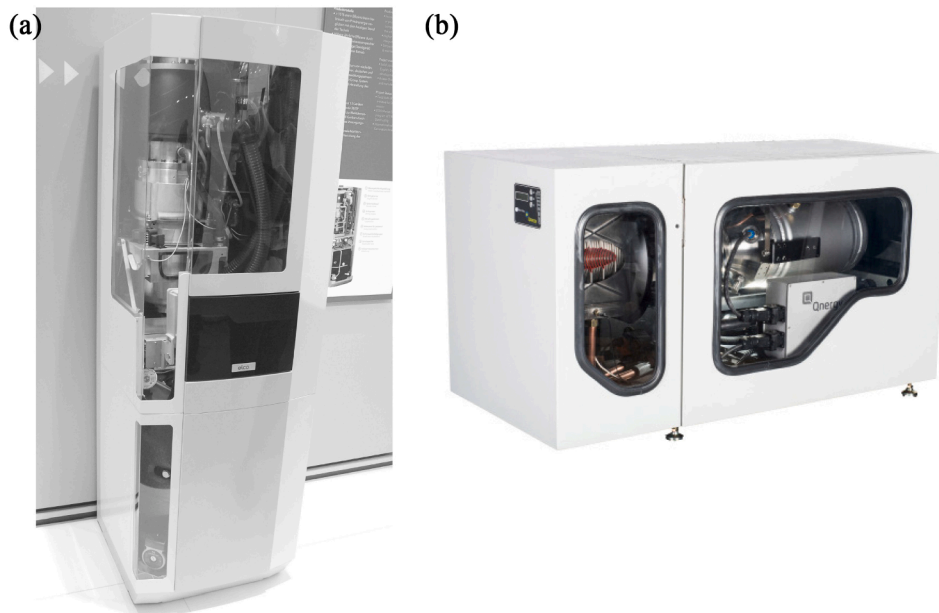

Fig. 15. Photographs of (a) Ariston 1-kW_e micro-CHP unit and (b) Qnergy micro-CHP unit [6,98].

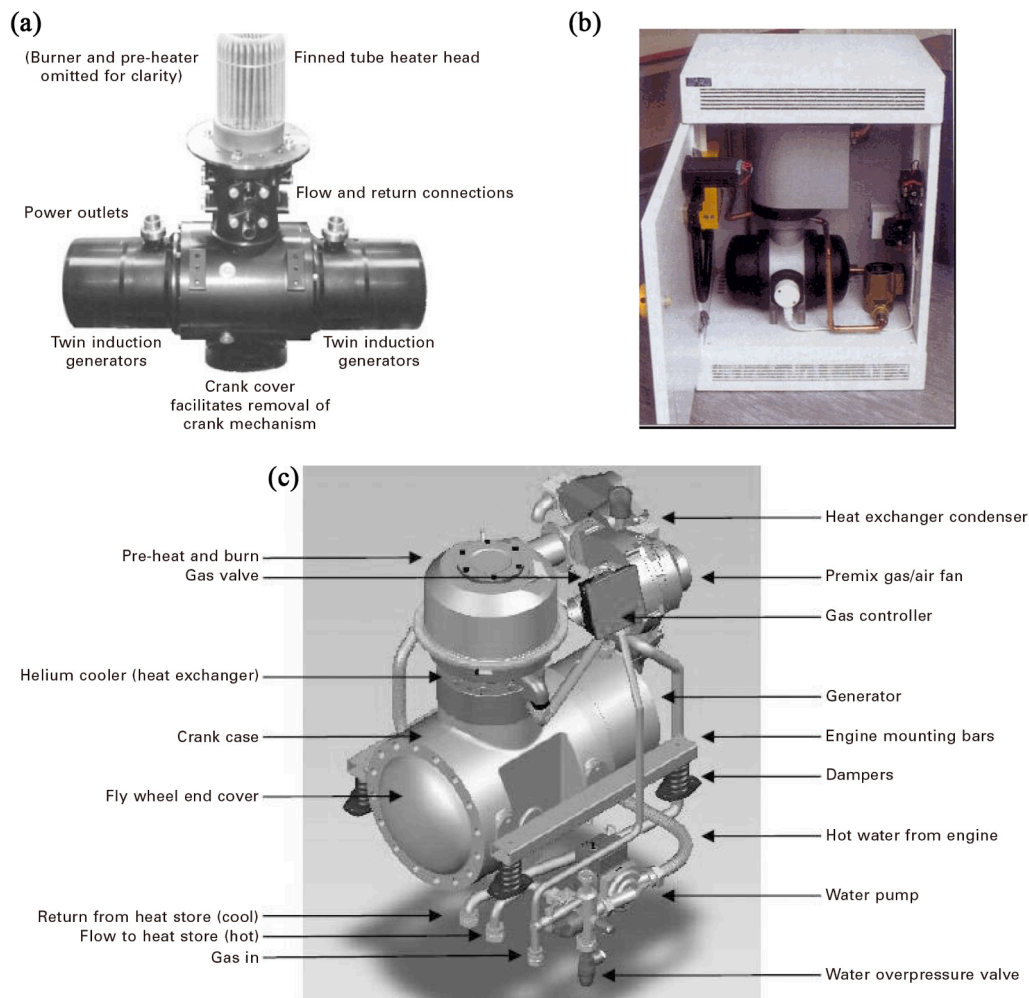

Fig. 16. (a) SE and (b) photograph of Sigma 3-kW_e micro-CHP unit, and (c) three-dimensional diagram of Disenco 3-kW_e micro-CHP [6,101,93].

corresponding micro-CHP unit, respectively. Its SE used an ingenious Carlqvist crank mechanism to convert reciprocating motion into rotary motion, thus driving two three-phase induction generators with a total of 3 kW_e of electrical power output. Both generators were incorporated in a helium-charged crankcase. The engine contained two-stage regenerators, an expensive finned-tube-type HHX, and an Inconel air preheater. These designs gave the system an electrical efficiency of more than 20% [6].

After the micro-CHP project was taken over by the British company Disenco, the latter redesigned the SE by replacing the original Carlqvist crank mechanism with a conventional rhombic-drive crank mechanism, and the engine performance was severely sacrificed accordingly. Fig. 16 (c) shows a schematic of Disenco's 3-kW_e micro-CHP appliance, which could provide an electrical power of 0.5–3 kW_e, a thermal power of 12–17.4 kW_{th}, an electrical efficiency of approximately 15%, and an overall efficiency of around 90% [93]. In 2010, the design of Disenco's 3-kW_e micro-CHP unit was taken over by Inspirit Energy [100]; this unit is currently still in development, and there have been no further reports on this product.

3.6.2. Small-scale Stirling CHP units

3.6.2.1. Stirling DK. As a spin-off from the Technical University of Denmark, Stirling DK is a market leader in biomass-compatible SE-based CHP systems. They offer a standard solution with one to four SEs with an electrical output of 35–140 kW_e, and each engine has a thermal output of 140 kW_{th}. As of 2014, 16 engines were installed throughout Europe

[102]. Fig. 17 shows a simplified process diagram and a photograph of the Stirling DK CHP plant. Fuel (such as wood chips) is fed into the top of an updraft gasifier that converts the fuel into product gases (a combustible mixture of gases) with a temperature of 70–80 °C through gasification reactions. The product gas is then led to a combustion chamber and combusted completely, generating temperatures of higher than 1200 °C. The hot flue gases transfer heat to the SE heater by radiation and convection, and the engine produces electricity and process heat accordingly. The flue gas then passes through a combustion air preheater, economizer, and a gasification air preheater in sequence, and the residual heat of the flue gas is used to heat the water in the economizer and preheat the air that is supplied to the gasifier as well as to the combustion chamber. However, because all Stirling DK CHP plants were essentially custom manufactured at their Danish factory, the economics of the company were so poor that it is no longer in business.

3.6.2.2. Stirling Biopower. Stirling Biopower is now providing an SE-based cogenerator named FleXgen G38 (Fig. 18), which is derived from Stirling Thermal Motors Power's PowerUnit product. The main component of the cogenerator is a four-cylinder SE with a swash-plate drive mechanism, which makes the output torque of the engine nearly constant. The working gas of the SE is hydrogen, so the cogenerator also includes a hydrogen replenishment system. The SE can generate up to 38 kW of electrical power at a speed of 1800 rpm, corresponding to an efficiency of up to 29%. A heat exchanger that can recover an additional thermal power of 65 kW_{th} coming from a hot gas stream leads to an overall efficiency up to 78% [104].

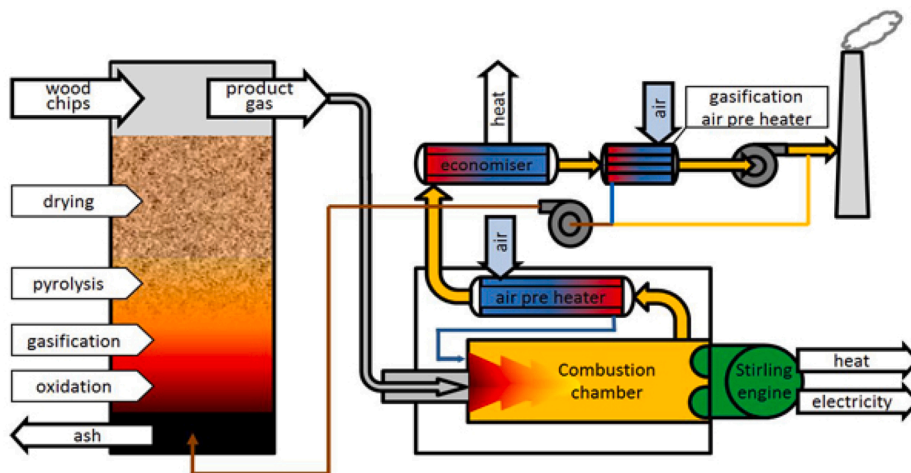

(a)



(b)

Fig. 17. (a) Simplified process diagram and (b) photograph of Stirling DK CHP plant [103].

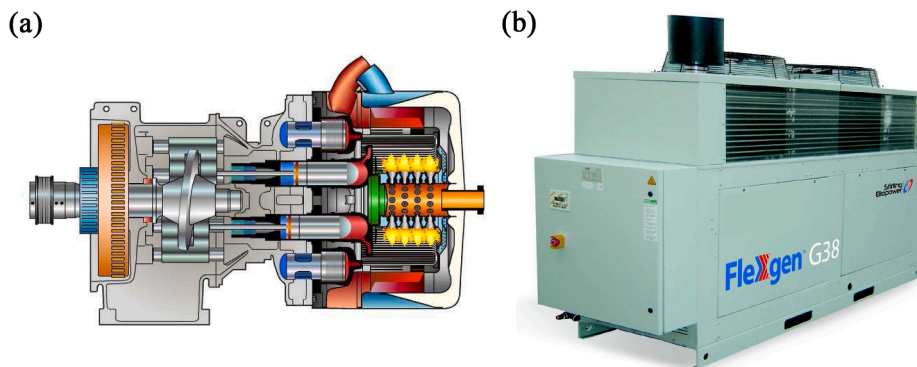

Fig. 18. (a) SE configuration and (b) photograph of FleXgen unit [104].

As given in Table 1, a panorama of the commercially available or reported SE-based CHP systems that can be found in the bibliography is conducive to a rational evaluation.

4. Characteristics of Stirling-engine-based CHP systems

In this section, we discuss the efficiency, cost, emissions, PES, and durability associated with SE-based CHP systems. It is essential to

Table 1
Summary of commercially available or reported SE-based CHP systems.

Year	Manufacturer/ author	Model	Engine type	Fuel	Working gas	Power		Efficiency			Notes	Level of development	Reference (s)
						P_{net} [kW _e]	Q_{gen} [kW _{th}]	$\eta_{electrical}$ [%]	$\eta_{thermal}$ [%]	$\eta_{combined}$ [%]			
2008	Cleanergy/SOLO	Stirling 161	Alpha-type KSE	Natural gas	He	9.0	26.0	25.0	72.2	97.2	Mass: 460 kg; size: 70 cm × 128 cm × 98 cm	Commercial product	[105–106]
Since 1993	Whisper Tech Ltd	WhisperGen SE	Alpha-type KSE	Natural gas	N ₂	1–1.2	7.5–14.5	12	77	89	Mass: 154 kg; size: 83.8 cm × 49.1 cm × 56.3 cm; noise: <46 dB	Commercial product*	[7]
Since 2010	Microgen™	–	FPSE	Natural gas	He	1.1	15–36	13	77	90	–	Commercial product	[7]
Since 2010	BAXI Ecogen	–	FPSE	Natural gas	He	1.0	6.0	13.5	81.1	94.6	Mass: 115 kg; size: 92 cm × 42.6 cm × 42.5 cm; noise: 45 dB, Microgen SE	Commercial product	[105,107]
Since 2010	Remeha eVita	eVita 25 s, 28c	FPSE	Natural gas	He	1	5	15.9	79.4	95.3	Microgen SE	Commercial product	[108]
Since 2010	Viessmann	Vitotwin 350-F, 300-W	FPSE	Natural gas	He	1	5.3	15.3	81.5	95.8	Microgen SE	Commercial product	[109]
Since 2010	Senertec	Dachs Stirling	FPSE	Natural gas	He	1	5.8	13.3	77.3	90.6	Microgen SE	Commercial product	[108]
2012	Disenco (Inspirit)	–	KSE	Natural gas	He	3	15	16	76	92	–	Commercial product	[7,110]
Since 2000	Enatec	–	FPSE	Natural gas	He	1	6.4	12.5	80	92.5	Infinia SE	–	[110]
Since 2008	Bosch Thermotechnik	–	FPSE	Natural gas	He	1	6.4	13	82	95	Infinia SE	Commercial product	[108]
2013	Qnergy	SmartBoiler Series	FPSE	Natural gas	He	2.8–7.2	43	15.3	–	99	Mass: 295 kg; size: 83.4 cm × 68 cm × 143 cm	Commercial product	[98]
2008	Shanghai MicroPowers Ltd.	4R90GZ	Alpha-type KSE	Natural gas	H ₂	50	90	28–32	–	greater than 85	Mass: 750 kg (engine); size: 214 cm × 135 cm × 167 cm; noise: <75 dB	Commercial product	[111]
2003	Stirling Danmark	–	Beta-type KSE	Biomass	He	31	272	9.2	80.8	90	–	Commercial product*	[48]
2007	Stirling Danmark	SM5A	Beta-type KSE	Natural gas, biogas	He	9	25	20–22	–	80–88	Mass: 390 kg; size: 76.2 cm × 137 cm × 108.5 cm (W × D × H)	Commercial product*	[112]
2004	Stirling Danmark	–	Beta-type KSE	Biomass	He	75	475	12	74	86	–	Commercial product*	[50]
2010	Stirling Biopower/ Qalovis	FleXgen G38	4-cylinder KSE	Wood chips, wood pellets	H ₂	38	65	29	–	78	–	Demonstration plant	[104]
Since 2005	Sunmachine	–	Alpha-type KSE	Wood pellets	N ₂	3.0	10.5	20.0	70.0	90.0	–	Commercial product*	[105]
2014	Genoastirling S.r.l./ Cardozo et al.	–	Gamma-type KSE	Wood pellets	N ₂	0.489	15	2.3	69.7	72	–	Lab test	[58]
2018	Zhu et al.	–	FPSE	Electrical heater	He	2.9	6.3	28	59.5	87.5	–	Lab test	[26]
2020	Park et al.	–	FPSE	Natural gas	He	0.96	2.75	23	65	88	–	Lab test	[24]

* No longer available

consider these characteristics because they (i) can be used to explain why Stirling-based CHP technology is suited to residential applications and (ii) have a direct impact on wider applications of this technology in the future.

4.1. Efficiencies

System efficiency is a key factor when selecting CHP technology, given that it determines the reduced amount of primary energy, emissions, and running cost as well as payback period. As described earlier, SE-based CHP systems can be fueled by natural gas, solar radiation, biomass fuel, and so on, thus the system electrical and thermal efficiencies vary depending on the fuel used. Also, the engine type, engine size, running model, and the recovered heat temperature play important roles in the cogeneration performance.

Currently, for natural-gas-fueled SE-based CHP units, the electrical efficiency is 10–35% and the CHP efficiency is above 85% with an electricity-to-heat ratio of around 0.3. In 2007, Thomas [112] used laboratory tests to evaluate the performances of two SE-based micro-CHP units, namely (i) the SOLO 161 micro-CHP unit manufactured by SOLO Stirling GmbH and (ii) the SM5A micro-CHP unit built by Stirling Denmark. Each unit was powered by natural gas during the test period. The test results indicated that when the return water temperature was kept constant at 30 °C, the electrical efficiency of the SOLO 161 micro-CHP unit remained above 24% with the supply water temperature increasing from 40 to 65 °C. However, the electrical efficiency of the CHP SM5A was marginally lower than that of the SOLO 161 micro-CHP unit because the former was designed for biogas. The overall efficiency of the SOLO 161 micro-CHP unit was above 96%, while that of the CHP SM5A was 80–88% within the studied supply water temperature limits. In 2008, Kuhn et al. [106] reviewed the results of some field tests on gas-fueled SE-based systems; the tested systems included SOLO 161 micro-CHP units installed in Berlin, Fürth, and Ditzingen–Hirschlanden in Germany and WhisperGen SE systems installed in France and the Netherlands. For the SOLO system, the results were encouraging; for example, in the Fürth field test, the system achieved a CHP efficiency of over 90%. For the WhisperGen system, however, the CHP performance failed to meet expectations in the Dutch test.

For biomass-fueled SE-based micro-CHP units, the reported electrical efficiencies were lower than those with natural gas because of the lower combustion temperature [44]. For example, Bierderman presented test results for a 35-kW_e biomass-powered SE-based CHP plant that achieved an electrical efficiency of 9.2% and an overall CHP efficiency of 90.0% [48]. Obara et al. [113] also reported results of power generation efficiencies of approximately 12% for a KSE with a maximum electrical power output of 1.5 kW_e, built for cold-region houses, and fueled with woody biomass.

It should be noted that the potential economics and environmental benefits of CHP are not exclusively technology-related, but they depend on how the full installation is designed or how the CHP plant is run and integrated within the energy system of the application. This means that not only must the performance of the SE be optimized in its own right, but that the auxiliary components in the SE-based CHP plant as well as its interaction with the energy system of the application be carefully considered. Therefore, in many cases, necessary to accept compromises in efficiency in order to achieve a robust and practical CHP system [6].

Fig. 19 summarizes the rated electrical efficiency and thermal efficiency versus rated electrical power for different CHP technologies. As can be seen, the electrical efficiency of SE-based CHP units is also highly dependent on the engine capacity, with larger-capacity units having higher electrical efficiencies. It is also interesting to note that for a given electrical power, the electrical efficiency of SE-based CHP technology is higher than that of micro Rankine cycle (MRC)-based and micro gas turbine (MGT)-based technologies and is close to that of ICE-based technology.

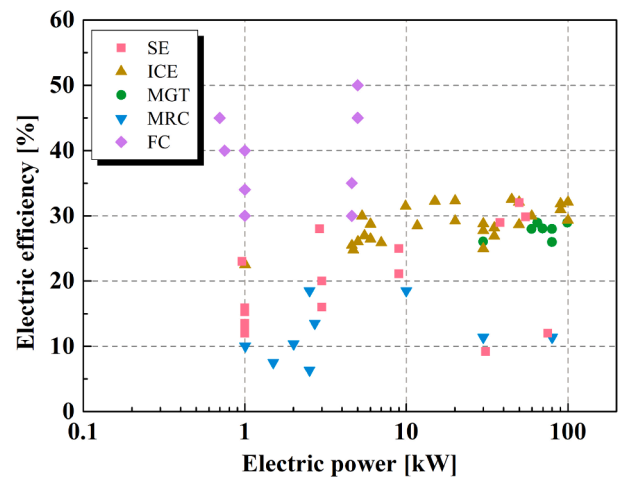

(a)

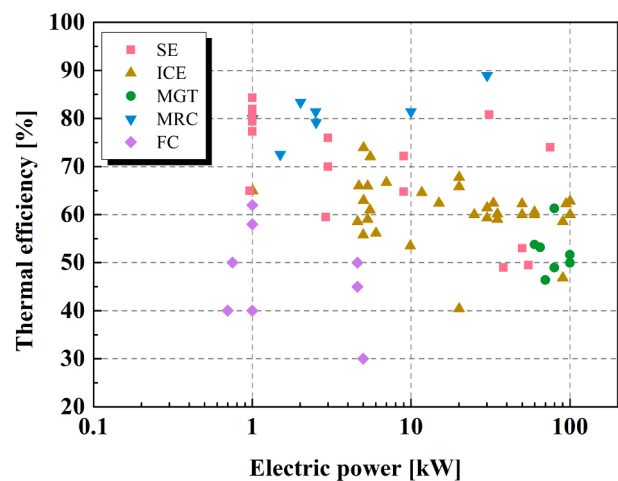

(b)

Fig. 19. (a) Rated electrical efficiency and (b) thermal efficiency versus electrical power (data from [16,114]).

4.2. Costs

Currently, the relatively high investment cost of SE-based CHP units is one of their main competitive weaknesses. There are no standard prices for SE-based CHP units because these units are at either the R&D or pre-commercial stage and mass production is lacking. Because of the higher engineering precision required, SE-based CHP units are expected to cost more than ICE-based units (but less than fuel-cell-based units). In 2012, Ferreira et al. [7] reported an investment cost for SE-based CHP units of 2800–10 000€/kW_e depending on the rated electrical power output, while for ICE-based units the cost was 2100–10 000€/kW_e. For comparison, in 2014 the investment cost for fuel-cell micro-CHP systems was higher than 20 000€/kW_e [115].

Taking the SOLO 161 micro-CHP unit as an example, in 2003 the total investment cost for the unit was around 24 900€ [116]. In 2005, the investment cost of the SOLO unit was still twice that of an ICE-based CHP unit with an identical capacity [117]. Meanwhile, the maintenance cost of 0.010€/kWh for an SE-based system was lower compared with that of 0.014€/kWh for an ICE-based system, with this attributed to the reduced mechanical wear suffered by SEs. As another commercially available SE-based micro-CHP unit, WhisperGen was the cheapest micro-CHP system available on the UK market in 2010; the installed cost was 6640–8860€ in the UK compared with 14 000€ in Germany

[118,119], which was apparently due to significant subsidies provided in the UK. Table 2 summarizes the investment costs of different commercial SE-based CHP system in Europe before 2015. Although the latest costs of SE-based CHP units could not be found in the public domain, it is anticipated that their prices will fall with time, technology improvement and increasing production volumes, thereby promoting greater market share.

4.3. Emissions

The level of exhaust gas emission has a strong impact on the emission-saving performance of SE-based CHP units, in which combustion takes place outside the engine, thereby making the combustion continuous rather than cyclic as in an ICE-based unit. This provides the benefits that (i) the combustion process is easily controlled and (ii) a very low emission level is reached easily without the need for an exhaust-gas after-treatment system as in ICEs. Therefore, the emissions from an SE-based CHP unit can be comparable with those from a condensing boiler and are estimated as being 10 times lower than those from ICE-based units as stated by Onovwiona et al. [123]. The prominent emissions in SE-based CHP units are NO_x and CO. Unburned hydrocarbon and particulate emissions from SE-based CHP units are negligible when compared with those from ICE-based units. Table 3 gives the reported emission levels of CO and NO_x for SE-based CHP units. As can be seen, the levels of emissions from SEs depend mainly on the fuel used and the engine size. Regarding carbon emissions, SE-based CHP units powered by renewable resources (e.g., biomass and solar) are considered largely emission-free or carbon-neutral emission sources, and so the installation of these types of unit may be increased to substitute non-renewable-powered units, with incentives that promote CO_2 reductions [124].

CHP systems can greatly reduce overall greenhouse gas (GHG) emissions, so here we discuss the CO_2 emission savings that SE-based CHP systems can achieve. An indicator known as the equivalent CO_2 avoided emission is introduced accordingly, which is used to compare the equivalent CO_2 emissions of an alternative system (i.e., an SE-based CHP system herein) with those of the conventional system (i.e., a system based on separate energy production). This indicator is defined as

$$\Delta\text{CO}_2 = \frac{\text{CO}_{2,\text{CS}} - \text{CO}_{2,\text{AS}}}{\text{CO}_{2,\text{CS}}}, \quad (5)$$

where $\text{CO}_{2,\text{CS}}$ and $\text{CO}_{2,\text{AS}}$ denote the equivalent CO_2 emissions of the conventional and alternative systems, respectively. A positive value of

Table 2

Summary of investment costs for different commercial SE-based CHP system in Europe.

Manufacturer & model	Rated electrical power output [kW _e]	Investment cost [€]	Year/country	Reference
SOLO 161 micro-CHP unit	9	24 900	2003/–	[116]
		25 000	2014/–	[120]
WhisperGen unit	1	6640–8860*	2010/UK	[119]
		14 000	2010/Germany	[119]
EcoGen WGS 20.1	1	8500	2014/–	[120]
		8160*	2012/UK	[121]
Remeha eVita	1	13 645	2014/–	[120]
		10 000	2010/Netherlands	[119]
Enerlyt 2- ZGM-1 kW	1	11 000	2011/Germany	[119]
		11 950	2014/–	[120]
		12 000	2014/–	[122]

*Minus subsidy.

Table 3

Emission levels for SE-based CHP units.

Model	Fuel	Electrical power output [kW]	NO_x [mg/Nm ³]	CO [mg/Nm ³]	Reference
WhisperGen	Natural gas	1	<100	<70	[120]
Remeha eVita	Natural gas	1	37	32	[120]
Enerlyt 2- ZGM-1 kW	Natural gas	1	133	12	[122]
EcoGen WGS 20.1	Natural gas	1	29.9	29.6	[120]
Stirling SOLO 161	Natural gas	9	105	191	[125]
Stirling Denmark SM5A	Natural gas/biogas	9	365	154	[125]
Chubu Electric Power Co. Inc. (STM Power engine)	Wood powder	55	180	14	[51]
Stirling Denmark 75-kW _e unit	Biomass	75	100	<10	[50]

ΔCO_2 indicates that the alternative system allows for a CO_2 emission saving in comparison to the conventional system.

A field trial carried out by the Carbon Trust [39] showed that if the offset emission from SE electrical generation was not taken into account, then SE micro-CHP systems achieved a carbon saving of around 5% per annum when compared with condensing boilers and grid electricity. While the specific annual CO_2 emission saving of a house is related to its annual heat demand, for a large house with an annual heat demand of approximately 20 000 kWh, the annual carbon saving is 200–700 kg per year. Therefore, the Carbon Trust suggested that the target market for SE micro-CHP systems should be households with high annual heat demands, such as large detached houses with four or more bedrooms. Meanwhile, Conroy et al. [126] showed that if the offset emission from SE electrical generation was taken into account, then an SE-based micro-CHP system could achieve an annual CO_2 emission saving of 1040 kg per annum, i.e., 16.1% less than the CO_2 emissions of condensing boilers and grid electricity. Roselli et al. [107] summarized the equivalent CO_2 avoided emissions of different CHP systems versus supplied electrical power in an Italian context, as shown in Fig. 20. As can be seen, SE-based micro-CHP systems allow for carbon savings of 15–35%, which is comparable to those of ICE-based micro-CHP systems. Furthermore, taking the Solo Stirling system as an example, the carbon savings are also highly dependent on the system load, and the closer the system operates to full load, the higher the carbon savings.

4.4. Primary energy savings

CHP systems can also greatly reduce primary energy consumption, and here we discuss the PES achievable with an SE-based CHP system. An indicator known as PES is introduced accordingly and is used to compare the primary energy consumed by an alternative system (i.e., an SE-based CHP system herein) with that of a conventional system (i.e., a system based on separate energy production) when supplying identical output. This indicator is defined as

$$\text{PES} = \frac{E_{\text{p,CS}} - E_{\text{p,AS}}}{E_{\text{p,CS}}}, \quad (6)$$

where $E_{\text{p,CS}}$ and $E_{\text{p,AS}}$ denote the primary energy consumed by the conventional and alternative systems, respectively. Likewise, a positive value of PES implies that the alternative system can achieve PES in comparison to the conventional system.

When estimating the PES capacity of a CHP system, the energy system within which it is deployed must be considered. Roselli et al. [107]

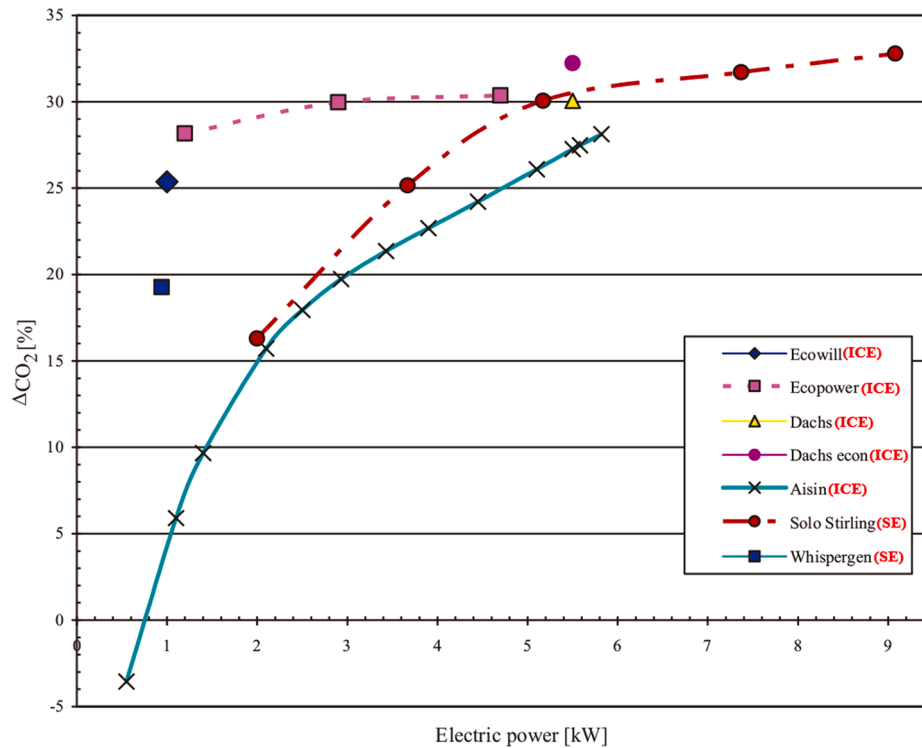

Fig. 20. ΔCO_2 of different CHP systems versus supplied electrical power in an Italian context [107].

summarized the PES of different CHP systems versus supplied electrical power in an Italian context, as shown in Fig. 21. As can be seen, the PES of SE-based micro-CHP systems is 10–27%, which is comparable to that of ICE-based micro-CHP systems.

4.5. Durability

Regarding the durability of SE-based CHP units, the completely sealed operating chambers of SEs result in low wear and long maintenance intervals. Furthermore, SEs avoid the need to service the limiting components used in ICEs, such as complex valving, timing gear, and spark ignition. Therefore, SE-based CHP units are expected to be more durable than ICE-based CHP units. Table 4 summarizes the service intervals and lifetimes for different SE-based CHP units.

A KSE requires oil for lubrication because of its crank mechanisms. To avoid oil migrating into the upper cylinder and contaminating and blocking the regenerator and reducing the engine performance, dry-lubricated piston rings made of self-lubricating materials were introduced; therefore, the piston rings must be replaced once the self-lubricating materials wear out. In addition, periodic maintenance for oil replacement and cleaning is indispensable. Onowwiona et al. [123] stated that the service interval for a KSE with a rated electrical power of <20 kW_e is 5000–8000 h, which is marginally longer than that of an ICE in the same range. In 2011, WhisperGen demonstrated that with essential maintenance, their SE-based micro-CHP units achieved a lifetime in excess of 20 000 h [6]. This agrees well with Jradi and Riffat [85], who noted that SE lifetimes are 10 000–30 000 h.

An FPSE has fewer moving parts than does a KSE, and the produced

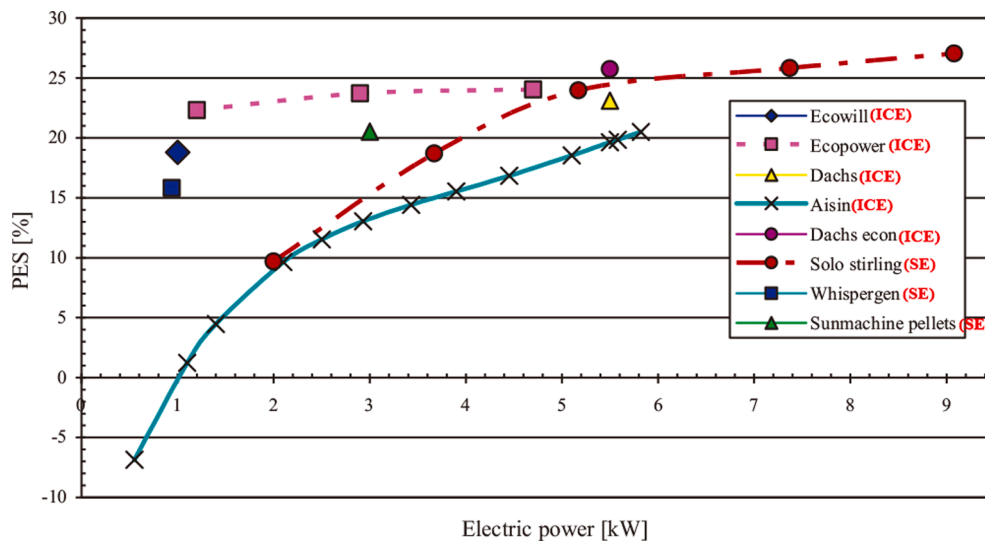

Fig. 21. Primary energy savings (PES) of different CHP systems versus supplied electrical power in an Italian context [107].

Table 4
Service intervals and lifetimes for different SE-based CHP units.

Model	Engine type	Electrical power output [kW _e]	Service interval [h]	Lifetime [h]	Reference
WhisperGen	KSE	1	4000	40 000	[120]
Remeha eVita	FPSE	1	8760	45 000–50 000	[120]
Enerlyt 2- ZGM-1 kW	KSE	1	6000	>100 000	[120]
EcoGen WGS 20.1	FPSE	1	–	50 000	[120]
Qnergy SmartBoiler	FPSE	7.2	–	>80 000	[127]
Stirling SOLO 161	KSE	9	5800	180 000	[120]

mechanical work is converted into electrical power via a linear alternator. The absence of a crank mechanism in an FPSE eliminates any side thrust exerted by the piston against the cylinder wall, and lubrication oil is no longer required, thereby avoiding the problem of regenerator contamination and blockage by the lubricant entering the working space. The flexure bearing suspension and wear-free clearance seal technology used in an FPSE increase its reliability and operating life substantially. In theory, an FPSE requires no maintenance because there is no mechanical contact or wear in the system. This has been demonstrated in an FPSE targeted for space applications, for which NASA achieved constant operation without maintenance for 12.55 y (110 000 h) [128]. We summarize here some information about the long-life capability of FPSEs: the design life of a Qnergy Corporation FPSE is estimated conservatively as 80 000 h with zero maintenance [127], and the design life of a Microgen FPSE is 50 000 h [129].

Although the lifetime, reliability, and durability of SEs—especially FPSEs—are encouraging, issues have arisen in reality with the currently immature designs, and lifetimes are yet to be verified widely; for example, in the Carbon Trust field trial, approximately 25% of the SE-based micro-CHP units that were installed suffered a fault or problem during their first year of operation [18]. Therefore, SE-based CHP units require substantial development to improve their reliability and durability prior to being introduced onto the market en masse.

5. Techno-economic assessment of Stirling-engine-based CHP systems

Techno-economic assessment of SE-based CHP systems is a way to evaluate their viability in comparison with the competing reference grid/boiler systems for residential energy supply. First, such assessment can help in understanding (i) the potential of SE-based CHP technology, (ii) the key market drivers, and (iii) the ability to meet policy aims. Second, one of the assessment purposes is to investigate the key technical parameters of SE-based CHP systems and thus understand how these parameters influence the economic and environmental credentials; this can inform the R&D focus of system developers. Finally, such assessment also helps policymakers to critique existing and potential new policies and regulations surrounding the promotion of SE-based CHP [130].

5.1. Building-integrated SE CHP modeling

The technical and economic feasibility of an SE-based CHP system depends greatly on (i) its design, size, and operating strategy, (ii) the energy system in which it is placed, (iii) electricity and fuel unit prices, and (iv) subsidy policies, among others. Therefore, an accurate and practical simulation model of SE-based CHP devices is indispensable for studying and evaluating the technical and economic feasibility of different SE-based CHP devices in different load environments [131]. In recent decades, many building-integrated SE-based micro-CHP models have been developed accordingly.

In the early days, much of the work in techno-economic assessment was based on a simplified performance-map method that decoupled the modeling of the SE CHP unit from that of the other parts of the building. The shortcoming of that approach was that it could not deal accurately

with the thermal coupling between the CHP unit and the building's heating, ventilation, and air conditioning system [131]. Subsequently, a combustion-based micro-CHP model (i.e., the Annex 42 model) suitable for use in whole-building simulation tools was developed within Annex 42 of the IEA/ECBCS program [132,133]. The Annex 42 model is a zero-order model that comprises three control volumes—namely energy conversion, thermal mass, and cooling water—and uses empirical correlations to characterize the energy flows into and out of these control volumes. Additionally, the model considers four main operating modes, namely stand-by, start-up, normal operating, and shut-down. Later, Lombardi et al. [131] improved the structure of the Annex 42 model based on extensive experimental data collected from an SE-based micro-CHP prototype unit.

As well as the Annex 42 model, some other models have been proposed to estimate the energy performance, environmental impact, and economics of SE micro-CHP systems. Conroy et al. [134] developed an energy performance model that could predict the fuel consumption, heat generation, and electrical power output of a WhisperGen SE micro-CHP Mk4 unit installed in household; based on empirical equations derived from measured performance data, the developed model was validated using field-trial data for a considered unit and was found to have satisfactory accuracy. Based on experimental investigations of a gas-fired SE micro-CHP system, Bouvenot et al. [110] developed a generic model of a micro-CHP system to assess its energy, environmental, and economic impacts; the modeling results were compared with experimental results and good accuracy was achieved, but the developed model was only compatible with gas applications and would need some improvements to be adapted for biomass-CHP. Ulloa et al. developed a one-dimensional dynamic model for an SE-based CHP system [135]; the developed model was validated on a commercial SE-based micro-CHP unit (model PPS16-24MD) manufactured by Whisper Tech, and it was concluded that it could be used to simulate a CHP system in the steady-state and transient states. In subsequent work [136], the dynamic model was improved and used to study the dynamic performance of a CHP unit under different mass flow inputs; a theoretical analysis was performed to assess the performance of the CHP unit with varying heat source temperature, and the simulation results showed that when the power-to-heat ratio was tracked for the heat or electricity demands of a dwelling, a significant fuel saving could be achieved.

5.2. Building-integrated SE CHP techno-economic assessment

With the aid of the developed building-integrated SE-based micro-CHP models, much techno-economic assessment work has been carried out, as summarized in Table 5. The Annex 42 model is the one used most widely in such work. Ribberink et al. [137] used it to assess the performance of an SE CHP unit in single detached houses in Ontario, Canada; the results indicated that switching from the best traditional system to a mature-technology SE micro-CHP unit would reduce emissions of both GHG (17%) and NO_x (3.6%) and would have a PES of 12% (assuming an efficiency of 32% for a coal-fired power plant). Alanne et al. [138] performed techno-economic assessment and optimization of SE-based micro-CHP systems for domestic applications; they explored optimal strategies for integrating SE-based micro-CHP systems in households, implementing the SE routine following the Annex 42 model.

Table 5
Summary of techno-economic assessments of SE-based CHP systems.

Authors/Reference	Year	Targeted country/region (s)	Evaluated SE CHP model	Reference systems	Targeted building type	Key assessment results
Ribberink et al. [137]	2009	Canada/Ontario	WhisperGen unit	Condensing hot air furnace and grid electricity	Single detached house	<ul style="list-style-type: none"> • 17% reduction of GHG emissions • 3.6% reduction of NO_x emissions • 12% primary energy savings (assuming 32% efficiency of coal-fired power plant)
Alanne et al. [138]	2010	Finland/Helsinki & Jyväskylä	WhisperGen unit	Condensing gas boiler and grid electricity	Two-floor single-family house	<ul style="list-style-type: none"> • 3–5% reduction in primary energy consumption and GHG emissions • Annual savings delivered when electricity and fuel prices are 0.05–0.15€/kWh
Alanne et al. [139]	2012	Finland/Helsinki & Jyväskylä	Solo Stirling 161	Pellet-fueled boiler and grid electricity	Two-floor single-family house	<ul style="list-style-type: none"> • 25% primary energy savings • 19% reduction of CO₂ emissions
González-Pino et al. [140]	2014	Spain	WhisperGen EU1™	Solar thermal panels, boiler, and grid electricity	New and retrofitted detached house	<ul style="list-style-type: none"> • SE micro-CHP units are not economically feasible in Spanish single-family dwellings • Decreasing SE micro-CHP unit's price could make it feasible in the coldest zones
Skorek-Osikowska et al. [142]	2017	Poland/southern part	Viessmann micro-CHP unit	Gas boiler and grid electricity (coal-fired power plant)	Detached house	<ul style="list-style-type: none"> • 5 t CO₂/year reduction of CO₂ emissions • The use of a heat storage system will create additional revenue
Magri et al. [94]	2012	Italy/Milan	Baxi Ecogen unit	Condensing gas boiler and grid electricity	Detached house	<ul style="list-style-type: none"> • 9.1% primary energy savings with same heat output • 9.1% reduction of CO₂ emissions

The computational results showed that an optimally operated micro-CHP configuration equipped with heat recovery and thermal storage would lead to a 3–5% reduction in primary energy consumption and CO₂ emissions in comparison with a hydronic heating system. Moreover, the suggested configuration was capable of annual monetary savings when electricity and fuel prices were 0.05–0.15€/kWh. In other work [139], they conducted a performance evaluation to assess the viability of wood-pellet-fueled SE-based micro-CHP systems when compared with plants based on either boilers or ground-source heat pumps in Finland; the dynamic effects of micro-CHP devices and the utilization of thermal exhaust via heat recovery were considered in their assessment. The results showed that using a district SE micro-CHP system achieved reductions of 25% in the annual consumption of primary energy and 19% in CO₂ emissions when compared to a pellet-fueled boiler. González-Pino et al. [140] analyzed the techno-economic feasibility of a Stirling micro-CHP unit to be integrated into residential buildings in different climatic conditions of Spain. Installing the micro-CHP unit was simulated using the TRNSYS 17 software, and the Annex 42 model was used to simulate the SE performance. Considering the Spanish regulations and economic framework, installing SE-based micro-CHP was not economically feasible in the three climatic zones studied. However, it was suggested that reducing the investment cost of the micro-CHP unit to a reasonable amount could make the SE-based micro-CHP units feasible in the coldest zones. In other work [141], they performed an economic analysis of a 1-kW_e SE-based micro-CHP plant (a WhisperGen EU1™ unit) for residential applications in the cold climatic zone of Spain. Dynamic models of both the micro-CHP unit and the reference installation (a condensing boiler supported by solar thermal panels) were implemented in the TRNSYS software to compare these solutions. It was concluded that promoting SE-based micro-CHP technology in Spain was not recommended at that time; this was because the initial investment was quite high and the amount of money recovered was extremely low. Besides, comparing results obtained from Spain and other countries such as Germany and the UK showed that the potential of micro-CHP in the latter countries was due to feed-in tariffs and support policies.

Skorek-Osikowska et al. [142] analyzed the capabilities and potential of using an SE-based micro-CHP system in a representative residential building in Poland. Based on Schmidt analysis, they developed a numerical model that could identify the basic parameters of the SE and determine the achievable efficiencies and power characteristics, they used a Viessmann micro-CHP unit (Vitolwin 300-W, comprising an FPSE and a condensing gas boiler) for the calculations. The results showed

that the SE-based micro-CHP unit could fulfill the demand of single-family houses for heat and electricity throughout the year, and using a heat storage system would generate additional revenue. Magri et al. [94] analyzed the energetic and economic performances of a natural-gas-fired SE-based micro-CHP unit (Baxi Ecogen) installed in a detached house in Milan, Italy in comparison with those of a gas condensing boiler. To carry out the evaluation, they used the TRNSYS software to build a dynamic model that comprised the building and the heating system. The results showed that the PES and financial saving with the micro-CHP unit were higher than those with a conventional gas condensing boiler. In addition to residential buildings, the techno-economic feasibilities of using SE CHP units to generate heat and electricity for a coal mine [143], a sailing boat [144], and a commercial caravan [145] have been evaluated, and promising results have been obtained in each potential application scenario.

5.3. Life-cycle assessment

The above techno-economic assessments were concentrated mainly on the direct emissions and cost reductions that could be realized by reduced electricity and gas consumption when switching from traditional systems to SE micro-CHP. However, those studies excluded the life-cycle impacts associated with the manufacturing, installation, and decommissioning of the SE micro-CHP unit. In response to this shortcoming, Stamford et al. [121] estimated the life-cycle environmental and economic implications of an SE-based micro-CHP system for household energy supply and compared it with conventional solutions (i.e., condensing boiler and grid electricity). The full life cycle of the micro-CHP unit was taken into account during the assessment, and the study was performed in a UK context. It was concluded that SE-based micro-CHP systems could achieve significant environmental and cost savings under highly efficient operating conditions compared to conventional solutions. However, considering their low on-site operational efficiencies in practice, the life-cycle environmental and economic performance of SE-based micro-CHP systems is likely to be inferior to that of conventional solutions. Consequently, Stamford et al. concluded that it was difficult to defend subsidies such as the feed-in-tariff for SE-based micro-CHP units.

In summary, the results of techno-economic assessments show that SE-based micro-CHP systems can create substantial PES and CO₂ emission reductions, leading to reduced annual operational costs. While the specific benefits differ among countries and climate regions, the results

of techno-economic assessments show that technology developers must increase the on-site operational efficiencies and reduce the costs of SE-based micro-CHP systems substantially to increase their viability when compared with the competing reference systems for residential energy supply.

6. Challenges and future trends

Although SE-based CHP technology is a feasible and promising technological option for domestic and small commercial applications, and despite the fact that much work has been done on prototype development, field trials, commercialization, and techno-economic assessments of different types of SE-based CHP unit, some key issues remain unsolved. Further work on these issues is recommended to integrate this technology effectively and promote its wider and more-effective use in domestic buildings.

6.1. Increase on-site electrical efficiency

According to most field-trial results for commercially available products, the electrical efficiency of SE-based CHP units is below expectation [121]. The reason for this is that manufacturers sacrifice electrical efficiency to reduce investment costs [6], but electrical efficiency is a key index when assessing the techno-economic worth of this technology. Therefore, much work is required to increase the electrical efficiency of SE-based CHP units without increasing their investment costs excessively.

That work will include (i) increasing the combustion efficiency of the combustion system by optimizing the burner design [146,147], (ii) enhancing the heat transfer between the combustion gas and heater head by improving the heater head design [148], (iii) exploring new regenerator materials and novel regenerator configurations to maximize heat transfer while minimizing flow losses [149], (iv) using advanced modeling approaches to optimize the engine design [150,151], and (v) increasing the generator efficiency by optimizing the generator design [152,153], and so on.

In addition, many of the thermal and flow losses that occur in an SE are related to the limitations in traditional manufacturing approaches, and those losses could be alleviated by using additive manufacturing techniques. For example, in the conventional process used to manufacture the SE heater head assembly, the components are connected and sealed by using brazing or welding, thereby making it difficult for the size and fit tolerance of the manufactured flow channels to meet the design requirements [154]. This causes unexpected design mutations of the heater head assembly and introduces additional thermal and flow losses. If an integrated heater head assembly could be produced through additive manufacturing, then good control of the gap size between components would be easily achieved and smooth flow paths between the heat exchangers and regenerator would be ensured, thereby reducing the thermal and flow losses and increasing the engine efficiency accordingly.

6.2. Reduce capital costs

Currently, the relatively high capital cost of SE-based CHP units is the main obstacle to widespread installation. First, most SE-based CHP units nowadays are essentially customized, resulting in poor economics. However, the cost will plummet with mass production, with need incentives and subsidy policies surrounding the promotion of SE-based CHP units from specific countries. Second, much SE manufacturing currently involves a lot of manual labor, and there is yet to be investment in cutting-edge manufacturing technologies such as additive manufacturing, automatic assembly, and industrial robots to reduce the production cost. Finally, the materials used for key parts are currently far from being cost effective, but the silver lining is that developments in material science in other fields (e.g., low-cost high-temperature

superalloys in aviation; regenerator materials in gas treatment; wear-resistant self-lubricating materials in bearings) will help to reduce the costs of SE-based CHP units to some extent. It should be noted that SE is thriving in some fields that are not pretty sensitive to the cost, such as air independent submarine propulsion systems, and on-board power systems for deep-space missions.

Most of the cost of an SE-based CHP unit is due to its SE. For a KSE, the high capital cost is due mainly to the heat exchangers (including the heater head, regenerator, and AHX), which account for nearly 40% of the total cost of the SE [155]. In addition, the piston-cylinder assembly, generator, and helium are also costly, and the considerable maintenance cost of a KSE-based CHP unit is also not negligible in the long term. For an FPSE, the high capital cost is due mainly to the heat exchangers, piston-cylinder assembly, permanent magnet, and demanding controller.

The SE heater head must withstand high temperatures and pressures during operation. This means that the heater-head material must be a good conductor and have high creep resistance and tensile strength at high temperatures. High-temperature superalloys such as Inconel 718 are excellent candidates for use in the SE heater head, but this material is very expensive. Therefore, finding a low-cost alternative that can meet the demanding heater-head requirements is essential for reducing the capital cost.

In addition to the heater head, the regenerator is also an important and costly part of an SE. Currently, SE regenerators are usually made of woven screens or random fibers [154,156]. Woven-screen regenerators have relatively high flow friction because of the tortuous gas path, and the cost and labor involved in assembling such regenerators are substantial and may be prohibitive for mass production. Although random-fiber regenerators are easy to fabricate and inexpensive, they have higher flow friction and lower effectiveness compared with foil regenerators. To date, foil regenerators are ideal because they have the highest possible figure of merit. However, wrapped-foil regenerators are difficult to produce with traditional manufacturing means because of the difficulty in maintaining the required uniform spacing between the wrapped-foil layers. It is anticipated that additive manufacturing could be used to manufacture a robust foil regenerator with high reliability and excellent performance [25].

The sealing mechanism between piston and cylinder is a common but crucial issue in KSEs. Currently, the trend is to use dry-friction piston rings to replace lubricated ones in the KSE sealing mechanism [91]. Therefore, actively exploring novel wear-resistant self-lubricating materials for piston rings will extend the maintenance interval of KSEs and thus reduce the maintenance cost. For FPSEs, the costs of the permanent magnet and controller could be lowered by optimizing the linear generator design and developing advanced control strategies, respectively.

6.3. Develop FPSE-based CHP systems

As addressed in Section 2, compared with conventional KSEs, the advantages of FPSEs are obviously attractive. Although FPSEs have begun to show good market penetration in the field of micro-CHP and have been shown to be highly compatible with micro-scale CHP systems over the past two decades, they still lag somewhat behind KSEs, especially in the field of small-scale CHP. Therefore, more attention should be paid to FPSEs and FPSE-based CHP systems to increase their technical maturity. Improving the reliability of FPSEs and developing high-power ones (with an electrical capacity higher than 15 kW_e) are subjects of further development.

6.4. Powered by renewable energy sources

Electricity sectors are being decarbonized worldwide and their environmental impacts are being reduced, thereby degrading the comparative performance of fossil-fuel-powered SE-based CHP systems

[41]. If SE-based micro- and small-scale CHP units are fueled by renewable resources (e.g., solar and biofuel), then the advantage of distributed generation would be enhanced accordingly, providing an important cut in pollutant emissions for the building sector. Furthermore, for households in rural locations without grid electricity, SE-based CHP units powered by renewable energy sources could ensure a safe, reliable, affordable, and sustainable supply of heat and electricity.

However, most biomass-powered Stirling CHP systems are faced with ash-deposit issues caused by the low ash melting temperatures of solid biomass fuel. Using fluidized-bed combustion is a promising approach to solve this issue and is a subject of further development. Meanwhile, to develop solar-powered Stirling CHP systems, the first priority is to develop an efficient low-cost solar concentrating collector that can store thermal energy.

7. Conclusions

A detailed review has been presented of the technological aspects and operating characteristics of SE CHP, as well as an evaluation of the state of commercial development and techno-economic issues. Challenges have been presented and future work has been recommended to facilitate the diffusion of SE-based CHP technology.

SEs are very attractive prime-mover technology for CHP applications because of their low emissions, maintenance, noise, and vibration, their theoretically high thermal-to-electrical efficiency, and their flexibility of fuel sources. However, although the past two decades have seen SE-based CHP systems begin to show good penetration into the residential market and become commercially available in a few developed countries, some challenges remain concerning technical, economic, and regulatory issues before such systems can enter the market en masse. Some of the main obstacles to be overcome are high manufacturing costs, long payback periods, and low on-site operational efficiencies, especially the electrical efficiency, together with the lack of incentives and support policies for residential CHP systems. Furthermore, against the background of grid decarbonization and carbon neutrality, the recommendation is to develop free-piston SE-based CHP systems and ones powered by renewable energy sources.

Declaration of Competing Interest

The authors declare that they have no known competing financial interests or personal relationships that could have appeared to influence the work reported in this paper.

Acknowledgments

This work was funded by the National Key Research and Development Program of China [grant numbers 2016YFB0901403 and 2016YFE0102200], the National Natural Science Foundation of China [grant number 51876214], and the UK–China Joint Research and Innovation Partnership Fund Ph.D. Placement Program [grant number 201804910919]. The authors would like to thank all the sponsors.

References

- [1] Gul MS, Patidar S. Understanding the energy consumption and occupancy of a multi-purpose academic building. *Energy Build* 2015;87:155–65.
- [2] J. Knowles.1 - Overview of small and micro combined heat and power (CHP) systems. In: Small and micro combined heat and power (CHP) systems. Advanced design, performance, materials and applications. A volume in Woodhead Publishing Series in Energy; 2011. p. 3–16.
- [3] M Peht, M Cames, C Fischer, B Prateorius, L Schneider, K Schumacher, et al. Micro cogeneration towards decentralized energy systems Springer, Berlin; 2006. p. 1–16.
- [4] Murugan S, Horák B. A review of micro combined heat and power systems for residential applications. *Renew Sustain Energy Rev* 2016;64:144–62.
- [5] Martínez S, Michaux G, Salagnac P, Bouvier JL. Micro-combined heat and power systems (micro-CHP) based on renewable energy sources. *Energy Convers Manage* 2017;154:262–85.
- [6] Harrison J. 8 - Stirling engine systems for small and micro combined heat and power (CHP) applications. In: Small and micro combined heat and power (CHP) systems. Advanced design, performance, materials and applications. A volume in Woodhead Publishing Series in Energy; 2011. p. 179–205.
- [7] Ferreira ACM, Nunes ML, Martins LASB. A review of Stirling engine technologies applied to micro-cogeneration systems. In: Proceedings of ECOS 2012, Perugia, Italy; 2012. p. 338–99.
- [8] Thombare DG, Verma SK. Technological development in the Stirling cycle engines. *Renew Sustain Energy Rev* 2008;12(1):1–38.
- [9] Walker G. Stirling engines. Oxford: Clarendon Press; 1980.
- [10] Swift GW. Thermoacoustics: A unifying perspective for some engines and refrigerators. Acoustical Society of America; 2002.
- [11] Luo E. Ideal thermodynamic processes of oscillatory-flow regenerative engines will go to ideal Stirling cycle? *AIP Conf Proc* 2012;1434(1):1883–90.
- [12] Wang K, Sanders SR, Dubey S, Choo FH, Duan F. Stirling cycle engines for recovering low and moderate temperature heat: a review. *Renew Sustain Energy Rev* 2016;62:89–108.
- [13] Zhu S, Yu G, Ma Y, Cheng Y, Wang Y, Yu S, et al. A free-piston Stirling generator integrated with a parabolic trough collector for thermal-to-electric conversion of solar energy. *Appl Energy* 2019;242:1248–58.
- [14] Walker G, Senft JR. Free piston Stirling engines. Berlin: Springer-Verlag; 1985.
- [15] Kongtragool B, Wongwiset S. A review of solar-powered Stirling engines and low temperature differential Stirling engines. *Renew Sustain Energy Rev* 2003;7(2): 131–54.
- [16] Vollrad Kuhn M, Pascale AD, Spina PR. Guidelines for residential micro-CHP systems design. *Appl Energy* 2012;97:673–85.
- [17] González-Pino I, Pérez-Iribarren E, Campos-Celador A, Terés-Zubiaga J. Analysis of the integration of micro-cogeneration units in space heating and domestic hot water plants. *Energy* 2020;200:117584.
- [18] Carbon Trust, November. Micro-CHP Accelerator: Interim Report; 2007.
- [19] Uchman W, Kotowicz J, Li KF. Evaluation of a micro-cogeneration unit with integrated electrical energy storage for residential application. *Appl Energy* 2021; 282:116196.
- [20] Balcombe P, Rigby D, Azapagic A. Energy self-sufficiency, grid demand variability and consumer costs: integrating solar PV, Stirling engine CHP and battery storage. *Appl Energy* 2015;155:393–408.
- [21] Auñón-Hidalgo JA, Sidrach-de-Cardona M, Auñón-Rodríguez F. Performance and CO2 emissions assessment of a novel combined solar photovoltaic and thermal, with a Stirling engine micro-CHP system for domestic environments. *Energy Convers Manage* 2021;230:113793.
- [22] Thorsen JE, Bovin J, Carlsen H. 3 kW Stirling engine for power and heat production. In: Proceedings of the international energy conversion engineering conference vol. 2; 1996. p. 1289–94.
- [23] Carlsen H, Bovin J. Test of 9 kW Stirling engine using biogas as fuel. In: Proceedings of the 10th international Stirling engine conference; 2001. p. 278–85.
- [24] Park J, Ko J, Kim H, Hong Y, Yeom H, Park S, et al. The design and experimental testing of a kW-class free-piston Stirling engine (FPSE) for micro-combined heat and power (m-CHP) applications. *Appl Therm Eng* 2020;164:114504.
- [25] Qiu S, Gao Y, Rinker G. Development of an advanced free-piston Stirling engine for micro combined heating and power application. *Appl Energy* 2019;235: 987–1000.
- [26] Zhu S, Yu G, Jongmin O, Xu T, Wu Z, Dai W, et al. Modeling and experimental investigation of a free-piston Stirling engine-based micro-combined heat and power system. *Appl Energy* 2018;226:522–33.
- [27] Wilcox Jr DA. The design, construction, and experimental evaluation of a compact thermoacoustic-stirling engine generator for use in a micro-CHP appliance. The Pennsylvania State University; 2017.
- [28] Aliabadi AA, Thomson MJ, Wallace JS, Tzanetakis T, Lamont W, Di Carlo J. Efficiency and emissions measurement of a Stirling-engine-based residential microcogeneration system run on diesel and biodiesel. *Energy Fuels* 2009;23(2): 1032–9.
- [29] Nicolas F. Efficiency and emissions study of a residential micro-cogeneration system based on a Stirling engine and fuelled by diesel and ethanol. University of Toronto; 2010.
- [30] Farra N, Tzanetakis T, Thomson MJ. Experimental determination of the efficiency and emissions of a residential microcogeneration system based on a Stirling engine and fuelled by diesel and ethanol. *Energy Fuels* 2012;26(2):889–900.
- [31] Rogdakis ED, Antonakos GD, Koronaki IP. Thermodynamic analysis and experimental investigation of a Solo V161 Stirling cogeneration unit. *Energy* 2012;45(1):503–11.
- [32] Urieli I, Berchowitz DM. Stirling cycle engine analysis. Bristol. England: Adam Hilger; 1984.
- [33] Valenti G, Silva P, Fergnani N, Campanari S, Ravidà A, Di Marcoberardino G, et al. Experimental and numerical study of a micro-cogeneration Stirling unit under diverse conditions of the working fluid. *Appl Energy* 2015;160:920–9.
- [34] Valenti G, Campanari S, Silva P, Ravidà A, Macchi E, Bischì A. On-off cyclic testing of a micro-cogeneration Stirling unit. *Energy Procedia* 2015;75:1197–201.
- [35] Remiorz L, Kotowicz J, Uchman W. Comparative assessment of the effectiveness of a free-piston Stirling engine-based micro-cogeneration unit and a heat pump. *Energy* 2018;148:134–47.
- [36] Entchev E, Gusdorf J, Swinton M, Bell M, Szadkowski F, Kalbfleisch W, et al. Micro-generation technology assessment for housing technology. *Energy Build* 2004;36(9):925–31.
- [37] Natural Resources Canada/Natural Research Council, Development of micro-combined heat and power technology assessment capability at the Canadian Center for Housing Technologies, Final Report; 2003.

- [38] Bell M, Swinton M, Entchev E, et al. Testing residential combined heat and power systems at the Canadian centre for housing technology. In: Proceedings, 2004 ACEEE summer study on energy efficiency in buildings. Washington, DC: American Council for an Energy-Efficient Economy; 2004.
- [39] Guy R, Sykes B. Carbon trust: micro-CHP accelerator. Final Report –2011; 2011. <http://www.networkrevolution.co.uk/>.
- [40] Jones O, Wardle R, Matthews PC. Micro-CHP trial report.
- [41] Lipp J. Field test with Stirling engine micro-combined heat and power units in residential buildings. *Proc Inst Mech Eng A: J Power Energy* 2012;227(1):43–52.
- [42] Dong L, Liu H, Riffat S. Development of small-scale and micro-scale biomass-fuelled CHP systems—A literature review. *Appl Therm Eng* 2009;29:2119–26.
- [43] Schneider T, Müller D, Karl J. A review of thermochemical biomass conversion combined with Stirling engines for the small-scale cogeneration of heat and power. *Renew Sustain Energy Rev* 2020;134:110288.
- [44] Carlsen H, Ammundsen N, Traerup J. 40 kW Stirling engine for solid fuel. In: Proceedings of the 31st intersociety energy conversion engineering conference, vol. 2; 1996. p. 1301–6.
- [45] Jensen N, Werling J, Carlsen Henrik, Henriksen Ulrik Birk. CHP from updraft gasifier and Stirling engine. In: 12th European biomass conference. ETA-Florence & WIP-Munich; 2002.
- [46] Pålsson M, Carlsen H. Development of a wood powder fuelled 35 kW Stirling CHP unit. In: Proceedings of the 11th ISEC (international Stirling engine conference); 2003. p. 221–30.
- [47] Biedermann F, Carlsen H, Schöch M, Obernberger I. Operating experiences with a small-scale CHP pilot plant based on a 35 kWel hermetic four cylinder Stirling engine for biomass fuels. In: Proceedings of the 11th ISEC (international Stirling engine conference); 2003. p. 248–54.
- [48] CISA, COSEA. The Ecological Plant in Castel d'Aiano—The CHP System of Castel d'Aiano School Campus: Wood Chips Gasification and Stirling Engine. Available online: http://www.centrocisa.it/materiale/pubblicazioni/CasteldAiano_inglese.pdf.
- [49] Biedermann F, Carlsen H, Obernberger I, Schöch M. Small-scale CHP plant based on a 75 kWel hermetic eight cylinder Stirling engine for biomass fuels—development, technology and operating experiences. In: 2nd world conference and exhibition on biomass for energy, industry and climate protection; 2004. p. 7–10.
- [50] Nishiyama A, Shimojima H, Ishikawa A, Itaya Y, Kambara S, Moritomi H, et al. Fuel and emissions properties of Stirling engine operated with wood powder. *Fuel* 2007;86(15):2333–42.
- [51] Sato K, Ohiwa N, Ishikawa A, Shimojima H, Nishiyama A, Moriya Y. Development of small-scale CHP plant with a wood powder-fueled Stirling engine. *J Power Energy Syst* 2008;2(5):1221–31.
- [52] Lane NW, Beale WT. A biomass-fired 1KW Stirling engine generator and its applications in South Africa. In: The 9th international Stirling engine conference, South Africa; 1999. p. 1–7.
- [53] Damirchi H, Najafi G, Alizadehnia S, Mamat R, Azwadi CS, Azmi WH, et al. Micro combined heat and power to provide heat and electrical power using biomass and Gamma-type Stirling engine. *Appl Therm Eng* 2016;103:1460–9.
- [54] Renzi M, Brandoni C. Study and application of a regenerative Stirling cogeneration device based on biomass combustion. *Appl Therm Eng* 2014;67: 341–51.
- [55] Thiers S, Aoun B, Peupartier B. Experimental characterization, modeling and simulation of a wood pellet micro-combined heat and power unit used as a heat source for a residential building. *Energy Build* 2010;42(6):896–903.
- [56] Aoun B, Thiers S, Peupartier B. Experimental characterization of a micro CHP unit based on Stirling engine, fueled by Wood Pellet. Proceedings of the 14th ISEC (international Stirling engine conference). 2009.
- [57] Cardozo E, Erlich C, Malmquist A, Alejo L. Integration of a wood pellet burner and a Stirling engine to produce residential heat and power. *Appl Therm Eng* 2014;73(1):671–80. <http://www.genoastirling.com>.
- [58] Cardozo E, Malmquist A. Performance comparison between the use of wood and sugarcane bagasse pellets in a Stirling engine micro-CHP system. *Appl Therm Eng* 2019;159:113945.
- [59] Kuosa M, Kaikko J, Koskelainen L. The impact of heat exchanger fouling on the optimum operation and maintenance of the Stirling engine. *Appl Therm Eng* 2007;27(10):1671–6.
- [60] Thring RH. Fluidised bed combustion for the Stirling engine. *Int J Heat Mass Tran* 1977;20(9):911–8.
- [61] Miccio F. On the integration between fluidized bed and Stirling engine for micro-generation. *Appl Therm Eng* 2013;52(1):46–53.
- [62] Marra FS, Miccio F, Solimene R, Urciuolo M, Chirone R, Continillo G, et al. Setup of an integrated Stirling Engine-Fluidized Bed (SE-FB) experimental system. In: Proceedings of the 16th ISEC (international Stirling engine conference); 2014. p. 24–6.
- [63] Urciuolo M, Chirone R, Saverio Marra F, Solimene R. Power generation by Stirling engine during fluidized bed combustion of wood pellets. *Combust Sci Technol* 2019;191(2):263–74.
- [64] Angrisani G, Bizon K, Chirone R, Continillo G, Fusco G, Lombardi S, et al. Development of a new concept solar-biomass cogeneration system. *Energy Convers Manage* 2013;75:552–60.
- [65] Müller D, Karl J. Biomass CHP with micro-fluidized bed combustion. In: 21st Eur biomass conf exhib; 2013. p. 147–50.
- [66] Schneider T, Müller D, Karl J. Biomass conversion with a fluidized bed-fired Stirling engine in a micro-scale chp plant. In: 26th Eur biomass conf exhib proc; 2018. p. 630–4.
- [67] Crema L, Alberti F, Wackelgard E, et al. Novel system for distributed energy generation from a small scale concentrated solar power. *Energy Procedia* 2014; 57:447–56.
- [68] Nosek Š. Hybrid Stirling Solar Engine Micro-Cogeneration Unit simulation for given localities of the Czech Republic; 2008.
- [69] Ferreira AC, Nunes ML, Teixeira JCF, Martins LA, Teixeira SF. Thermodynamic and economic optimization of a solar-powered Stirling engine for micro-cogeneration purposes. *Energy* 2016;111:1–17.
- [70] Moghadam RS, Sayyaadi H, Hosseinzade H. Sizing a solar dish Stirling micro-CHP system for residential application in diverse climatic conditions based on 3E analysis. *Energy Convers Manage* 2013;75:348–65.
- [71] Li T, Tang D, Li Z, Du J, Zhou T, Jia Y. Development and test of a Stirling engine driven by waste gases for the micro-CHP system. *Appl Therm Eng* 2012;33: 119–23.
- [72] Wu DW, Wang RZ. Combined cooling, heating and power: A review. *Prog Energy Combust Sci* 2006;32:459–95.
- [73] Kong XQ, Wang RZ, Huang XH. Energy efficiency and economic feasibility of CCHP driven by Stirling engine. *Energy Convers Manage* 2004;45(9–10): 1433–42.
- [74] Karami R, Sayyaadi H. Optimal sizing of Stirling-CCHP systems for residential buildings at diverse climatic conditions. *Appl Therm Eng* 2015;89:377–93.
- [75] Kaldehi BJ, Keshavarz A, Safaei Pirooz AA, Batooei A, Ebrahimi M. Designing a micro Stirling engine for cleaner production of combined cooling heating and power in residential sector of different climates. *J Clean Prod* 2017;154:502–16.
- [76] Chahartaghi M, Sheykhi M. Thermal modeling of a trigeneration system based on beta-type Stirling engine for reductions of fuel consumption and pollutant emission. *J Clean Prod* 2018;205:145–62.
- [77] Sheykhi M, Chahartaghi M, Balakheili MM, Kharkeshi BA, Miri SM. Energy, exergy, environmental, and economic modeling of combined cooling, heating and power system with Stirling engine and absorption chiller. *Energy Convers Manage* 2019;180:183–95.
- [78] Chahartaghi M, Sheykhi M. Energy, environmental and economic evaluations of a CCHP system driven by Stirling engine with helium and hydrogen as working gases. *Energy* 2019;174:1251–66.
- [79] Harrod J, Mago PJ, Luck R. Sizing analysis of a combined cooling, heating, and power system for a small office building using a wood waste biomass-fired Stirling engine. *Int J Energy Res* 2012;36(1):64–74.
- [80] Huang Y, Wang YD, Chen H, Zhang X, Mondol J, Shah N, et al. Performance analysis of biofuel fired trigeneration systems with energy storage for remote households. *Appl Energy* 2017;186:530–8.
- [81] Udeh GT, Michailos S, Ingham D, Hughes KJ, Ma L, Pourkashanian M. A techno-economic assessment of a biomass fuelled micro-CCHP driven by a hybrid Stirling and ORC engine. *Energy Convers Manage* 2021;227:113601.
- [82] Maraver D, Sin A, Royo J, et al. Assessment of CCHP systems based on biomass combustion for small-scale applications through a review of the technology and analysis of energy efficiency parameters. *Appl Energy* 2013;102:1303–13.
- [83] Jradi M, Riffat S. Tri-generation systems: Energy policies, prime movers, cooling technologies, configurations and operation strategies. *Renew Sustain Energy Rev* 2014;32:396–415.
- [84] Don Lucas. Design and Manufacturing Strategy for the WhisperGen micro Combined Heat and Power System. <https://ir.canterbury.ac.nz/bitstream/handle/10092/13572/MAD%20WhisperGen%20Presentation.pptx?sequence=2&isAllowed=y>.
- [85] Turckstra JW, Bartholomeus PMG, Overdiep HH. The gasunie smart distributed power systems program. 23rd World Gas Conference. 2006. www.BHKW-forum.info.
- [86] Öberg R, Olsson F, Pålsson M. Demonstration Stirling engine based micro-CHP with ultra-low emissions. *Svenskt gastekniskt center*; 2004.
- [87] <https://www.azelio.com/>.
- [88] Baumüller A, Borrás FX, Eskilson P, Nilson M, Verner A. Upgrading of Stirling engine dynamic seals – Swedish development since 40 years. Proceedings of the 17th ISEC (international Stirling engine conference). 2016. <http://www.stirling-energie.de/>.
- [89] Mahkamov K. 18- Thermal-engine-based small and micro combined heat and power (CHP) systems for domestic applications: modelling micro-CHP deployment. In: Small and micro combined heat and power (CHP) systems. Advanced design, performance, materials and applications. A volume in Woodhead Publishing Series in Energy; 2011. p. 179–205.
- [90] Magri G, Di Perna C, Serenelli G. Analysis of electric and thermal seasonal performances of a residential microCHP unit. *Appl Therm Eng* 2012;36:193–201.
- [91] Qiu S, Redinger D, Augenblick J. The new generation infinia free-piston Stirling engine for micro-CHP and remote power applications. In: 3rd international energy conversion engineering conference; 2005 (p. 5517).
- [92] Guido De Sanctis. Ariston CHP activities. <https://refman.energytransitionmodel.com/publications/1234/download>.
- [93] Van der Woude R, ten Haaken E, Zutt S, Vriesema B, Beckers G, BV AV. Intermediate results of the Enatec micro cogeneration system field trials. In: Proceedings of the international Stirling forum; 2004. <https://www.qnergy.com/wp-content/uploads/2018/01/Download-the-SmartB-oiler-Brochure-Spec-Sheet.pdf>.
- [94] Stirling Engine Assessment, EPRI, Palo Alto, CA; 2002. 1007317. <http://www.inspirit-energy.com/>.
- [95] http://www.microchap.info/sigma_3kwe_stirling_engine.htm.
- [96] Preto F. Evaluation of commercially available small scale biomass electrical generation technologies appropriate to the Yukon; 2014. http://www.energy.gov.yk.ca/pdf/yukon_chp_evaluation_report_final_march_29_2014.pdf.

- [103] Stirling DK Introduction; 2012. <https://docplayer.net/26885216-Stirling-dk-introduction-march-2012.html>.
- [104] <http://www.biowkk.eu/wp-content/uploads/2015/02/12748858113-Qalovis-Shrieves-Flexgen.pdf>.
- [105] Angrisani G, Roselli C, Sasso M. Distributed micro trigeneration systems. *Prog Energy Combust Sci* 2012;38:502–21.
- [106] Kuhn V, Klemes J, Bulatov I. MicroCHP: overview of selected technologies, products and field test results. *Appl Therm Eng* 2008;28(16):2039–48.
- [107] Roselli C, Sasso M, Sibilio S, Tzschentschler P. Experimental analysis of microgenerators based on different prime movers. *Energy Build* 2011;43(4):796–804.
- [108] González-Pino I. Modelling, experimental characterization and simulation of Stirling engine-based micro-cogeneration plants for residential buildings Universidad del País Vasco - Euskal Herriko Unibertsitatea; 2019. http://viessmann.com.ua/images/uploads/pdfs/Vitotwin_Micro_CHP_units.pdf.
- [109] Bouvenot JB, Andlauer B, Stabat P, Marchio D, Flament B, Latour B, et al. Gas Stirling engine μ CHP boiler experimental data driven model for building energy simulation. *Energy Build* 2014;84:117–31.
- [110] http://www.micropowers.com/en/generator_detail.aspx?cid=416&id=53.
- [111] Thomas B. Benchmark testing of Micro-CHP units. *Appl Therm Eng* 2008;28(16):2049–54.
- [112] Obara SY, Kito S, Hoshi A, Sasaki S. Study on woody biomass Stirling cycle for cold region houses. *Int J Energy Res* 2009;33:152–63.
- [113] Angrisani G, Roselli C, Sasso M. Distributed microtrigeneration systems. *Prog Energy Combust Sci* 2012;38(4):502–21.
- [114] Elmer T, Worall M, Wu S, Riffat SB. Fuel cell technology for domestic built environment applications: state of-the-art review. *Renew Sustain Energy Rev* 2015;42:913–31.
- [115] Pehnt M, Cames M, Fischer C, Praetorius B, Schneider L, Schumacher K. Micro cogeneration: towards decentralized energy systems; 2006.
- [116] Knight I, Ugursal I, Beausoleil-Morrison I. Residential cogeneration systems: A review of the current technologies. A report of Subtask A of FC+ COGENSIM. The simulation of building-integrated fuel cell and other cogeneration systems. In: Annex 42 of the international energy agency. Energy conservation in buildings and community systems programme; 2005. p. 1–93.
- [117] Staffell I, Baker P, Barton JP, Bergman N, Blanchard R, Brandon NP, et al. Part II: technology overviews. *Proc ICE - Energy* 2010;163:143–65. http://www.microchap.info/stirling_engine.htm.
- [118] Ferreira ACM. Numerical optimization and economic analysis in the design of a micro-CHP system with a Stirling engine and a solar collector. University of Minho; 2014.
- [119] Stamford L, Greening B, Azapagic A. Life cycle environmental and economic sustainability of Stirling engine micro-CHP systems. *Energy Technol* 2018;6(6):1119–38. http://www.enerlyt.de/pdf/flyer_2ZGM_06122019.pdf.
- [120] Onowwiona HI, Ugursal VI. Residential cogeneration systems: review of the current technology. *Renew Sustain Energy Rev* 2006;10(5):389–431.
- [121] Araoz Ramos JA. Thermodynamic analysis of Stirling engine systems: applications for combined heat and power. KTH-The Royal Institute of Technology; 2015. <https://www.buildup.eu/sites/default/files/content/Study%20on%20Micro%20CHPs.pdf>.
- [122] Conroy G, Duffy A, Ayompe LM. Economic, energy and GHG emissions performance evaluation of a WhisperGen Mk IV Stirling engine μ -CHP unit in a domestic dwelling. *Energy Convers Manage* 2014;81:465–74. <http://www.redhawkenergy.net/pdf/Brochures/Qnergy%20Stirling%20Engine.pdf>.
- [123] <https://ntrs.nasa.gov/archive/nasa/casi.ntrs.nasa.gov/20190002153.pdf>.
- [124] <https://www.microgen-engine.com/engines/>.
- [125] AD Hawkes 2-Techno-economic assessment of small and micro combined heat and power (CHP) systems. In: Small and micro combined heat and power (CHP) systems. Advanced design, performance, materials and applications. A volume in Woodhead Publishing Series in Energy; 2011. p. 17–41.
- [126] Lombardi K, Ugursal VI, Beausoleil-Morrison I. Proposed improvements to a model for characterizing the electrical and thermal energy performance of Stirling engine micro-cogeneration devices based upon experimental observations. *Appl Energy* 2010;87(10):3271–82.
- [127] Kelly N, Beausoleil-Morrison I. Specifications for modelling fuel cell and combustion-based residential cogeneration devices within whole-building simulation programs. IEA/ECBCS Annex 42 report; 2007. ISBN No. 978-0-662-47116-5.
- [128] Ferguson A, Kelly N, Weber A, et al. Modelling residential-scale combustion-based cogeneration in building simulation. *J Build Perform Simul* 2009;2(1):1–14.
- [129] Conroy G, Duffy A, Ayompe LM. Validated dynamic energy model for a Stirling engine μ -CHP unit using field trial data from a domestic dwelling. *Energy Build* 2013;62:18–26.
- [130] Ulloa C, Míguez J, Porteiro J, Eguía P, Cacabelos A. Development of a transient model of a Stirling-based CHP system. *Energies* 2013;6(7):3115–33.
- [131] Cacabelos A, Eguía P, Míguez JL, Rey G, Arce ME. Development of an improved dynamic model of a Stirling engine and a performance analysis of a cogeneration plant. *Appl Therm Eng* 2014;73(1):608–21.
- [132] Ribberink H, Bourgeois D, Beausoleil-Morrison I. A plausible forecast of the energy and emissions performance of mature-technology Stirling engine residential cogeneration systems in Canada. *J Build Perform Simul* 2009;2(1):47–61.
- [133] Alanne K, Söderholm N, Sirén K, Beausoleil-Morrison I. Techno-economic assessment and optimization of Stirling engine micro-cogeneration systems in residential buildings. *Energy Convers Manage* 2010;51(12):2635–46.
- [134] Alanne K, Paatero J, Beausoleil-Morrison I. Performance assessment of a Stirling engine plant for local micro-cogeneration. *Int J Energy Res* 2012;36(2):218–30.
- [135] González-Pino I, Campos-Celador A, Pérez-Iribarren E, Terés-Zubiaga J, Sala JM. Parametric study of the operational and economic feasibility of Stirling micro-cogeneration devices in Spain. *Appl Therm Eng* 2014;71(2):821–9.
- [136] González-Pino I, Pérez-Iribarren E, Campos-Celador A, Las-Heras-Casas J, Sala JM. Influence of the regulation framework on the feasibility of a Stirling engine-based residential micro-CHP installation. *Energy* 2015;84:575–88.
- [137] Skorek-Osikowska A, Remiorz L, Bartela Ł, Kotowicz J. Potential for the use of micro-cogeneration prosumer systems based on the Stirling engine with an example in the Polish market. *Energy* 2017;133:46–61.
- [138] Meybodi MA, Behnia M. Australian coal mine methane emissions mitigation potential using a Stirling engine-based CHP system. *Energy Policy* 2013;62:10–8.
- [139] Ulloa C, Eguía P, Míguez JL, Porteiro J, Pousada-Carballo JM, Pousada-Carballo Cacabelos A, Antón Cacabelos. Feasibility of using a Stirling engine-based micro-CHP to provide heat and electricity to a recreational sailing boat in different European ports. *Appl Therm Eng* 2013;59(1–2):414–24.
- [140] Ulloa C, Porteiro J, Eguía P, Pousada-Carballo J. Application model for a Stirling engine micro-generation system in caravans in different European locations. *Energies* 2013;6(2):717–32.
- [141] Kim HJ, Lee YS, Ahn J. Combustion simulation of 1 kW class LNG Stirling engine CHP system considering heat recovery. *Int J Air-Condit Refrig* 2013;21(01):1350007.
- [142] Jin X, Lü T, Yu G, Liu J, Huang X. Design and combustion characteristic analysis of free piston Stirling engine external combustion system. *J Shanghai Jiaotong Univ (Sci)* 2018;23(1):50–5.
- [143] Solomon L, Qiu S. Computational analysis of external heat transfer for a tubular Stirling convertor. *Appl Therm Eng* 2018;137:134–41.
- [144] Yanaga K, Li R, Qiu S. Robust foil regenerator flow loss and heat transfer tests under oscillating flow condition. *Appl Therm Eng* 2020;178:115525.
- [145] Hooshang M, Moghadam RA, Nia SA, Masouleh MT. Optimization of Stirling engine design parameters using neural networks. *Renew Energy* 2015;74:855–66.
- [146] Zare SH, Tavakolpour-Saleh AR. Frequency-based design of a free piston Stirling engine using genetic algorithm. *Energy* 2016;109:466–80.
- [147] Qiu S, Augenblick J. Development and magnetic analysis of a Stirling convertor assembly linear alternator. In: 3rd international energy conversion engineering conference; 2005. p. 5653.
- [148] Dang TT, Rueilan M, Prevond L, Ahmed HB, Multon B. Sizing optimization of tubular linear induction generator and its possible application in high acceleration free-piston Stirling microcogeneration. *IEEE Trans Ind Appl* 2015;51(5):3716–33.
- [149] Qiu S, Solomon L. 7-free-piston Stirling engine generators. In: Energy conversion technologies and future trends; 2019. p. 105–25.
- [150] Gadre I, Maiorana J. Price model of the Stirling engine. KTH Industrial Engineering and Management; 2014.
- [151] Ibrahim MB, Tew Jr RC. Stirling convertor regenerators. Boca Raton: CRC Press; 2012.