

See discussions, stats, and author profiles for this publication at: <https://www.researchgate.net/publication/283986398>

Software Defined Optical Networks (SDONs): A Comprehensive Survey

Article in IEEE Communications Surveys & Tutorials · November 2015

DOI: 10.1109/COMST.2016.2586999 · Source: arXiv

CITATIONS

162

READS

1,467

4 authors, including:



Anu Mercian

Hewlett Packard Enterprise

13 PUBLICATIONS 278 CITATIONS

SEE PROFILE



Michael McGarry

University of Texas at El Paso

52 PUBLICATIONS 1,272 CITATIONS

SEE PROFILE

Some of the authors of this publication are also working on these related projects:



Network Intent Composition [View project](#)



Network Fault Detection [View project](#)

Software Defined Optical Networks (SDONs): A Comprehensive Survey

Akhilesh Thyagaturu, Anu Mercian, Michael P. McGarry, Martin Reisslein, and Wolfgang Kellerer

Abstract—The emerging Software Defined Networking (SDN) paradigm separates the data plane from the control plane and centralizes network control in an SDN controller. Applications interact with controllers to implement network services, such as network transport with Quality of Service (QoS). SDN facilitates the virtualization of network functions so that multiple virtual networks can operate over a given installed physical network infrastructure. Due to the specific characteristics of optical (photonic) communication components and the high optical transmission capacities, SDN based optical networking poses particular challenges, but holds also great potential. In this article, we comprehensively survey studies that examine the SDN paradigm in optical networks; in brief, we survey the area of Software Defined Optical Networks (SDONs). We mainly organize the SDON studies into studies focused on the infrastructure layer, the control layer, and the application layer. Moreover, we cover SDON studies focused on network virtualization, as well as SDON studies focused on the orchestration of multilayer and multidomain networking. Based on the survey, we identify open challenges for SDONs and outline future directions.

Index Terms—Control layer, infrastructure layer, optical network, orchestration, Software Defined Networking (SDN), virtual network.

I. INTRODUCTION

At least a decade ago [1] it was recognized that new network abstraction layers for network control functions needed to be developed to both simplify and automate network management. Software Defined Networking (SDN) [2]–[4] is the design principle that emerged to structure the development of those new abstraction layers. Fundamentally, SDN is defined by three architectural principles [5]: (i) the separation of control plane functions and data plane functions, (ii) the logical centralization of control, and (iii) programmability of network functions [6]. The first two architectural principles are related in that they combine to allow for network control functions to have a wider perspective on the network. The idea is that networks can be made easier to manage (i.e., control and monitor) with a move away from significantly distributed control. A tradeoff is then considered that balances ease of management arising from control centralization and scalability issues that naturally arise from that centralization.

Please direct correspondence to M. Reisslein

A. Thyagaturu, A. Mercian, and M. Reisslein are with the School of Electrical, Computer, and Energy Eng., Arizona State University, Tempe, AZ 85287-5706, USA, Phone: 480-965-8593, Fax: 480-965-8325, (e-mail: {athyagat, amercian, reisslein}@asu.edu).

M. McGarry is with the Dept. of Electr. and Comp. Eng., University of Texas at El Paso, El Paso, TX 79968, USA (email: mpmcgarry@utep.edu).

W. Kellerer is with the Lehrstuhl für Kommunikationsnetze, Technische Universität München, Munich, 80290, Germany, (email: wolkellerer@tum.de).

The SDN abstraction layering consists of three generally accepted layers [5] inspired by computing systems, from the bottom layer to the top layer: (i) the *infrastructure* layer, (ii) the *control* layer, and (iii) the *application* layer, as illustrated in Fig. 1. The interface between the application layer and the control layer is referred to as the NorthBound Interface (NBI), while the interface between the control layer and the infrastructure layer is referred to as the SouthBound Interface (SBI). There are a variety of standards emerging for these interfaces, e.g., the OpenFlow protocol [7] for the SBI.

The *application* layer is modeled after software applications that utilize computing resources to complete tasks. The *control* layer is modeled after a computer’s Operating System (OS) that manages computer resources (e.g., processors and memory), provides an abstraction layer to simplify interfacing with the computer’s devices, and provides a common set of services that all applications can leverage. Device drivers in a computer’s OS hide the details of interfacing with many different devices from the applications by offering a simple and unified interface for various device types. In the SDN model both the unified SBI (e.g., OpenFlow) as well as the control layer functionality provide the equivalent of a device driver for interfacing with devices in the *infrastructure* layer, e.g., packet switches.

Optical networks play an important role in our modern information technology due to their high transmission capacities. At the same time, the specific optical (photonic) transmission and switching characteristics, such as circuit, burst, and packet switching on wavelength channels, pose challenges for controlling optical networks. This article presents a comprehensive survey of Software Defined Optical Networks (SDONs). SDONs seek to leverage the flexibility of SDN control for supporting networking applications with an underlying optical network infrastructure. This survey comprehensively covers SDN related mechanisms that have been studied to date for optical networks.

A. Related Work

The general principles of SDN have been extensively covered in several surveys, see for instance, [2], [6], [7], [10]–[26]. SDN security has been surveyed in [27], [28], while management of SDN networks has been surveyed in [25] and SDN-based satellite networking is considered in [29].

To date, there have been relatively few overview and survey articles on SDONs. Zhang et al. [30] have presented a thorough survey on flexible optical networking based on Orthogonal Frequency Division Multiplexing (OFDM) in core

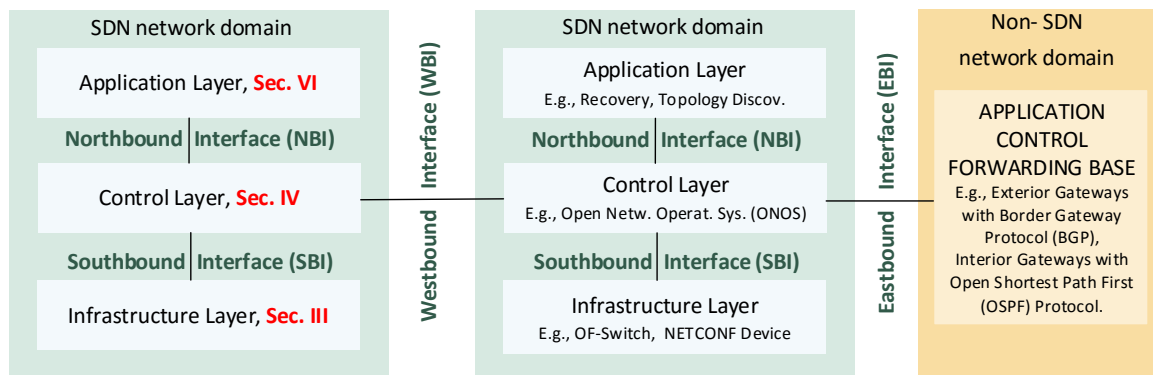

Fig. 1. Illustration of Software Defined Networking (SDN) abstraction layers: The infrastructure layer implements the data plane, e.g., with OpenFlow (OF) switches [7] or network elements (devices) controlled with the NETCONF protocol [8]. A controller at the control layer, e.g., the ONOS controller [9], controls the infrastructure layer based on the application layer requirements. The interface between the application and control layers is commonly referred to as the NorthBound Interface (NBI), while the interface between the control and infrastructure layers is commonly referred to as the SouthBound Interface (SBI). The WestBound Interface (WBI) interconnects multiple SDN domains, while the EastBound Interface (EBI) interconnects with non-SDN domains.

(backbone) networks. The survey briefly notes how OFDM-based elastic networking can facilitate network virtualization and surveys a few studies on OFDM-based network virtualization in core networks.

Bhaumik et al. [31] have presented an overview of SDN and network virtualization concepts and outlined principles for extending SDN and network virtualization concepts to the field of optical networking. Their focus has been mainly on industry efforts, reviewing white papers on SDN strategies from leading networking companies, such as Cisco, Juniper, Hewlett-Packard, Alcatel-Lucent, and Huawei. A few selected academic research projects on general SDN optical networks, namely projects reported in the journal articles [32], [33] and a few related conference papers, have also been reviewed by Bhaumik et al. [31]. In contrast to Bhaumik et al. [31], we provide a comprehensive up-to-date review of academic research on SDONs. Whereas Bhaumik et al. [31] presented a small sampling of SDON research organized by research projects, we present a comprehensive SDON survey that is organized according to the SDN infrastructure, control, and application layer architecture.

For the SDON sub-domain of access networks, Cvijetic [34] has given an overview of access network challenges that can be addressed with SDN. These challenges include lack of support for on-demand modifications of traffic transmission policies and rules and limitations to vendor-proprietary policies, rules, and software. Cvijetic [34] also offers a very brief overview of research progress for SDN-based optical access networks, mainly focusing on studies on the physical (photonics) infrastructure layer. Cvijetic [35] has further expanded the overview of SDON challenges by considering the incorporation of 5G wireless systems. Cvijetic [35] has noted that SDN access networks are highly promising for low-latency and high-bandwidth back-hauling from 5G cell base stations and briefly surveyed the requirements and areas of future research required for integrating 5G with SDON access networks. A related overview of general software defined access networks based on a variety of physical transmission media, including copper Digital Subscriber Line (DSL) [36] and Passive Optical Networks (PONs), has been presented by

Kerpez et al. [37].

Bitar [38] has surveyed use cases for SDN controlled broadband access, such as on-demand bandwidth boost, dynamic service re-provisioning, as well as value-add services and service protection. Bitar [38] has discussed the commercial perspective of the access networks that are enhanced with SDN to add cost-value to the network operation. Almeida Amazonas et al. [39] have surveyed the key issues of incorporating SDN in optical and wireless access networks. They briefly outlined the obstacles posed by the different specific physical characteristics of optical and wireless access networks.

Although our focus is on optical networks, for completeness we note that for the field of wireless and mobile networks, SDN based networking mechanisms have been surveyed in [40]–[46] while network virtualization has been surveyed in [47] for general wireless networks and in [48], [49] for wireless sensor networks. SDN and virtualization strategies for LTE wireless cellular networks have been surveyed in [50]. SDN-based 5G wireless network developments for mobile networks have been outlined in [51]–[54].

B. Survey Organization

We have mainly organize our survey according to the three-layer SDN architecture illustrated in Fig. 1. In particular, we have organized the survey in a bottom-up manner, surveying first SDON studies focused on the infrastructure layer in Section III. Subsequently, we survey SDON studies focused on the control layer in Section IV. The virtualization of optical networks is commonly closely related to the SDN control layer. Therefore, we survey SDON studies focused on virtualization in Section V, right after the SDON control layer section. Resuming the journey up the layers in Fig. 1, we survey SDON studies focused on the application layer in Section VI. We survey mechanisms for the overarching orchestration of the application layer and lower layers, possibly across multiple network domains (see Fig. 2), in Section VII. Finally, we outline open challenges and future research directions in Section VIII and conclude the survey in Section IX.

II. BACKGROUND

This section first provides background on Software Defined Networking (SDN), followed by background on virtualization and optical networking. SDN, as defined by the Internet Engineering Task Force (IETF) [55], is a networking paradigm enabling the programmability of networks. SDN abstracts and separates the data forwarding plane from the control plane, allowing faster technological development both in data and control planes. We provide background on the SDN architecture, including its architectural layers in Subsection II-A. The network programmability provides the flexibility to dynamically initialize, control, manipulate, and manage the end-to-end network behavior via open interfaces, which are reviewed in Subsection II-B. Subsequently, we provide background on network virtualization in Subsection II-C and on optical networking in Subsection II-D.

A. Software Defined Networking (SDN) Architectural Layers

SDN offers a simplified view of the underlying network infrastructure for the network control and monitoring applications through the abstraction of each independent network layer. Figure 1 illustrates the three-layer SDN architecture model consisting of application, control, and infrastructure layers as defined by the Open Networking Foundation (ONF) [5]. The ONF is the organization that is responsible for the publication of specifications for the OpenFlow protocol. The OpenFlow protocol [7], [56], [57] has been the first protocol for the SouthBound Interface (SBI, also referred to as Data-Controller Plane Interface (D-CPI)) between the control and infrastructure layers. Each layer operates independently, allowing multiple solutions to coexist within each layer, e.g., the infrastructure layer can be built from any programmable devices, which are commonly referred to as network elements [58] or network devices [55] (or sometimes as forwarding elements [59]). We will use the terminology network element throughout this survey. The SouthBound Interface (SBI) and the NorthBound Interface (NBI, also referred to as Application-Controller Plane Interface (A-CPI)) are defined as the primary interfaces interconnecting the SDN layers through abstractions. An SDN network architecture can coexist with both concurrent SDN architectures and non-SDN legacy network architectures. Additional interfaces are defined namely the EastBound Interface (EBI) and the WestBound Interface (WBI) [16] to interconnect the SDN architecture with external network architectures (the EBI and WBI are also collectively referred to as Intermediate-Controller Plane Interfaces (I-CPIs)). Generally, EBIs establish communication links to legacy network architectures (i.e., non-SDN networks); whereas, links to concurrent (side-by-side) SDN architectures are facilitated by the WBIs.

1) *Infrastructure Layer*: The infrastructure layer includes an environment for (payload) data traffic forwarding (data plane) either in virtual or actual hardware. The data plane comprises a network of network elements, which expose their capabilities through the SBI to the control plane. In traditional networking, control mechanisms are embedded within an infrastructure, i.e., decision making capabilities are embedded

within the infrastructure to perform network actions, such as switching or routing. Additionally, these forwarding actions in the traditional network elements are autonomously established based on self-evaluated topology information that is often obtained through proprietary vendor-specific algorithms. Therefore, the configuration setups of traditional network elements are generally not reconfigurable without a service disruption, limiting the network flexibility. In contrast, SDN decouples the autonomous control functions, such as forwarding algorithms and neighbor discovery of the network nodes, and moves these control functions out of the infrastructure to a centrally controlled logical node, the controller. In doing so, the network elements act only as dumb switches which act upon the instructions of the controller. This decoupling reduces the network element complexity and improves reconfigurability.

In addition to decoupling the control and data planes, packet modification capabilities at the line-rates of network elements have been significantly improved with SDN. P4 [60] is a programmable protocol-independent packet processor, that can arbitrarily match the fields within any formatted packet and is capable of applying any arbitrary actions (as programmed) on the packet before forwarding. A similar forwarding mechanism, Protocol-oblivious Forwarding (PoF) has been proposed by Huawei Technologies [61].

2) *Control Layer*: The control layer is responsible for programming (configuring) the network elements (switches) via the SBIs. The SDN controller is a logical entity that identifies the south bound instructions to configure the network infrastructure based on application layer requirements. To efficiently manage the network, SDN controllers can request information from the SDN infrastructures, such as flow statistics, topology information, neighbor relations, and link status from the network elements (nodes). The software entity that implements the SDN controller is often referred to as *Network Operating System (NOS)*. Generally, a NOS can be implemented independently of SDN, i.e., without supporting SDN. On the other hand, in addition to supporting SDN operations, a NOS can provide advanced capabilities, such as virtualization, application scheduling, and database management. The Open Network Operating System (ONOS) [9] is an example of an SDN based NOS with a distributed control architecture designed to operate over Wide Area Networks (WANs). Furthermore, Cisco has recently developed the one Platform Kit (onePK) [62], which consists of a set of Application Program Interfaces (APIs) that allow the network applications to control Cisco network devices without a command line interface. The onePK libraries act as an SBI for Cisco ONE controllers and are based on C and Java compilers.

3) *Application Layer*: The application layer comprises network applications and services that utilize the control plane to realize network functions over the physical or virtual infrastructure. Examples of network applications include network topology discovery, provisioning, and fault restoration. The SDN controller presents an abstracted view of the network to the SDN applications to facilitate the realization of application functionalities. The applications can also include higher levels of network management, such as network data analytics, or specialized functions requiring processing in large data

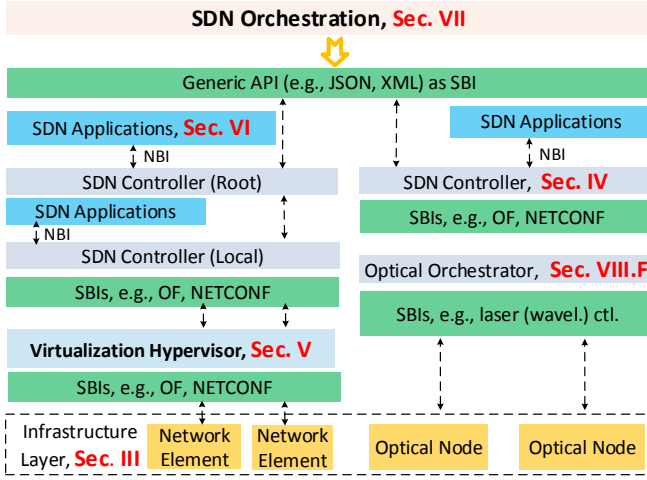

Fig. 2. Overview of SDN orchestrator and SDN controllers: The SDN orchestration coordinates and manages at a higher abstracted layer, above the SDN applications and SDN controllers. SDN controllers, which may be in a hierarchy (see left part), implement the orchestrator decisions. A virtualization hypervisor may intercept the SouthBound Interfaces (SBIs) to create multiple virtual networks from a given physical network infrastructure. (The optical orchestrator on the right can be ignored for now and will be addressed in Section VIII-F.)

centers. For instance, the Central Office Re-architected as a Data center (CORD) [63] is an SDN application based on ONOS [9], that implements the typical central office network functions, such as optical line termination, as well as BaseBand Unit (BBU) and Data Over Cable Interface (DOCSIS) [64] processing as virtualized software entities, i.e., as SDN applications.

4) *Orchestration Layer*: Although the orchestration layer is commonly not considered one of the main SDN architectural layers illustrated in Fig. 1, as SDN systems become more complex, orchestration becomes increasingly important. We introduce therefore the orchestration layer as an important SDN architectural layer in this background section. Typically, an SDN orchestrator is the entity that coordinates software modules within a single SDN controller, a hierarchical structure of multiple SDN controllers, or a set of multiple SDN controllers in a “flat” arrangement (i.e., without a hierarchy) as illustrated in Fig. 2. An SDN controller in contrast can be viewed as a logically centralized single control entity. This logically centralized single control entity appears as the directly controlling entity to the network elements. The SDN controller is responsible for signaling the control actions or rules that are typically predefined (e.g., through OpenFlow) to the network elements. In contrast, the SDN orchestrator makes control decisions that are generally not predefined. More specifically, the SDN orchestrator could make an automated decision with the help of SDN applications or seek a manual recommendation from user inputs; therefore, results are generally not predefined. These orchestrator decisions (actions/configurations) are then delegated via the SDN controllers and the SBIs to the network elements.

Intuitively speaking, SDN orchestration can be viewed as a distinct abstracted (higher) layer for coordination and management that is positioned above the SDN control and application layers. Therefore, we generalize the term SDN

orchestrator as an entity that realizes a wider, more general (more encompassing) network functionality as compared to the SDN controllers. For instance, a cloud SDN orchestrator can instantiate and tear down Virtual Machines (VMs) according to the cloud workload, i.e., make decisions that span across multiple network domains and layers. In contrast, SDN controllers realize more specific network functions, such as routing and path computation.

B. SDN Interfaces

1) *Northbound Interfaces (NBIs)*: A logical interface that interconnects the SDN controller and a software entity operating at the application layer is commonly referred to as a NorthBound Interface (NBI), or as Application-Controller Plane Interface (A-CPI).

a) *REST*: REpresentational State Transfer (REST) [65] is generally defined as a software architectural style that supports flexibility, interoperability, and scalability. In the context of the SDN NBI, REST is commonly defined as an API that meets the REST architectural style [66], i.e., is a so-called RESTful API:

- **Client-Sever**: Two software entities should follow the client-server model. In SDN, a controller can be a server and the application can be the client. This allows multiple heterogeneous SDN applications to coexist and operate over a common SDN controller.
- **Stateless**: The client is responsible for managing all the states and the server acts upon the client’s request. In SDN, the applications collect and maintain the states of the network, while the controller follows the instructions from the applications.
- **Caching**: The client has to support the temporary local storage of information such that interactions between the client and server are reduced so as to improve performance and scalability.
- **Uniform/Interface Contract**: An overarching technical interface must be followed across all services using the REST API. For example, the same data format, such as Java Script Object Notation (JSON) or eXtended Markup Language (XML), has to be followed for all interactions sharing the common interface.
- **Layered System**: In a multilayered architectural solution, the interface should only be concerned with the next immediate node and not beyond. Thus, allowing more layers to be inserted, modified, or removed without affecting the rest of the system.

2) *Southbound Interfaces (SBIs)*: A logical interface that interconnects the SDN controller and the network element operating on the infrastructure layer (data plane) is commonly referred to as a SouthBound Interface (SBI), or as the Data-Controller Plane Interface (D-CPI). Although a higher level connection, such as a UDP or TCP connection, is sufficient for enabling the communication between two entities of the SDN architecture, e.g., the controller and the network elements, specific SBI protocols have been proposed. These SBI protocols are typically not interoperable and thus are limited to work with SBI protocol-specific network elements

(e.g., an OpenFlow switch does not work with the NETCONF protocol).

a) OpenFlow Protocol: The interaction between an OpenFlow switching element (data plane) and an OpenFlow controller (control plane) is carried out through the OpenFlow protocol [7], [57]. This SBI (or D-CPI) is therefore also sometimes referred to as the OpenFlow control channel. SDN mainly operates through packet flows that are identified through matches on prescribed packet fields that are specified in the OpenFlow protocol specification. For matched packets, SDN switches then take prescribed actions, e.g., process the flow's packets in a particular way, such as dropping the packet, duplicating it on a different port or modifying the header information.

b) Path Computation Element Protocol (PCEP): The PCEP enables communication between the Path Computation Client (PCC) of the network elements and the Path Computation Element (PCE) residing within the controller. The PCE centrally computes the paths based on constraints received from the network elements. Computed paths are then forwarded to the individual network elements through the PCEP protocol [67], [68].

c) Network Configuration Protocol (NETCONF) Protocol: The NETCONF protocol [8] provides mechanisms to configure, modify, and delete configurations on a network device. Configuration of the data and protocol messages are encoded in the NETCONF protocol using an eXtensible Markup Language (XML). Remote procedure calls are used to realize the NETCONF protocol operations. Therefore, only devices that are enabled with required remote procedure calls allow the NETCONF protocol to remotely modify device configurations.

d) Border Gateway Protocol Link State Distribution (BGP-LS) Protocol: The central controller needs a topology information database, also known as Traffic Engineering Database (TED), for optimized end-to-end path computation. The controller has to request the information for building the TED, such as topology and bandwidth utilization, via the SBIs from the network elements. This information can be gathered by a BGP extension, which is referred to as BGP-LS.

C. Network Virtualization

Analogously to the virtualization of computing resources [69], [70], network virtualization abstracts the underlying physical network infrastructure so that one or multiple virtual networks can operate on a given physical network [71]–[79]. Virtual networks can span over a single or multiple physical infrastructures (e.g., geographically separated WAN segments). Network Virtualization (NV) can flexibly create independent virtual networks (slices) for distinct users over a given physical infrastructure. Each network slice can be created with prescribed resource allocations. When no longer required, a slice can be deleted, freeing up the reserved physical resources.

Network hypervisors [80], [81] are the network elements that abstract the physical network infrastructure (including network elements, communication links, and control functions)

into logically isolated virtual network slices. In particular, in the case of an underlying physical SDN network, an SDN hypervisor can create multiple isolated virtual SDN networks [82], [83]. Through hypervisors, NV supports the implementation of a wide range of network services belonging to the link and network protocol layers (L2 and L3), such as switching and routing. Additionally, virtualized infrastructures can also support higher layer services, such as load-balancing of servers and firewalls. The implementation of such higher layer services in a virtualized environment is commonly referred to as Network Function Virtualization (NFV) [84]–[86]. NFV can be viewed as a special case of NV in which network functions, such as address translation and intrusion detection functions, are implemented in a virtualized environment. That is, the virtualized functions are implemented in the form of software entities (modules) running on a data center (DC) or the cloud [87]. In contrast, the term NV emphasizes the virtualization of the network resources, such as communication links and network nodes.

D. Optical Networking Background

1) Optical Switching Paradigms: Optical networks are networks that either maintain signals in the optical domain or at least utilize transmission channels that carry signals in the optical domain. In optical networks that maintain signals in the optical domain, switching can be performed at the *circuit, packet, or burst* granularities.

a) Circuit Switching: Optical *circuit* switching can be performed in space, waveband, wavelength, or time. The optical spectrum is divided into wavelengths either on a fixed wavelength grid or on a flexible wavelength grid. Spectrally adjacent wavelengths can be coalesced into wavebands. The fixed wavelength grid standard (ITU-T G.694.1) specifies specific center frequencies that are either 12.5 GHz, 25 GHz, 50 GHz, or 100 GHz apart. The flexible DWDM grid (flexi-grid) standard (ITU-T G.694.1) [30], [88]–[90] allows the center frequency to be any multiple of 6.25 GHz away from 193.1 THz and the spectral width to be any multiple of 12.5 GHz. Elastic Optical Networks (EONs) [91]–[93] that take advantage of the flexible grid can make more efficient use of the optical spectrum but can cause spectral fragmentation, as lightpaths are set up and torn down, the spectral fragmentation counteracts the more efficient spectrum utilization [94].

b) Packet Switching: Optical *packet* switching performs packet-by-packet switching using header fields in the optical domain as much as possible. An all-optical packet switch requires [95]:

- Optical synchronization, demultiplexing, and multiplexing
- Optical packet forwarding table computation
- Optical packet forwarding table lookup
- Optical switch fabric
- Optical buffering

Optical packet switches typically relegate some of these design elements to the electrical domain. Most commonly the packet forwarding table computation and lookup is performed electrically. When there is contention for a destination port,

a packet needs to be buffered optically, this buffering can be accomplished with rather impractical fiber delay lines. Fiber delay lines are fiber optic cables whose lengths are configured to provide a certain time delay of the optical signal; e.g., 100 meters of fiber provides 500 ns of delay. An alternative to buffering is to either drop the packet or to use deflection routing, whereby a packet is routed to a different output that may or may not lead to the desired destination.

c) Burst Switching: Optical *burst* switching alleviates the requirements of optical packet forwarding table computation, forwarding table lookup, as well as buffering while accommodating bursty traffic that would lead to poor utilization of optical circuits. In essence, it permits the rapid establishment of short-lived optical circuits to support the transfer of one or more packets coalesced into a burst. A control packet is sent through the network that establishes the lightpath for the burst and then the burst is transmitted on the short-lived circuit with no packet lookup or buffering required along the path [95]. Since the circuit is only established for the length of the burst, network resources are not wasted during idle periods. To avoid any buffering of the burst in the optical network, the burst transmission can begin once the lightpath establishment has been confirmed (tell-and-wait) or a short time period after the control packet is sent (just-enough-time). *Note:* sending the burst immediately after the control packet (tell-and-go) would require some buffering of the optical burst at the switching nodes.

2) *Optical Network Structure:* Optical networks are typically structured into three main tiers, namely access networks, metropolitan (metro) area networks, and backbone (core) networks [96].

a) Access Networks: In the area of optical access networks [97], so-called Passive Optical Networks (PONs), in particular, Ethernet PONs (EPONs) and Gigabit PONs (GPONs) [98], [99], have been widely studied. A PON has typically an inverse tree structure with a central Optical Line Terminal (OLT) connecting multiple distributed Optical Network Units (ONUs; also referred to as Optical Network Terminals, ONTs) to metro networks. In the downstream (OLT to ONUs) direction, the OLT broadcasts transmissions. However, in the upstream (ONUs to OLT) direction, the transmissions of the distributed ONUs need to be coordinated to avoid collisions on the shared upstream wavelength channel. Typically, a cyclic polling based Medium Access Control (MAC) protocol, e.g., based on the MultiPoint Control Protocol (MPCP, IEEE 802.3ah), is employed. The ONUs report their bandwidth demands to the OLT and the OLT then assigns upstream transmission windows according to a Dynamic Bandwidth Allocation (DBA) algorithm [100]–[102]. Conventional PONs cover distances up to 20 km, while so-called Long-Reach (LR) PONs cover distances up to around 100 km [103].

Recently, hybrid access networks that combine multiple transmission media, such as Fiber-Wireless (FiWi) networks [104]–[108] and PON-DSL networks [109], have been explored to take advantage of the respective strengths of the different transmission media.

b) Networks Connected to Access Networks: Optical access networks provide Internet connectivity for a wide range of peripheral networks. Residential (home) wired or wireless local area networks [110] typically interconnect individual end devices (hosts) in a home or small business and may connect directly with an optical access network. Cellular wireless networks provide Internet access to a wide range of mobile devices [111]–[113]. Specialized cellular backhaul networks [114]–[120] relay the traffic to/from base stations of wireless cellular networks to either wireless access networks [121]–[126] or optical access networks. Moreover, optical access networks are often employed to connect Data Center (DC) networks to the Internet. DC networks interconnect highly specialized server units that process and store large data amounts with specialized networking technologies [127]–[129]. Data centers are typically employed to provide the so-called “cloud” services for commercial and social media applications.

c) Metropolitan Area Networks: Optical Metropolitan (metro) Area Networks (MANs) interconnect the optical access networks in a metropolitan area with each other and with wide-area (backbone, core) networks. MANs have typically a ring or star topology [130]–[133] and commonly employ optical networking technologies.

d) Backbone Networks: Optical backbone (wide area) networks interconnect the individual MANs on a national or international scale. Backbone networks have typically a mesh structure and employ very high speed optical transmission links.

III. SDN CONTROLLED PHOTONIC COMMUNICATION INFRASTRUCTURE LAYER

This section surveys mechanisms for controlling physical layer aspects of the optical (photonic) communication infrastructure through SDN. Enabling the SDN control down to the photonic level operation of optical communications allows for flexible adaptation of the photonic components supporting optical networking functionalities [32], [194]–[196]. As illustrated in Fig. 3, this section first surveys transmitters and receivers (collectively referred to as transceivers or transponders) that permit SDN control of the optical signal transmission characteristics, such as modulation format. We also survey SDN controlled space division multiplexing (SDM), which provides an emerging avenue for highly efficient optical transmissions. Then, we survey SDN controlled optical switching, covering first switching elements and then overall switching paradigms, such as converged packet and circuit switching. Finally, we survey cognitive photonic communication infrastructures that monitor the optical signal quality. The optical signal quality information can be used to dynamically control the transceivers as well as the filters in switching elements.

A. Transceivers

Software defined optical transceivers are optical transmitters and receivers that can be flexibly configured by SDN to transmit or receive a wide range of optical signals [197]. Generally, software defined optical transceivers vary the modulation

SDN Controlled Photonic Communication Infrastructure Layer, Sec. III

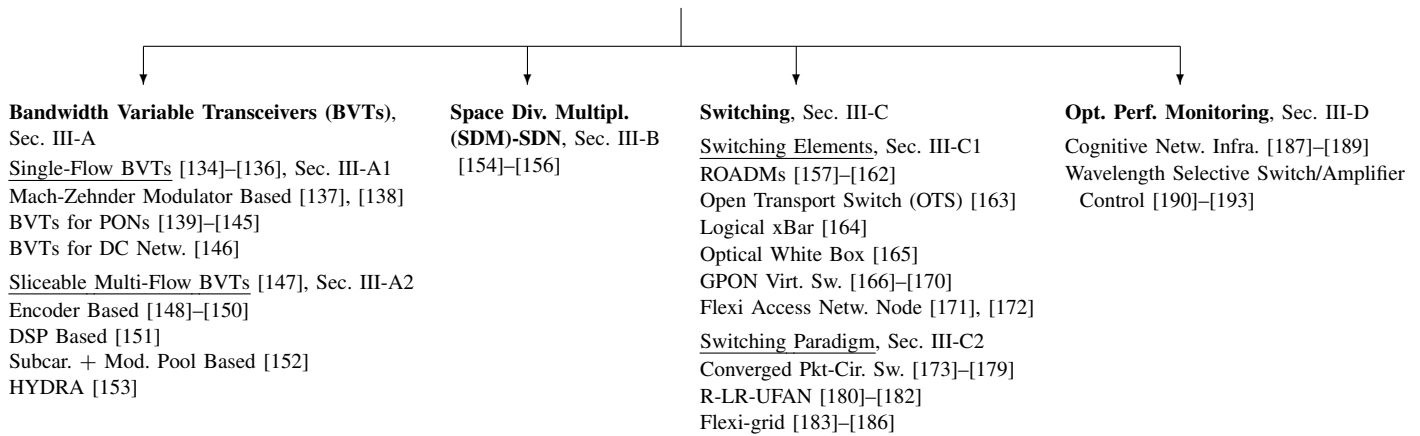

Fig. 3. Classification of physical infrastructure layer SDN studies.

format [198] of the transmitted optical signal by adjusting the transmitter and receiver operation through Digital Signal Processing (DSP) techniques [199]–[201]. These transceivers have evolved in recent years from Bandwidth Variable Transceivers (BVTs) generating a single signal flow to sliceable multi-flow BVTs. Single-flow BVTs permit SDN control to adjust the transmission bandwidth of the single generated signal flow. In contrast, sliceable multi-flow BVTs allow for the independent SDN control of multiple communication traffic flows generated by a single BVT.

1) *Single-Flow Bandwidth Variable Transceivers (BVTs)*: Software defined optical transceivers have initially been examined in the context of adjusting a single optical signal flow for flexible WDM networking [134]–[136]. The goal has been to make the photonic transmission characteristics of a given transmitter fully programmable. We proceed to review a representative single-flow BVT design for general optical mesh networks in detail and then summarize related single-flow BVTs for PONs and data center networks.

a) *Mach-Zehnder Modulator Based Flexible Transmitter*: Choi and Liu et al. [137], [138] have demonstrated a flexible transmitter based on Mach-Zehnder Modulators (MZMs) [202] and a corresponding flexible receiver for SDN control in a general mesh network. The flexible transceiver employs a single dual-drive MZM that is fed by two binary electric signals as well as a parallel arrangement of two MZMs which are fed by two additional electrical signals. Through adjusting the direct current bias voltages and amplitudes of drive signals the combination of MZMs can vary the amplitude and phase of the generated optical signal [203]. Thus, modulation formats ranging from Binary Phase Shift Keying (BPSK) to Quadrature Phase Shift Keying (QPSK) as well as 8 and 16 quadrature amplitude modulation [198] can be generated. The amplitudes and bias voltages of the drive signals can be signaled through an SDN OpenFlow control plane to achieve the different modulation formats. The corresponding flexible receiver consists of a polarization filter that feeds four parallel photodetectors, each followed by an Analog-to-Digital Converter (ADC). The outputs of the four parallel ADCs are then processed with DSP techniques to automatically (without SDN control) detect the

modulation format. Experiments in [137], [138] have evaluated the bit error rates and transmission capacities of the different modulation formats and have demonstrated the SDN control.

b) *Single-Flow BVTs for PONs*: Flexible optical networking with real-time bandwidth adjustments is also highly desirable for PON access and metro networks, albeit the BVT technologies for access and metro networks should have low cost and complexity [139]. Iiyama et al. [140] have developed a DSP based approach that employs SDN to coordinate the downstream PON transmission of On-Off Keying (OOK) modulation [141] and Quadrature Amplitude Modulation (QAM) [142] signals. The OOK-QAM-SDN scheme involves a novel multiplexing method, wherein all the data are simultaneously sent from the OLT to the ONUs and the ONUs filter the data they need. The experimental setup in [140] also demonstrated digital software ONUs that concurrently transmit data by exploiting the coexistence of OOK and QAM. The OOK-QAM-SDN evaluations demonstrated the control of the receiving sensitivity which is very useful for a wide range of transmission environments.

In a related study, Vacondio et al. [143] have examined Software-Defined Coherent Transponders (SDCT) for TDMA PON access networks. The proposed SDCT digitally processes the burst transmissions to achieve improved burst mode transmissions according to the distance of a user from the OLT. The performance results indicate that the proposed flexible approach more than doubles the average transmission capacity per user compared to a static approach.

Bolea et al. [144], [145] have recently developed low-complexity DSP reconfigurable ONU and OLT designs for SDN-controlled PON communication. The proposed communication is based on carrierless amplitude and phase modulation [204] enhanced with optical Orthogonal frequency Division Multiplexing (OFDM) [144]. The different OFDM channels are manipulated through DSP filtering. As illustrated in Fig. 4, the ONU consists of a DSP controller that controls the filter coefficients of the shaping filter. The filter output is then passed through a Digital-to-Analog Converter (DAC) and intensity modulator for electric-optical conversion. At the OLT, a photo diode converts the optical signal to an

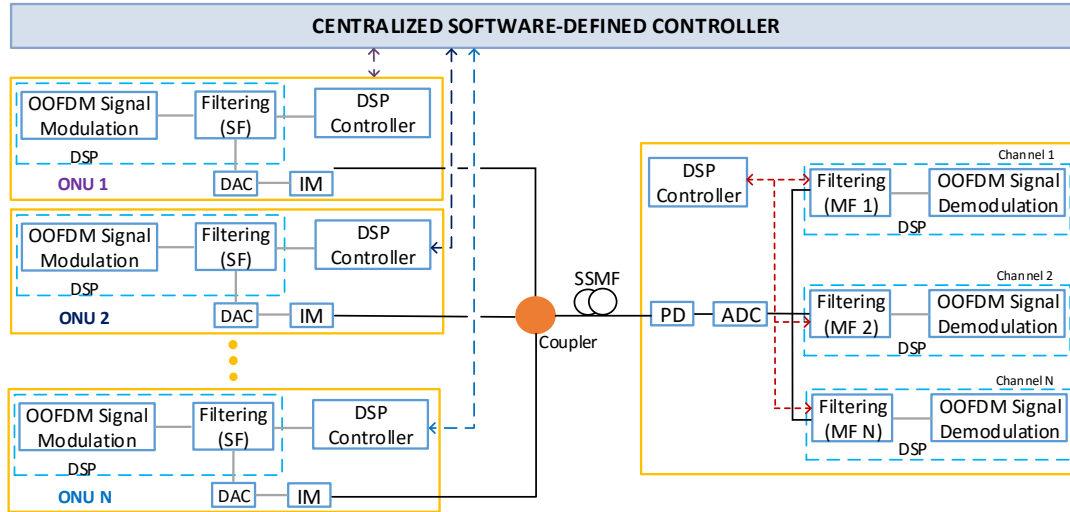

Fig. 4. Illustration of DSP reconfigurable ONU and OLT designs [145]; Each ONU passes the electrical Optical OFDM signal [144] through a Shaping Filter (SF) that is SDN-configured by the DSP controller, followed by a Digital-to-Analog Converter (DAC) and Intensity Modulator (IM) to generate the optical signal. The centralized SDN controller configures the corresponding OLT Matching Filter (MF) and ensures that all ONU filters are orthogonal.

electrical signal, which then passes through an Analog-to-Digital Converter (ADC). The SDN controlled OLT DSP controller sets the filter coefficients in the matching filter to correspond to the filtering in the sending ONU. The OLT DSP controller is also responsible for ensuring the orthogonality of all the ONU filters in the PON. The performance evaluations in [145] indicate that the proposed DSP reconfigurable ONU and OLT system achieves ONU signal bitrates around 3.7 Gb/s for eight ONUs transmitting upstream over a 25 km PON. The performance evaluations also illustrate that long DSP filter lengths, which increase the filter complexity, improve performance.

c) Single-Flow BVTs for Data Center Networks:

Malacarne [146] have developed a low-complexity and low-cost bandwidth adaptable transmitter for data center networking. The transmitter can multiplex Amplitude Shift Keying (ASK), specifically On-Off Keying (OOK), and Phase Shift Keying (PSK) on the same optical carrier signal without any special synchronization or temporal alignment mechanism. In particular, the transmitter design [146] uses the OOK electronic signal to drive a Mach-Zehnder Modulator (MZM) that is fed by the optical pulse modulated signal. SDN control can activate (or de-activate) the OOK signal stream, i.e., adapt from transmitting only the PSK signal to transmitting both the PSK and OOK signal and thus providing a higher transmission bit rate.

2) Sliceable Multi-Flow Bandwidth Variable Transceivers:

Whereas the single-flow transceivers surveyed in Section III-A1 generate a single optical signal flow, parallelization efforts have resulted in multi-flow transceivers (transponders) [147]. Multi-flow transceivers can generate multiple parallel optical signal flows and thus form the infrastructure basis for network virtualization.

a) Encoder Based Programmable Transponder:

Sambo et al. [148], [149] have developed an SDN-programmable bandwidth-variable multi-flow transmitter and corresponding SDN-programmable multi-flow bandwidth variable receiver, referred to jointly as programmable

bandwidth-variable transponder. The transmitter mainly consists of a programmable encoder and multiple parallel Polarization-Multiplexing Quadrature Phase Shift Keying (PM-QPSK [198]) laser transmitters, whose signals are multiplexed by a coupler. The encoder is SDN-controlled to implement Low-Density Parity-Check (LDPC) coding [205] with different code rates. At the receiver, the SDN control sets the local oscillators and LDPC decoder. The developed transponder allows the setting of the number of subcarriers, the subcarrier bitrate, and the LDPC coding rate through SDN. Related frequency conversion and defragmentation issues have been examined in [206]. In [150], a low-cost version of the SDN programmable transponder with a multiwavelength source has been developed. The multiwavelength source is based on a micro-ring resonator [207] that generates multiple signal carriers with only a single laser.

b) *DSP Based Sliceable BVT*: Morelo et al. [151] have developed an SDN controlled sliceable BVT based on adaptive Digital Signal Processing (DSP) of multiple parallel signal subcarriers. Each subcarrier is fed by a DSP module that configures the modulation format, including the bit rate setting, and the power level of the carrier by adapting a gain coefficient. The output of the DSP module is then passed through digital to analog conversion that drives laser sources. The parallel flows can be combined with a wavelength selective switch; the combined flow can be sliced into multiple distinct sub-flows for distinct destinations. The functionality of the developed DSP based BVT has been verified for a metropolitan area network with links reaching up to 150 km.

c) *Subcarrier and Modulator Pool Based Virtualizable BVT*: Ou et al. [152] have developed a Virtualizable BVT (V-BVT) based on a combination of an optical subcarriers pool with an independent optical modulators pool, as illustrated in Fig. 5. The emphasis of the design is on implementing Virtual Optical Networks (VONs) at the transceiver level. The optical subcarriers pool contains multiple optical carriers, whereby channel spacing and central frequency (wavelength channel) can be selected. The optical modulators pool con-

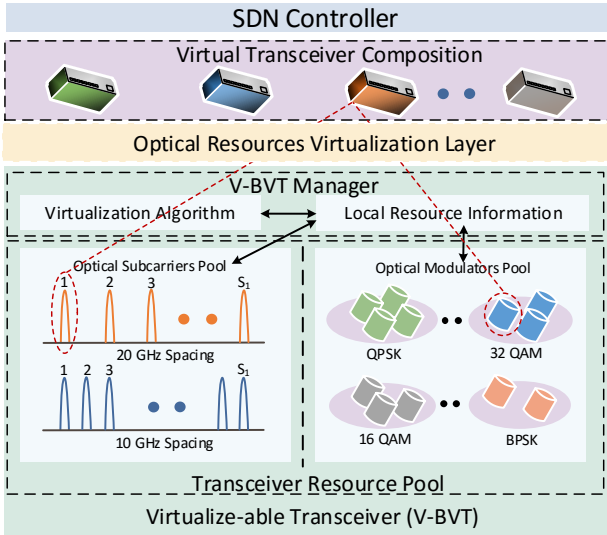

Fig. 5. Illustration of Subcarrier and Modulator Pool Based Virtualizable Bandwidth Variable Transceiver (V-BVT) [152]: Through SDN control, the V-BVT Manager composes virtual transceivers by combining subcarriers from the optical subcarriers pool with modulators from the optical modulators pool.

tains optical modulators that can generate a wide variety of modulation formats. The SDN control interacts with a V-BVT Manager that implements a virtualization algorithm. The virtualization algorithm generates a transceiver slice by combining a particular set of subcarriers (with specific number of subcarriers, channel spacing, and central frequencies) from the optical subcarriers pool with a particular modulation (with specific number of modulators and modulation formats) from the optical modulators pool. The evaluations in [152] have evaluated the proposed V-BVT in a network testbed with path lengths up to 200 km with 20 GHz channel spacing and a variety of modulation formats, including BPSK as well as 16QAM and 32QAM.

d) S-BVT Based Hybrid Long-Reach Fiber Access Network (HYDRA): HYDRA [153] is a novel hybrid long-reach fiber access network architecture based on sliceable BVTs. HYDRA supports low-cost end-user ONUs through an Active Remote Node (ARN) that directly connects via a distribution fiber segment, a passive remote node, and a trunk fiber segment to the core (backbone) network, bypassing the conventional metro network. The ARN is based on an SDN controlled S-BVT to optimize the modulation format. With the modulation format optimization, the ARN can optimize the transmission capacity for the given distance (via the distribution and trunk fiber segments) to the core network. The evaluations in [153] demonstrate good bit error rate performance of representative HYDRA scenarios with a 200 km trunk fiber segment and distribution fiber lengths up to 100 km. In particular, distribution fiber lengths up to around 70 km can be supported without Forward Error Correction (FEC), whereas distribution fiber lengths above 70 km would require standard FEC. The consolidation of the access and metro network infrastructure [208] achieved through the optimized S-BVT transmissions can significantly reduce the network cost and power consumption.

B. Space Division Multiplexing (SDM)-SDN

Amaya et al. [154], [155] have demonstrated SDN control of Space Division Multiplexing (SDM) [209] in optical networks. More specifically, Amaya et al. employ SDN to control the physical layer so as to achieve a bandwidth-flexible and programmable SDM optical network. The SDN control can perform network slicing, resulting in sliceable superchannels. A superchannel consists of multiple spatial carriers to support dynamic bandwidth and QoS provisioning.

Galve et al. [156] have built on the flexible SDN controlled SDM communication principles to develop a reconfigurable Radio Access Network (RAN). The RAN connects the Base-Band processing Units (BBUs) in a shared central office with the corresponding distributed Remote Radio Heads (RRHs) located at Base Stations (BSs). A multicore fiber operated with SDM [209] connects the RRHs to the BBUs in the central office. Galve et al. introduce a radio over fiber operation mode where SDN controlled switching maps the subcarriers dynamically to spatial output ports. A complementary digitized radio over fiber operating mode maintains a BBU pool. Virtual BBUs are dynamically allocated to the cores of the SDM operated multicore fiber.

C. SDN-Controlled Switching

1) Switching Elements:

a) ROADM: The Reconfigurable Optical Add-Drop Multiplexer (ROADM) is an important photonic switching device for optical networks. Through wavelength selective optical switches, a ROADM can drop (or add) one or multiple wavelength channels carrying optical data signals from (to) a fiber without requiring the conversion of the optical signal to electric signals [210]. The ROADM thus provides an elementary switching functionality in the optical wavelength domain. Initial ROADM based node architectures for cost-effectively supporting flexible SDN networks have been presented in [157]. Conventional ROADM networks have typically statically configured wavelength channels that transport traffic along a pre-configured route. Changes of wavelength channels or routes in the statically configured networks incur presently high operational costs due to required physical interventions and are therefore typically avoided. New ROADM node designs allow changes of wavelength channels and routes through a management control plane. Due to these two flexibility dimensions (wavelength and route), these new ROADM nodes are referred to as “colorless” and “directionless”. First designs for such colorless and directionless ROADM nodes have been outlined in [157] and further elaborated in [158], [159]. In addition to the colorless and directionless properties, the contentionless property has emerged for ROADMs [136]. Contentionless ROADM operation means that any port can be routed on any wavelength (color) in any direction without causing resource contention. Designs for such Colorless-Directionless-Contentionless (CDC) ROADMs have been proposed in [160], [161]. In general, the ROADM designs consist of an express bank that interconnects the input and output ports coming from/leading to other ROADMs, and an add-drop bank that connects the express bank with the local receivers for

dropped wavelength channels or transmitters for added wavelength channels. The recent designs have focused on the add-drop bank and explored different arrangements of wavelength selective switches and multicast switches to provide add-drop bank functionality with the CDC property [160], [161].

Garrich et al. [162] have recently designed and demonstrated a CDC ROADM with an add-drop bank based on an Optical Cross-Connect (OXC) backplane [211]. The OXC backplane allows for highly flexible add/drop configurations implemented through SDN control. The backplane based ROADM has been analytically compared with prior designs based on wavelength selective and multicast switches and has been shown to achieve higher flexibility and lower losses. An experimental evaluation has tested the backplane based ROADM for a metropolitan area mesh network extending over 100 km with an aggregate traffic load of close to 9 Tb/s.

b) Open Transport Switch (OTS): The Open Transport Switch (OTS) [163] is an OpenFlow-enabled optical virtual switch design. The OTS design abstracts the details of the underlying physical switching layer (which could be packet switching or circuit switching) to a virtual switch element. The OTS design introduces three agent modules (discovery, control, and data plane) to interface with the physical switching hardware. These agent modules are controlled from an SDN controller through extended OpenFlow messages. Performance measurements for an example testbed network setup indicate that the circuit path computation latencies on the order of 2–3 s that can be reduced through faster processing in the controller.

c) Logical xBar: The logical xBar [164] has been defined to represent a programmable switch. An elementary (small) xBar could consist of a single OpenFlow switch. Multiple small xBars can be recursively merged to form a single large xBar with a single forwarding table. The xBar concept envisions that xBars are the building blocks for forming large networks. Moreover, labels based on SDN and MPLS are envisioned for managing the xBar data plane forwarding. The xBar concepts have been further advanced in the Orion study [212] to achieve low computational complexity of the SDN control plane.

d) Optical White Box: Nejabati et al. [165] have proposed an optical white box switch design as a building block for a completely softwarized optical network. The optical white box design combines a programmable backplane with programmable switching node elements. More specifically, the backplane consists of two slivers, namely an optical backplane sliver and an electronic backplane sliver. These slivers are set up to allow for flexible arbitrary connections between the switch node elements. The switch node elements include programmable interfaces that build on SDN-controlled BVTs, see Section III-A, protocol agnostic switching, and DSP elements. The protocol agnostic switching element is envisioned to support both wavelength channel and time slot switching in the optical backplane as well as programmable switching with a high-speed packet processor in the electronic backplane. The DSP elements support both the network processing and the signal processing for executing a wide range of network functions. A prototype of the optical white box has been built with only a optical backplane sliver consisting of a 192×192

optical space switch. Experiments have indicated that the creation of a virtual switching node with the OpenDayLight SDN controller takes roughly 400 ms.

e) GPON Virtual Switch: Lee et al. [166] have developed a GPON virtual switch design that makes the GPON fully programmable similar to a conventional OpenFlow switch. Preliminary steps towards the GPON virtual switch design have been taken by Gu et al. [167] who developed components for SDN control of a PON in a data center and Amokrane et al. [168], [169] who developed a module for mapping OpenFlow flow control requests into PON configuration commands. Lee et al. [166] have expanded on this groundwork to abstract the entire GPON into a virtual OpenFlow switch. More specifically, Lee et al. have comprehensively designed a hardware architecture and a software architecture to allow SDN control to interface with the virtual GPON as if it were a standard OpenFlow switch. The experimental performance evaluation of the designed GPON virtual switch measured response times for flow entry modifications from an ONU port (where a subscriber connects to the virtual GPON switch) to an SDN external port around 0.6 ms, which compares to 0.2 ms for a corresponding flow entry modification in a conventional OFsoftswitch and 1.7 ms in a EdgeCore AS4600 switch. In a related study on SDN controlled switching in a PON, Yeh et al. [170] have designed an ONU with an optical switch that selects OFDM subchannels in a TWDM-PON. The switch in the ONU allows for flexible dynamic adaption of the downstream bandwidth through SDN.

f) Flexi Access Network Node: A flexi-node for an access network that flexibly aggregates traffic flows from a wide range of networks, such as local area networks and base stations of wireless networks has been proposed in [171]. The flexi-node design is motivated by the shortcomings of the currently deployed core/metro network architectures that attempt to consolidate the access and metro networks. This consolidation forces all traffic in the access network to traverse the metro network, even if the traffic is destined to destination nodes in the coverage area of an access network. In contrast, the proposed flexi-node encompasses electrical and optical forwarding capabilities that can be controlled through SDN. The flexi-node can thus serve as an effective aggregation node in access-metro networks. Traffic that is destined to other nodes in the coverage area of an access network can be sent directly to the access network.

Kondepu et al. have similarly presented an SDN based PON aggregation node [172]. In their architecture, multiple ONUs communicate with the SDN controller within the aggregation node to request the scheduling of upstream transmission resources. ONUs are then serviced by multiple Optical Service Units (OSUs) which exist within the aggregation node alongside with the SDN controller. OSUs are then configured by the controller based on Time and Wavelength Division Multiplexed (TWDM) PON. The OSUs step between normal and sleep-mode depending on the traffic loads, thus saving power.

2) Switching Paradigms:

a) Converged Packet-Circuit Switching: Hybrid packet-circuit optical network infrastructures controlled by SDN

have been explored in a few studies. Das et al. [173] have described how to unify the control and management of circuit- and packet-switched networks using OpenFlow. Since packet- and circuit-switched networking are extensively employed in optical networks, examining their integration is an important research direction. Das et al. have given a high-level overview of a flow abstraction for each type of switched network and a common control paradigm. In their follow-up work, Das et al. [174] have described how a packet and circuit switching network can be implemented in the context of an OpenFlow-protocol based testbed. The testbed is a standard Ethernet network that could generally be employed in any access network with Time Division Multiplexing (TDM). Veisllari et al. [175] studied packet/circuit hybrid optical long-haul metro access networks. Although Veisllari et al. indicated that SDN can be used for load balancing in the proposed packet/circuit network, no detailed study of such an SDN-based load balancing has been conducted in [175]. Related switching paradigms that integrate SDN with Generalized Multiple Protocol Label Switching (GMPLS) have been examined in [176], [177], while data center specific aspects have been surveyed in [178].

Cerroni et al. [179] have further developed the concept of unifying circuit- and packet-switching networks with OpenFlow, which was initiated by Das et al. [173], [174]. The unification is accomplished with SDN on the network layer and can be used in core networks. Specifically, Cerroni et al. [179] have described an extension of the OpenFlow flow concept to support hybrid networks. OpenFlow message format extensions to include matching rules and flow entries have also been provided. The matching rules can represent different transport functions, such as a channel on which a packet is received in optical circuit-switched WDM networks, time slots in TDM networks, or transport class services (such as guaranteed circuit service or best effort packet service). Cerroni et al. [179] have presented a testbed setup and reported performance results for throughput (in bit/s and packets/s) to demonstrate the feasibility of the proposed unified OpenFlow switching network.

b) R-LR-UFAN: The Reconfigurable Long-Reach Ultra-Flow Access Network (R-LR-UFAN) [180], [181] provides flexible dual-mode transport service based on either the Internet Protocol (IP) or Optical Flow Switching (OFS). OFS [213] provides dedicated end-to-end network paths through purely optical switching, i.e., there is no electronic processing or buffering at intermediate network nodes. The R-LR-UFAN architecture employs multiple feeder fibers to form subnets within the network. UltraFlow coexists alongside the conventional PON OLT and ONUs. The R-LR-UFAN introduces new entities, namely the Optical Flow Network Unit (OFNU) and the SDN-controlled Optical Flow Line Terminal (OFLT). A Quasi-PAssive Reconfigurable (QPAR) node [182] is introduced between the OFNU and OFLT. The QPAR node can re-route intra PON traffic between OFNUs without having to pass through the OLFs. The optically rerouted intra-PON channels can be used for communication between wireless base stations supporting inter cell device-to-device communication. The testbed evaluations indicate that for an intra-PON traffic ratio of 0.3, the QPAR strategy achieves power savings up to 24%.

c) Flexi-grid: The principle of flexi-grid (elastic) optical networking [30], [88]–[93] has been explored in several SDN infrastructure studies. Generally, flexi-grid networking strives to enhance the efficiency of the optical transmissions by adapting physical (photonic) transmission parameters, such as modulation format, symbol rate, number and spacing of subcarrier wavelength channels, as well as the ratio of forward error correction to payload. Flexi-grid transmissions have become feasible with high-capacity flexible transceivers. Flexi-grid transmissions use narrower frequency slots (e.g., 12.5 GHz) than classical Wavelength Division Multiplexing (WDM, with typically 50 GHz frequency slots for WDM) and can flexibly form optical transmission channels that span multiple contiguous frequency slots.

Cvijetic [183] has proposed a hierarchical flexi-grid infrastructure for multiservice broadband optical access utilizing centralized software-reconfigurable resource management and digital signal processing. The proposed flexi-grid infrastructure incorporates mobile backhaul, as well as SDN controlled transceivers III-A. In follow-up work, Cvijetic et al. [184] have designed a dynamic flexi-grid optical access and aggregation network. They employ SDN to control tunable lasers in the OLT for flexible downstream transmissions. Flexi-grid wavelength selective switches are controlled through SDN to dynamically tune the passband for the upstream transmissions arriving at the OLT. Cvijetic et al. [184] obtained good results for the upstream and downstream bit error rate and were able to provide 150 Mb/s per wireless network cell.

Oliveira et al. [185] have demonstrated a testbed for a Reconfigurable Flexible Optical Network (RFON), which was one of the first physical layer SDN-based testbeds. The RFON testbed is comprised of 4 ROADMs with flexi-grid Wavelength Selective Switching (WSS) modules, optical amplifiers, optical channel monitors and supervisor boards. The controller daemon implements a node abstraction layer and provides configuration details for an overall view of the network. Also, virtualization of the GMPLS control plane with topology discovery and Traffic Engineering (TE)-link instantiation have been incorporated. Instead of using OpenFlow, the RFON testbed uses the controller language YANG [214] to obtain the topology information and collect monitoring data for the lightpaths.

Zhao et al. [186] have presented an architecture with OpenFlow-based optical interconnects for intra-data center networking and OpenFlow-based flexi-grid optical networks for inter-data center networking. Zhao et al. focus on the SDN benefits for inter-data center networking with heterogeneous networks. The proposed architecture includes a service controller, an IP controller, an and optical controller based on the Father Network Operating System (F-NOX) [215], [216]. The performance evaluations in [186] include results for blocking probability, release latency, and bandwidth spectrum characteristics.

D. Optical Performance Monitoring

1) Cognitive Network Infrastructure: A Cognitive Heterogeneous Reconfigurable Dynamic Optical Network (CHRON)

architecture has been outlined in [187]. CHRON senses the current network conditions and adapts the network operation accordingly. The three main components of CHRON are monitoring elements, software adaptable elements, and cognitive processes. The monitoring elements observe two main types of optical transmission impairments, namely non-catastrophic impairments and catastrophic impairments. Non-catastrophic impairments include the photonic impairments that degrade the Optical Signal to Noise Ratio (OSNR), such as the various forms of dispersion, cross-talk, and non-linear propagation effects, but do not completely disrupt the communication. In contrast, a catastrophic impairment, such as a fiber cut or malfunctioning switch, can completely disrupt the communication. Advances in optical performance monitoring allow for in-band OSNR monitoring [217]–[220] at midpoints in the communication path, e.g., at optical amplifiers and ROADMs.

The cognitive processes involve the collection of the monitoring information in the controller, executing control algorithms, and instructing the software adaptable components to implement the control decisions. SDN can provide the framework for implementing these cognitive processes. Two main types of software adaptable components have been considered so far [188], [189], namely control of transceivers and control of wavelength selective switches/amplifiers. For transceiver control, the cognitive control adjusts the transmission parameters. For instance, transmission bit rates can be adjusted through varying the modulation format or the number of signal carriers in multicarrier communication (see Section III-A).

2) *Wavelength Selective Switch/Amplifier Control*: In general, ROADMs (see Section III-C1a) employ wavelength selective switches based on filters to add or drop wavelength channels for routing through an optical network. Detrimental non-ideal filtering effects accumulate and impair the OSNR [191]. At the same time, Erbium Doped Fiber Amplifiers (EDFAs) [221] are widely deployed in optical networks to boost optical signal power that has been depleted through attenuation in fibers and ROADMs. However, depending on their operating points, EDFAs can introduce significant noise. Moura et al. [190] have explored SDN based adaptation strategies for EDFA operating points to increase the OSNR. In a complementary study, Paolucci et al. [191] have exploited SDN control to reduce the detrimental filtering effects. Paolucci group wavelength channels that jointly traverse a sequence of filters at successive switching nodes. Instead of passing these wavelength channels through individual (per-wavelength channel) filters, the group of wavelength channels is jointly passed through a superfilter that encompasses all grouped wavelength channels. This joint filtering significantly improves the OSNR.

While the studies [190], [191] have focused on either the EDFA or the filters, Carvalho et al. [192] and Wang et al. [193] have jointly considered the EDFA and filter control. More specifically, the EDFA gain and the filter attenuation (and signal equalization) profile were adapted to improve the OSNR. Carvalho et al. [192] propose and evaluate a specific joint EDFA and filter optimization approach that exploits the global perspective of the SDN controller. The global optimization

achieves OSNR improvements close to 5 dB for a testbed consisting of four ROADMs with 100 km fiber links. Wang et al. [193] explore different combinations of EDFA gain control strategies and filter equalization strategies for a simulated network with 14 nodes and 100 km fiber links. They find mutual interactions between the EDFA gain control and the filter equalization control as well as an additional wavelength assignment module. They conclude that global SDN control is highly useful for synchronizing the EDFA gain and filter equalization in conjunction with wavelength assignments so as to achieve improved OSNR.

E. Infrastructure Layer: Summary and Discussion

The research to date on the SDN controlled infrastructure layer has resulted in a variety of SDN controlled transceivers as well as a few designs of SDN controlled switching elements. Moreover, the SDN control of switching paradigms and optical performance monitoring have been examined. The SDN infrastructure studies have paid close attention to the physical (photonic) communication aspects. Principles of isolation of control plane and data plane with the goals of simplifying network management and making the networks more flexible have been explored. The completed SDN infrastructure layer studies have indicated that the SDN control of the infrastructure layer can reduce costs, facilitate flexible reconfigurable resource management, increase utilizations, and lower latency. However, detailed comprehensive optimizations of the infrastructure components and paradigms that minimize capital and operational expenditures are an important area for future research. Also, further refinements of the optical components and switching paradigms are needed to ease the deployment of SDONs and make the networks operating on the SDON infrastructures more efficient. Moreover, the cost reduction of implementations, easy adoption by network providers, flexible upgrades to adopt new technologies, and reduced complexity require thorough future research.

Most SDON infrastructure studies have focused on a particular network component or networking aspect, e.g., a transceiver or the hybrid packet-circuit switching paradigm, or a particular application context, e.g., data center networking. Future research should comprehensively examine SDON infrastructure components and paradigms to optimize their interactions for a wide set of networking scenarios and application contexts.

The SDON infrastructure studies to date have primarily focused on the optical transmission medium. Future research should explore complementary infrastructure components and paradigms to support transmissions in hybrid fiber-wireless and other hybrid fiber-*X* networks, such as fiber-Digital Subscriber Line (DSL) or fiber-coax cable networks [109], [222], [223]. Generally, the flexible SDN control can be very advantageous for hybrid networks composed of heterogeneous network segments. The OpenFlow protocol can facilitate the topology abstraction of the heterogeneous physical transmission media, which in turn facilitates control and optimization at the higher network protocol layers.

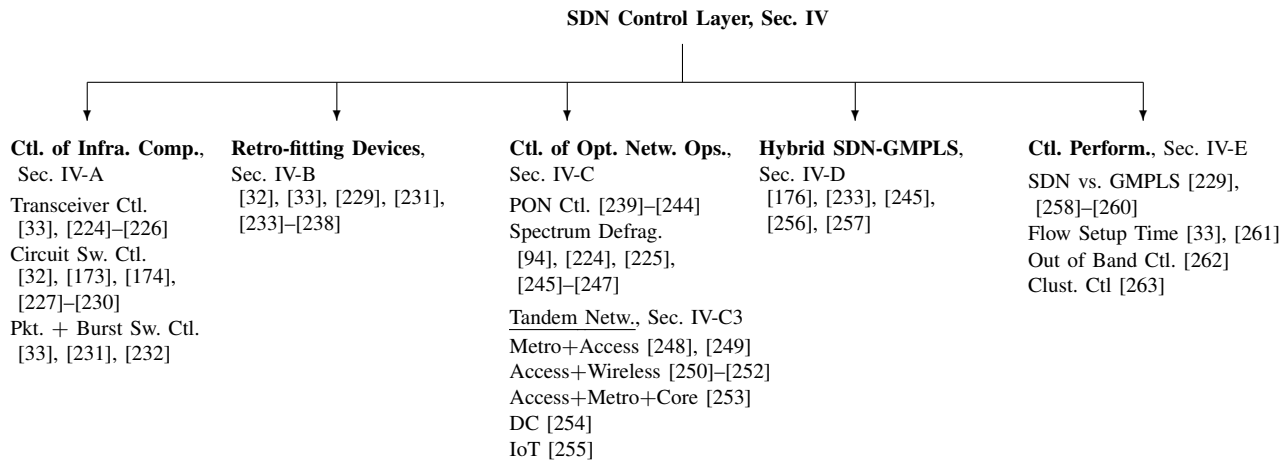

Fig. 6. Classification of SDON control layer studies.

IV. SDN CONTROL LAYER

This section surveys the SDON studies that are focused on applying the SDN principles at the SDN control layer to control the various optical network elements and operational aspects. The main challenges of SDON control include extensions of the OpenFlow protocol for specifically controlling the optical transmission and switching components surveyed in Section III and for controlling the optical spectrum as well as for controlling optical networks spanning multiple optical network tiers (see Section II-D2). As illustrated in Fig. 6, we first survey SDN control mechanisms and frameworks for controlling infrastructure layer components, namely transceivers as well as optical circuit, packet, and burst switches. More specifically, we survey OpenFlow extensions for controlling the optical infrastructure components. We then survey mechanisms for retro-fitting non-SDN optical network elements so that they can be controlled by OpenFlow. The retro-fitting typically involves the insertion of an abstraction layer into the network elements. The abstraction layer makes the optical hardware controllable by OpenFlow. The retro-fitting studies would also fit into Section III as the abstraction layer is inserted into the network elements; however, the abstraction mechanisms closely relate to the OpenFlow extensions for optical networking and we include the retro-fitting studies therefore in this control layer section. We then survey the various SDN control mechanisms for operational aspects of optical networks, including the control of tandem networks that include optical segments. Lastly, we survey SDON controller performance analysis studies.

A. SDN Control of Optical Infrastructure Components

1) *Controlling Optical Transceivers with OpenFlow*: Recent generations of optical transceivers utilize digital signal processing techniques that allow many parameters of the transceiver to be software controlled, see Sections III-A1 and III-A2. These parameters include modulation scheme, symbol rate, and wavelength. Yu et al. [224] and Chen et al. [225] proposed adding a “modulation format” field to the OpenFlow cross-connect table entries to support this programmable feature of some software defined optical transceivers.

Ji et al. [226] created a testbed that places super-channel optical transponders and optical amplifiers under SDN control. An OpenFlow extension is proposed to control these devices. The modulation technique and FEC code for each optical subcarrier of the super-channel transponder and the optical amplifier power level can be controlled via OpenFlow. Ji et al. do not discuss this explicitly but the transponder subcarriers can be treated as OpenFlow switch ports that can be configured through the OpenFlow protocol via port modification messages. It is unclear in [226] how the amplifiers would be controlled via OpenFlow. However, doing so would allow the SDN controller to adaptively modify amplifiers to compensate for channel impairments while minimizing energy consumption. Ji et al. [226] have established a testbed demonstrating the placement of transponders and EDFA optical amplifiers under SDN control.

Liu et al. [33] propose configuring optical transponder operation via flow table entries with new transponder specific fields (without providing details). They also propose capturing failure alarms from optical transponders and sending them to the SDN controller via OpenFlow Packet-In messages. These messages are normally meant to establish new flow connections. Alternatively, a new OpenFlow message type could be created for the purpose of capturing failure alarms [33]. With failure alarm information, the SDN controller can implement protection switching services.

2) *Controlling Optical Circuit Switches with OpenFlow*: Circuit switching can be enabled by OpenFlow by adding new circuit switching flow table entries [173], [174], [227], [230]. The OpenFlow circuit switching addendum [228] discusses the addition of cross-connect tables for this purpose. These cross-connect tables are configured via OpenFlow messages inside the circuit switches. According to the addendum, a cross-connect table entry consists of the following fields to identify the input:

- Input Port
- Input Wavelength
- Input Time Slot
- Virtual Concatenation Group

and the following fields to identify the output:

- Output Port

- Output Wavelength
- Output Time Slot
- Virtual Concatenation Group

These cross-connect tables cover circuit switching in space, fixed-grid wavelength, and time.

Channegowda et al. [32], [229] extend the capabilities of the OpenFlow circuit switching addendum to support flexible wavelength grid optical switching. Specifically, the wavelength identifier specified in the circuit switching addendum to OpenFlow, is replaced with two fields: *center frequency*, and *slot width*. The *center frequency* is an integer specifying the multiple of 6.25GHz the center frequency is away from 193.1Thz and the *slot width* is a positive integer specifying the spectral width in multiples of 12.5GHz.

An SDN controlled optical network testbed at the University of Bristol has been established to demonstrate the OpenFlow extensions for flexible grid DWDM [32]. The testbed consists of both fixed-grid and flexible-grid optical switching devices. South Korea Telekom has also built an SDN controlled optical network testbed [264].

3) *Controlling Optical Packet and Burst Switches with OpenFlow*: OpenFlow flow tables can be utilized in optical packet switches for expressing the forwarding table and its computation can be offloaded to an SDN controller. This offloading can simplify the design of highly complex optical packet switches [231].

Cao et al. [231] extend the OpenFlow protocol to work with Optical Packet Switching (OPS) devices by creating: (i) an abstraction layer that converts OpenFlow configuration messages to the native OPS configuration, (ii) a process that converts optical packets that do not match a flow table entry to the electrical domain for forwarding to the SDN controller, and (iii) a wavelength identifier extension to the flow table entries. To compensate for either the lack of any optical buffering or limited optical buffering, an SDN controller, with its global view, can provide more effective means to resolve contention that would lead to packet loss in optical packet switches. Specifically, Cao et al. suggest to select the path with the most available resources among multiple available paths between two nodes [231]. Paths can be re-computed periodically or on-demand to account for changes in traffic conditions. Monitoring messages can be defined to keep the SDN controller updated of network traffic conditions.

Engineers with Japan's National Institute of Information and Communications Technology [232] have created an optical circuit and packet switched demonstration system in which the packet portion is SDN controlled. The optical circuit switching is implemented with Wavelength Selective Switches (WSSs) and the optical packet switching is implemented with an Semiconductor Optical Amplifier (SOA) switch.

OpenFlow flow tables can also be used to configure optical burst switching devices [33]. When there is no flow table entry for a burst of packets the optical burst switching device can send the Burst Header Packet (BHP) to the SDN controller to process the addition of the new flow to the network [33] rather than the first packet in the burst.

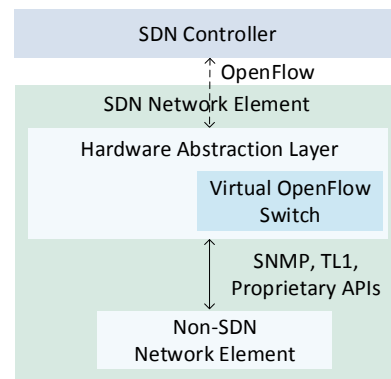

Fig. 7. Traditional non-SDN network elements can be retro-fitted for control by an SDN controller using OpenFlow using a hardware abstraction layer [33], [234]–[237].

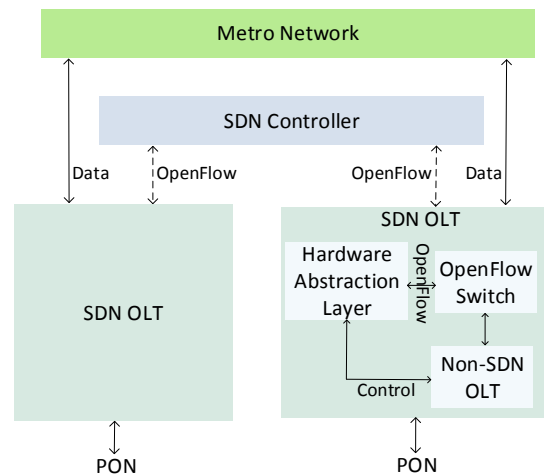

Fig. 8. Non-SDN OLTs can be retro-fitted for control by an SDN controller using OpenFlow [238].

B. Retro-fitting Devices to Support OpenFlow

An abstraction layer can be used to turn non-SDN optical switching devices into OpenFlow controllable switching devices [32], [33], [229], [231], [233]. As illustrated in Fig. 7, the abstraction layer provides a conversion layer between OpenFlow configuration messages and the optical switching devices' native management interface, e.g., the Simple Network Management Protocol (SNMP), the Transaction Language 1 (TL1) protocol, or a proprietary (vendor-specific) API. Additionally, a virtual OpenFlow switch with virtual interfaces that correspond to physical switching ports on the non-SDN switching device completes the abstraction layer [33], [234]–[237]. When a flow entry is added between two virtual ports in the virtual OpenFlow switch, the abstraction layer uses the switching devices' native management interface to add the flow entry between the two corresponding physical ports.

A non-SDN PON OLT can be supplemented with a two-port OpenFlow switch and a hardware abstraction layer that converts OpenFlow forwarding rules to control messages understood by the non-SDN OLT [238]. Figure 8 illustrates this OLT retro-fit for SDN control via OpenFlow. In this way the PON has its switching functions controlled by OpenFlow.

C. SDN Control of Optical Network Operation

1) Controlling Passive Optical Networks with OpenFlow:

An SDN controlled PON can be created by upgrading OLTs to SDN-OLTs that can be controlled using a Southbound Interface, such as OpenFlow [239], [240]. A centralized PON controller, potentially executing in a data center, controls one or more SDN-OLTs. The advantage of using SDN is the broadened perspective of the PON controller as well as the potentially reduced cost of the SDN-OLT compared to a non-SDN OLT.

Parol and Pawlowski [241], [242] define OpenFlowPLUS to extend the OpenFlow SBI for GPON. OpenFlowPLUS extends SDN programmability to both OLT and ONU devices whereby each act as an OpenFlow switch through a programmable flow table. Non-switching functions (e.g., ONU registration, dynamic bandwidth allocation) are outside the scope of OpenFlowPLUS. OpenFlowPLUS extends OpenFlow by channeling OpenFlow messages through the GPON ONU Management and Control Interface (OMCI) control channel and adding PON specific action instructions to flow table entries. The PON specific action instructions defined in OpenFlowPLUS are:

- (new *gpon* action type): map matching packets to PON specific traffic identifiers, e.g., GPON Encapsulation Method (GEM) ports and GPON Traffic CONTainers (T-CONTs)
- (*output* action type): activate PON specific framing of matching packets

Many of the OLT functions operate at timescales that are problematic for the controller due to the latency between the controller and OLTs. However, Khalili et al. [239] identify ONU registration policy and coarse timescale DBA policy as functions that operate at timescales that allow effective offloading to an SDN controller. Yan et al. [243] further identify OLT and ONU power control for energy savings as a function that can be effectively offloaded to an SDN controller.

There is also a movement to use PONs in edge networks to provide connectivity inside a multitenant building or on a campus with multiple buildings [241], [242]. The use of PONs in this edge scenario requires rapid re-provisioning from the OLT. A software controlled PON can provide this needed rapid re-provisioning [241], [242].

Kanonakis, Cvijetic, et al. [244] propose leveraging the broad perspective that SDN can provide to perform dynamic bandwidth allocation across several Virtual PONs (VPONs). The VPONs are separated on a physical PON by the wavelength bands that they utilize. Bandwidth allocation is performed at the granularity of OFDMA subcarriers that compose the optical spectrum.

2) *SDN Control of Optical Spectrum Defragmentation*: In a departure from the fixed wavelength grid (ITU-T G.694.1), elastic optical networking allows flexible use of the optical spectrum. This flexibility can permit higher spectral efficiency by avoiding consuming an entire fixed-grid wavelength channel when unnecessary and avoiding unnecessary guard bands in certain circumstances [94]. However, this flexibility causes fragmentation of the optical spectrum as flexible grid

lightpaths are established and terminated over time.

Spectrum fragmentation leads to the circumstance in which there is enough spectral capacity to satisfy a demand but that capacity is spread over several fragments rather than being consolidated in adjacent spectrum as required. If the fragmentation is not counter-acted by a periodic defragmentation process than overall spectral utilization will suffer. This resource fragmentation problem appears in computer systems in main memory and long term storage. In those contexts the problem is typically solved by allowing the memory to be allocated using non-adjacent segments. Memory and storage is partitioned into pages and blocks, respectively. The allocations of pages to a process or blocks to a file do not need to be contiguous. With communication spectrum this would mean combining multiple small bandwidth channels through inverse multiplexing to create a larger channel [245].

An SDN controller can provide a broad network perspective to empower the periodic optical spectrum defragmentation process to be more effective [245]. In general, optical spectrum defragmentation operations can reduce lightpath blocking probabilities from 3% [224] up to as much as 75% [225], [246]. Multicore fibers provide additional spectral resources through additional transmission cores to permit quasi-hitless defragmentation [247].

3) SDN Control of Tandem Networks:

a) *Metro and Access*: Wu et al. [248], [249] propose leveraging the broad perspective that SDN can provide to improve bandwidth allocation. Two cooperating stages of SDN controllers: (i) access stage that controls each SDN OLT individually, and (ii) metro stage that controls global bandwidth allocation strategy, can coordinate bandwidth allocation across several physical PONs [248], [249]. The bandwidth allocation is managed cooperatively among the two stages of SDN controllers to optimize the utilization of the access and metro network bandwidth. Simulation experiments indicate a 40% increase in network bandwidth utilization as a result of the global coordination compared to operating the bandwidth allocation only within the individual PONs [248], [249].

b) *Access and Wireless*: Bojic, Cvijetic, et al. [250] expand on the concept of SDN controlled OFDMA enabled VPONs [244] to provide mobile backhaul service. The backhaul service can be provided for wireless small-cell sites (e.g., micro and femto cells) that utilize millimeter wave frequencies. Each small-cell site contains an OFDMA-PON ONU that provides the backhaul service through the access network over a VPON. An SDN controller is utilized to assign bandwidth to each small-cell site through OFDMA subcarrier assignment in a VPON to the constituent ONU. The SDN controller leverages its broad view of the network to provide solutions to the joint bandwidth allocation and routing across several network segments. With this broad perspective of the network, the SDN controller can make globally rather than just locally optimal bandwidth allocation and routing decisions. Efficient optimization algorithms, such as genetic algorithms, can be used to provide computationally efficient competitive solutions, mitigating computational complexity issues associated with optimization for large networks. Additionally, network partitioning with an SDN controller for each partition

can be used to mitigate unreasonable computational complexity that arises when scaling to large networks. Tanaka and Cvijetic [251] presented one such optimization formulation for maximizing throughput.

Costa-Requena et al. [252] described a proof-of-concept LTE testbed they have constructed whereby the network consists of software defined base stations and various network functions executing on cloud resources. The testbed is described in broad qualitative terms, no technical details are provided. There was no mathematical or experimental analysis provided.

c) Access, Metro, and Core: Slyne and Ruffini [253] provide a use case for SDN switching control across network segments: use Layer 2 switching across the access, metro, and core networks. Layer 2 (e.g., Ethernet) switching does not scale well due to a lack of hierarchy in its addresses. That lack of hierarchy does not allow for switching rules on aggregates of addresses thereby limiting the scaling of these networks. Slyne and Ruffini [253] propose using SDN to create hierarchical pseudo-MAC addresses that permit a small number of flow table entries to configure the switching of traffic using Layer 2 addresses across network segments. The pseudo-MAC addresses encode information about the device location to permit simple switching rules. At the entry of the network, flow table entries are set up to translate from real (non-hierarchical) MAC addresses to hierarchical pseudo-MAC addresses. The reverse takes place at the exit point of the network.

d) DC Virtual Machine Migration: Mandal et al. [254] provided a cloud computing use case for SDN bandwidth allocation across network segments: Virtual Machine (VM) migration between data centers. VM migrations require significant network bandwidth. Bandwidth allocation that utilizes the broad perspective that SDN can provide is critical for reasonable VM migration latencies without sacrificing network bandwidth utilization.

e) Internet of Things: Wang et al. [255] examine another use case for SDN bandwidth allocation across network segments: the Internet of Things (IoT). Specifically, Wang et al. have developed a Dynamic Bandwidth Allocation (DBA) protocol that exploits SDN control for multicasting and suspending flows. This DBA protocol is studied in the context of a virtualized WDM optical access network that provides IoT services through the distributed ONUs to individual devices. The SDN controller employs multicasting and flow suspension to efficiently prioritize the IoT service requests. Multicasting allows multiple requests to share resources in the central nodes that are responsible for processing a prescribed wavelength in the central office (OLT). Flow suspension allows high-priority requests (e.g., an emergency call) to suspend ongoing low-priority traffic flows (e.g., routine meter readings). Performance results for a real-time SDN controller implementation indicate that the proposed bandwidth (resource) allocation with multicast and flow suspension can improve several key performance metrics, such as request serving ratio, revenue, and delays by 30–50 % [255].

D. Hybrid SDN-GMPLS Control

1) Generalized MultiProtocol Label Switching (GMPLS): Prior to SDN, MultiProtocol Label Switching (MPLS) offered a mechanism to separate the control and data planes through label switching. With MPLS, packets are forwarded in a connection-oriented manner through Label Switched Paths (LSPs) traversing Label Switching Routers (LSRs). An entity in the network establishes an LSP through a network of LSRs for a particular class of packets and then signals the label-based forwarding table entries to the LSRs. At each hop along an LSP, a packet is assigned a label that determines its forwarding rule at the next hop. At the next hop, that label determines that packet's output port and label for the next hop; the process repeats until the packet reaches the end of the LSP. Several signalling protocols for programming the label-based forwarding table entries inside LSRs have been defined, e.g., through the Resource Reservation Protocol (RSVP). Generalized MPLS (GMPLS) extends MPLS to offer circuit switching capability. Although never commercially deployed [33], GMPLS and a centralized Path Computation Element (PCE) [265]–[268] have been considered for control of optical networks.

2) Path Computation Element (PCE): A PCE is a concept developed by the IETF (see RFC 4655) to refer to an entity that computes network paths given a topology and some criteria. The PCE concept breaks the path computation action from the forwarding action in switching devices. A PCE could be distributed in every switching element in a network domain or there could be a single centralized PCE for an entire network domain. The network domain could be an area of an Autonomous System (AS), an AS, a conglomeration of several ASes, or just a group of switching devices relying on one PCE. Some of an SDN controller's functionality falls under the classification of a centralized PCE. However, the PCE concept does not include the external configuration of forwarding tables. Thus, a centralized PCE device does not necessarily have a means to configure the switching elements to provision a computed path.

When the entity requesting path computation is not collocated with the PCE, a PCE Communication Protocol (PCEP) is used over TCP port 4189 to facilitate path computation requests and responses. The PCEP consists of the following message types:

- Session establishment messages (open, keepalive, close)
- PCReq – Path computation request
- PCRep – Path computation reply
- PCNtf – event notification
- PCErr – signal a protocol error

The path computation request message must include the end points of the path and can optionally include the requested bandwidth, the metric to be optimized in the path computation, and a list of links to be included in the path. The Path computation reply includes the computed path expressed in the Explicit Route Object format (see RFC 3209) or an indication that there is no path. See RFC 5440 for more details on PCEP.

A PCE has been proposed as a central entity to manage a GMPLS-enabled optical circuit switched network. Specifi-

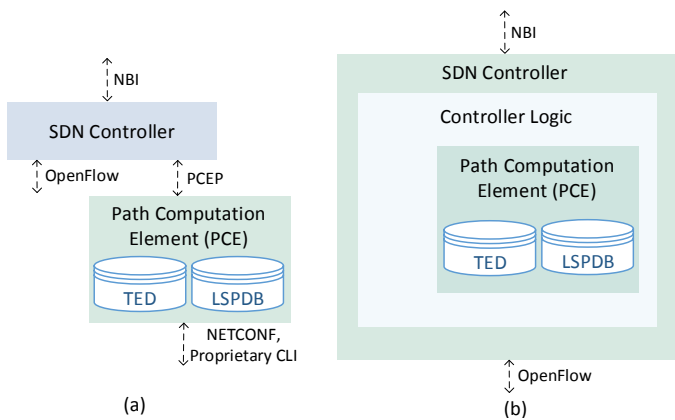

Fig. 9. Hybrid GMPLS/PCE and SDN network control: (a) SDN controller utilizes a PCE to control a portion of the network [176], [245] through the NETCONF protocol or a proprietary command line interface (CLI). (b) SDN controller utilizes the path computation ability of the PCE [233], [256], [257] and controls network through OpenFlow protocol.

ally, the PCE maintains the network topology in a structure called the Traffic Engineering Database (TED). The traffic engineering modifier (see RFC 2702) signifies that the path computations are made to relieve congestion that is caused by the sub-optimal allocation of network resources. This modifier is used extensively in discussions of MPLS/GMPLS because their use case is for traffic engineering; in acronym form the modifier is TE (e.g., TE LSP, RSVP-TE).

If the PCE is stateful with complete control over its network domain, it will also maintain an LSP database recording the provisioned GMPLS lightpaths. A lightpath request can be sent to the PCE, it will use the topology and LSP database to find the optimal path and then configure the GMPLS-controlled optical circuit switching nodes using NETCONF (see RFC 6241) or proprietary command line interfaces (CLIs) [245]. This stateful PCE with instantiation capabilities (capabilities to provision lightpaths) operates similarly to an SDN controller. For that reason, GMPLS with a centralized stateful PCE with instantiation capabilities can provide a baseline for performance analysis of an SDN controller as well as provide a mechanism to be blended with an SDN controller for hybrid control [32], [229], [233].

3) *Approaches to Hybrid SDN-GMPLS Control*: Hybrid GMPLS/PCE and SDN control can be formed by allowing an SDN controller to leverage a centralized PCE to control a portion of the infrastructure using PCEP as the SBI [176], [245]; see illustration a) in Figure 9. The SDN controller builds higher functionality above what the PCE provides and can possibly control a large network that utilizes several PCEs as well as OpenFlow controlled network elements.

Alternatively, the SDN controller can leverage a PCE for its path computation abilities with the SDN controller handling the configuration of the network elements to establish a path using an SBI protocol, such as OpenFlow [233], [256], [257]; see illustration b) in Figure 9.

E. SDN Performance Analysis

1) *SDN vs. GMPLS*: Liu et al. [258] provided a qualitative comparison of GMPLS, GMPLS/PCE, and SDN OpenFlow

for control of wavelength switched optical networks. Liu et al. noted that there is an evolution of centralized control from GMPLS to GMPLS/PCE to OpenFlow. Whereas GMPLS offers distributed control, GMPLS/PCE is commonly regarded as having centralized path computation but still distributed provisioning/configuration; while OpenFlow centralizes all of the network control. In our discussion in Section IV-D we noted that a stateful PCE with instantiation capabilities centralizes all network control and is therefore very similar to SDN. Liu et al. have also pointed out that GMPLS/PCE is more technically mature compared to OpenFlow with IETF RFCs for GMPLS (see RFC 3471) and PCE (see RFC 4655) that date back to 2003 and 2006, respectively. SDN has just recently, in 2014, received standardization attention from the IETF (see RFC 7149).

A comparison of GMPLS and OpenFlow has been conducted by Zhao et al. [259] for large-scale optical networks. Two testbeds were built, based on GMPLS and on Openflow, respectively. Performance metrics, such as blocking probability, wavelength utilization, and lightpath setup time were evaluated for a 1000 node topology. The results indicated that GMPLS gives slightly lower blocking probability. However, OpenFlow gives higher wavelength utilization and shorter average lightpath setup time. Thus, the results suggest that OpenFlow is overall advantageous compared to GMPLS in large-scale optical networks.

Cvijetic et al. [260] conducted a numerical analysis to compare the computed shortest path lengths for non-SDN, partial-SDN, and full-SDN optical networks. A full-SDN network enables path lengths that are approximately a third of those computed on a non-SDN network. These path lengths can also translate into an energy consumption measure, with shortest paths resulting in reduced energy consumption. An SDN controlled network can result in smaller computed shortest paths that translates to smaller network latency and energy consumption [260].

Experiments conducted on the testbed described in [229] show a 4 % reduction in lightpath blocking probability using SDN OpenFlow compared to GMPLS for lightpath provisioning. The same experiments show that lightpath setup times can be reduced to nearly half using SDN OpenFlow compared to GMPLS. Finally, the experiments show that an OpenvSwitch based controller can process about three times the number of flows per second as a NOX [215] based controller.

2) *SDN Controller Flow Setup*: Veisllari et al. [261] evaluated the use of SDN to support both circuit and packet switching in a metropolitan area ring network that interconnects access network segments with a backbone network. This network is assumed to be controlled by a single SDN controller. The objective of the study [261] was to determine the effect of packet service flow size on the required SDN controller flow service time to meet stability conditions at the controller. Toward this end, Veisllari et al. produced a mean arrival rate function of new packet and circuit flows at that controller. This arrival rate function was visualized by varying the length of short-lived (“mice”) flows, the fraction of long-lived (“elephant”) flows, and the volume of traffic consumed by “elephant” flows. Veisllari et al. discovered,

through these visualizations, that the length of “mice” flows is the dominating parameter in this model.

Veisllari et al. translated the arrival rate function analysis to an analysis of the ring MAN network dimensions that can be supported by a single SDN controller. The current state-of-the-art Beacon controller can handle a flow request every 571 ns. Assuming mice flows sizes of 20 kB and average circuit lifetimes of 1 second, as the fraction of packet traffic increases from 0.1 to 0.9, the network dimension supported by a single Beacon SDN controller decreases from 14 nodes with 92 wavelengths per node to 5 nodes with 10 wavelengths per node.

Liu et al. [33] use a multinational (Japan, China, Spain) NOX:OpenFlow controlled four-wavelength optical circuit and burst switched network to study path setup/release times as well as path restoration times. The optical transponders that can generate failure alarms were also under NOX:OpenFlow control and these alarms were used to trigger protection switching. The single SDN controller was located in the Japanese portion of the network. The experiments found the path setup time to vary from 250–600 ms and the path release times to vary from 130–450 ms. Path restoration times varied from 250–500 ms. Liu et al. noted that the major contributing factor to these times was the OpenFlow message delivery time [33].

3) *Out of Band Control*: Sanchez et al. [262] have qualitatively compared four SDN controlled ring metropolitan network architectures. The architectures vary in whether the SDN control traffic is carried in-band with the data traffic or out-of-band separately from the data traffic. In a single wavelength ring network, out-of-band control would require a separate physical network that would come at a high cost, but provide reliability of the network control under failure of the ring network. In a multiwavelength ring network, a separate wavelength can be allocated to carry the control traffic. Sanchez et al. [262] focused on a Tunable Transceiver Fixed Receiver (TTFR) WDM ring node architecture. In this architecture each node receives data on a home wavelength channel and has the capability to transmit on any of the available wavelengths to reach any other node. The addition of the out-of-band control channel on a separate wavelength requires each node to have an additional fixed receiver, thereby increasing cost. Sanchez et al. identified a clear tradeoff between cost and reliability when comparing the four architectures.

4) *Clustered SDN Control*: Penna et al. [263] described partitioning a wavelength-switched optical network into administrative domains or clusters for control by a single SDN controller. The clustering should meet certain performance criteria for the SDN controller. To permit lightpath establishment across clusters, an inter-cluster lightpath establishment protocol is established. Each SDN controller provides a lightpath establishment function between any two points in its associated cluster. Each SDN controller also keeps a global view of the network topology. When an SDN controller receives a lightpath establishment request whose computed path traverses other clusters, the SDN controller requests lightpath establishment within those clusters via a WBI.

The formation of clusters can be performed such that for

a specified number of clusters the average distance to each SDN controller is minimized [263]. The lightpath establishment time decreases exponentially as the number of clusters increases.

F. Control Layer: Summary and Discussion

A very large body of literature has explored how to expand the OpenFlow protocol to support various optical network technologies (e.g., optical circuit switching, optical packet switching, passive optical networks). A significant body of literature has investigated methodologies for retro-fitting non-SDN network elements for OpenFlow control as well as integrating SDN/OpenFlow with the GMPLS/PCE control framework. A variety of SDN controller use cases have been identified that motivate the benefits of the centralized network control made possible with SDN (e.g., bandwidth allocation over large numbers of subscribers, controlling tandem networks).

However, analyzing the performance of SDN controllers for optical network applications is still in a state of infancy. It will be important to understand the connection between the implementation of the SDN controller (e.g., processor core architecture, number of threads, operating system) and the network it can effectively control (e.g., network traffic volume, network size) to meet certain performance objectives (e.g., maximum flow setup time). At present there are not enough relevant studies to gain an understanding of this connection. With this understanding network service providers will be able to partition their networks into control domains in a manner that meets their performance objectives.

V. VIRTUALIZATION

This section surveys control layer mechanisms for virtualizing SDONs. As optical infrastructures have typically high costs, creating multiple VONs over the optical network infrastructure is especially important for access networks, where the costs need to be amortized over relatively few users. Throughout, accounting for the specific optical transmission and signal propagation characteristics is a key challenge for SDON virtualization. Following the classification structure illustrated in Fig. 10, we initially survey virtualization mechanisms for access networks and data center networks, followed by virtualization mechanisms for optical core networks.

A. Access Networks

1) *OFDMA Based PON Access Network Virtualization*: Wei et al. [269]–[271] have developed a link virtualization mechanism that can span from optical access to backbone networks based on Orthogonal Frequency Division Multiplexing Access (OFDMA). Specifically, for access networks, a Virtual PON (VPON) approach based on multicarrier OFDMA over WDM has been proposed. Distinct network slices (VPONs) utilize distinct OFDMA subcarriers, which provide a level of isolation between the VPONs. Thus, different VPONs may operate with different MAC standards, e.g., as illustrated in Fig. 11(a), VPON A may operate as an Ethernet PON

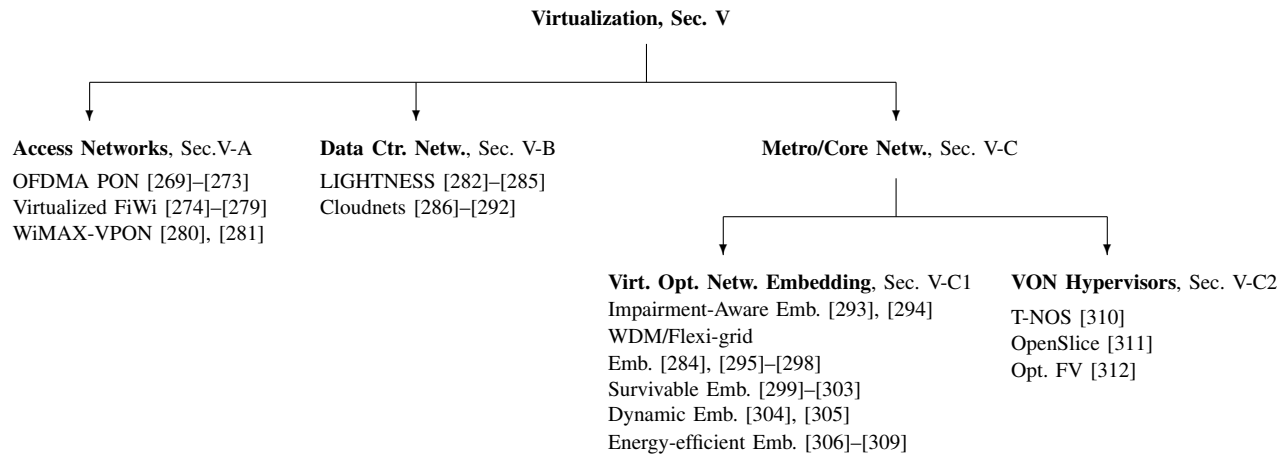

Fig. 10. Classification of SDON virtualization studies.

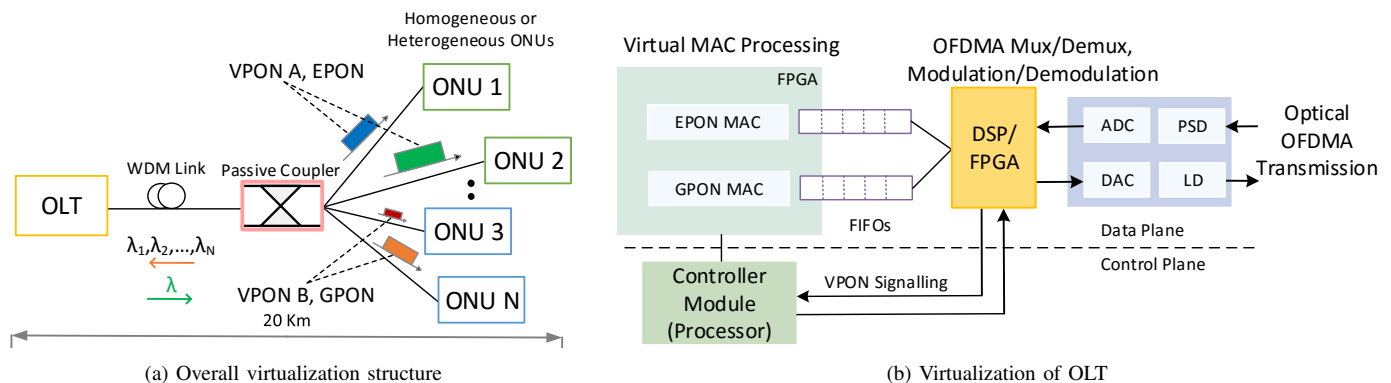

Fig. 11. Illustration of OFDMA based virtual access network [269]: The different VPONs operate on isolated OFDMA sub carriers allowing different MAC standards, such as EPON and GPON, to operate on the same physical PON infrastructure, as illustrated in part (a). A central SDN control module controls the OFDMA transmissions and receptions as well as the virtual MAC processing, see part (b).

(EPON) while VPON B operates as a Gigabit PON (GPON). In addition, virtual MAC queues and processors are isolated to store and process the data from multiple VPONs, thus creating virtual MAC protocols, as illustrated in Fig. 11(b). The OFDMA transmissions and receptions are processed in a DSP module that is controlled by a central SDN control module. The central SDN control module also controls the different virtual MAC processes in Fig. 11(b), which feed/receive data to/from the DSP module. Additional bandwidth partitioning between VPONs can be achieved through Time Division Multiple Access (TDMA). Simulation studies compared a static allocation of subcarriers to VPONs with a dynamic allocation based on traffic demands. The dynamic allocation achieved significantly higher numbers of supported VPONs on a given network infrastructure as well as lower packet delays than the static allocation.

Similar OFDMA based slicing strategies for supporting cloud computing have been examined by Jinno et al. [272]. Zhou et al. [273] have explored a FlexPON with similar virtualization capabilities. The FlexPON employs OFDM for adaptive transmissions. The isolation of different VPONs is mainly achieved through separate MAC processing. The resulting VPONs allow for flexible port assignments in ONUs and OLT, which have been demonstrated in a testbed [273].

2) FiWi Access Network Virtualization:

a) Virtualized FiWi Network: Dai et al. [274]–[276] have examined the virtualization of FiWi networks [313], [314] to eliminate the differences between the heterogeneous segments (fiber and wireless). The virtualization provides a unified homogenous (virtual) view of the FiWi network. The unified network view simplifies flow control and other operational algorithms for traffic transmissions over the heterogeneous network segments. In particular, a virtual resource manager operates the heterogeneous segments. The resource manager permits multiple routes from a given source node to a given destination node. Load balancing across the multiple paths has been examined in [277], [278]. Simulation results indicate that the virtualized FiWi network with load balancing significantly reduces packet delays compared to a conventional FiWi network. An experimental OpenFlow switch testbed of the virtualized FiWi network has been presented in [279]. Testbed measurements demonstrate the seamless networking across the heterogeneous fiber and wireless networks segments. Measurements for nodal throughput, link bandwidth utilization, and packet delay indicate performance improvements due to the virtualized FiWi networking approach. Moreover, the FiWi testbed performance is measured for a video service scenario indicating that the virtualized FiWi networking approach improves the Quality of Experience (QoE) [315], [316] of the video streaming. A mathematical performance model of the virtualized FiWi network has been developed in [279].

b) WiMAX-VPON: WiMAX-VPON [280], [281] is a Layer-2 Virtual Private Network (VPN) design for FiWi access networks. WiMAX-VPON executes a common MAC protocol across the wireless and fiber network segments. A VPN based admission control mechanism in conjunction with a VPN bandwidth allocation ensures per-flow Quality of Service (QoS). Results from discrete event simulations demonstrate that the proposed WiMAX-VPON achieves favorable performance. Also, Dhaini et al. [280], [281] demonstrate how the WiMAX-VPON design can be extended to different access network types with polling-based wireless and optical medium access control.

B. Data Centers

1) LIGHTNESS: LIGHTNESS [282]–[285] is a European research project examining an optical Data Center Network (DCN) capable of providing dynamic, programmable, and highly available DCN connectivity services. Whereas conventional DCNs have rigid control and management platforms, LIGHTNESS strives to introduce flexible control and management through SDN control. The LIGHTNESS architecture comprises server racks that are interconnected through optical packet switches, optical circuit switches, and hybrid Top-of-the-Rack (ToR) switches. The server racks and switches are all controlled and managed by an SDN controller. LIGHTNESS control consists of an SDN controller above the optical physical layer and OpenFlow agents that interact with the optical network and server elements. The SDN controller in cooperation with the OpenFlow-agents provides a programmable data plane to the virtualization modules. The virtualization creates multiple Virtual Data Centers (VDCs), each with its own virtual computing and memory resources, as well as virtual networking resources, based on a given physical data center. The virtualization is achieved through a VDC planner module and an NFV application that directly interact with the SDN controller. The VDC planner composes the VDC slices through mapping of the VDC requests to the physical SDN-controlled switches and server racks. The VDC slices are monitored by the NFV application, which interfaces with the VDC planner. Based on monitoring data, the NFV application and VDC planner may revise the VDC composition, e.g., transition from optical packet switches to optical circuit switches.

2) Cloudnets: Cloudnets [317]–[322] exploit network virtualization for pooling resources among distributed data centers. Cloudnets support the migration of virtual machines across networks to achieve resource pooling. Cloudnet designs can be supported through optical networks [323]. Kantarci and Mouftah [286] have examined designs for a virtual cloud backbone network that interconnects distributed backbone nodes, whereby each backbone node is associated with one data center. A network resource manager periodically executes a virtualization algorithm to accommodate traffic demands through appropriate resource provisioning. Kantarci and Mouftah [286] have developed and evaluated algorithms for three provisioning objectives: minimize the outage probability of the cloud, minimize the resource provisioning, and minimize a tradeoff between resource saving and cloud outage probability.

The range of performance characteristics for outage probability, resource consumption, and delays of the provisioning approaches have been evaluated through simulations. The outage probability of optical cloud networks has been reduced in [287] through optimized service re-locations.

Several complementary aspects of optical cloudnet networks have recently been investigated. A multilayer network architecture with an SDN based network management structure for cloud services has been developed in [288]. A dynamic variation of the sharing of optical network resources for intra- and inter-data center networking has been examined in [289]. The dynamic sharing does not statically assign optical network resources to virtual optical networks; instead, the network resources are dynamically assigned according to the time-varying traffic demands. An SDN based optical transport mode for data center traffic has been explored in [290]. Virtual machine migration mechanisms that take the characteristics of renewable energy into account have been examined in [291] while general energy efficiency mechanisms for optically networked computing resources have been examined in [292].

C. Metro/Core Networks

1) Virtual Optical Network Embedding: Virtual optical network embedding seeks to map requests for virtual optical networks to a given physical optical network infrastructure (substrate). A virtual optical network consists of both a set of virtual nodes and a set of interconnecting links that need to be mapped to the network substrate. This mapping of virtual networks consisting of both network nodes and links is fundamentally different from the extensively studied virtual topology design for optical wavelength routed networks [324], which only considered network links (and did not map nodes). Virtual network embedding of both nodes and link has already been extensively studied in general network graphs [73], [325]. However, virtual optical network embedding requires additional constraints to account for the special optical transmission characteristics, such as the wavelength continuity constraint and the transmission reach constraint. Consequently, several studies have begun to examine virtual network embedding algorithms specifically for optical networks.

a) Impairment-Aware Embedding: Peng et al. [293], [294] have modeled the optical transmission impairments to facilitate the embedding of isolated VONs in a given underlying physical network infrastructure. Specifically, they model the physical (photonic) layer impairments of both single-line rate and mixed-line rates [326]. Peng et al. [294] consider intra-VON impairments from Amplified Spontaneous Emission (ASE) and inter-VON impairments from non-linear impairments and four wave mixing. These impairments are captured in a Q -factor [327], [328], which is considered in the mapping of virtual links to the underlying physical link resources, such as wavelengths and wavebands.

b) Embedding on WDM and Flexi-grid Networks: Zhang et al. [295] have considered the embedding of overall virtual networks encompassing both virtual nodes and virtual links. Zhang et al. have considered both conventional WDM networks as well as flexi-grid networks. For each network type,

they formulate the virtual node and virtual link mapping as a mixed integer linear program. Concluding that the mixed integer linear program is NP-hard, heuristic solution approaches are developed. Specifically, the overall embedding (mapping) problem is divided into a node mapping problem and a link mapping problem. The node mapping problem is heuristically solved through a greedy MinMapping strategy that maps the largest computing resource demand to the node with the minimum remaining computing capacity (a complementary MaxMapping strategy that maps the largest demand to the node with the maximum remaining capacity is also considered). After the node mapping, the link mapping problem is solved with an extended grooming graph [329]. Comparisons for a small network indicate that the MinMapping strategy approaches the optimal mixed integer linear program solution quite closely; whereas the MaxMapping strategy gives poor results. The evaluations also indicate that the flexi-grid network requires only about half the spectrum compared to an equivalent WDM network for several evaluation scenarios.

The embedding of virtual optical networks in the context of elastic flexi-grid optical networking has been further examined in several studies. For a flexi-grid network based on OFDM [30], Zhao et al. [296] have compared a greedy heuristic that maps requests in decreasing order of the required resources with an arbitrary first-fit benchmark. Gong et al. [297] have considered flexi-grid networks with a similar overall strategy of node mapping followed by link mapping as Zhang et al. [295]. Based on the local resource constraints at each node, Gong et al. have formed a layered auxiliary graph for the node mapping. The link mapping is then solved with a shortest path routing approach. Wang et al. [298] have examined an embedding approach based on candidate mapping patterns that could provide the requested resources. The VON is then embedded according to a shortest path routing. Pages et al. [284] have considered embeddings that minimize the required optical transponders.

c) Survivable Embedding: Survivability of a virtual optical network, i.e., its continued operation in the face of physical node or link failures, is important for many applications that require dependable service. Hu et al. [299] developed an embedding that can survive the failure of a single physical node. Ye et al. [300] have examined the embedding of virtual optical networks so as to survive the failure of a single physical node or a physical link. Specifically, Ye et al. ensure that each virtual node request is mapped to a primary physical node as well as a distinct backup physical node. Similarly, each virtual link is mapped to a primary physical route as well as a node-disjoint backup physical route. Ye et al. mathematically formulate an optimization problem for the survivable embedding and then propose a Parallel Virtual Infrastructure (VI) Mapping (PAR) algorithm. The PAR algorithm finds distinct candidate physical nodes (with the highest remaining resources) for each virtual node request. The candidate physical nodes are then jointly examined with pairs of shortest node-disjoint paths. The evaluations in [300] indicate that the parallel PAR algorithm reduces the blocking probabilities of virtual network requests by 5–20 % compared to a sequential algorithm benchmark. A limitation of the survivable embedding [300] is that it

protects only from a single link or node failure. As the optical infrastructure is expected to penetrate deeper in the access network deployments (e.g., mobile backhaul), it will become necessary to consider multiple failure points. A similar survivable network embedding algorithm that employs node-disjoint shortest paths in conjunction with a specific cost metric for node mappings has been investigated by Xie et al. [301]. Jiang et al. [302] have examined a solution variant based on maximum-weight maximum clique formation.

Survivable virtual topology design in the context of multidomain optical networks has been studied by Hong et al. [303]. Hong et al. focused on minimizing the total network link cost for a given virtual traffic demand. A heuristic algorithm for partition and contraction mechanisms based on cut set theory has been proposed for the mapping of virtual links onto multidomain optical networks. A hierarchical SDN control plane is split between local controllers that to manage individual domains and a global controller for the overall management. The partition and contraction mechanisms abstract inter- and intra-domain information as a method of contraction. Survivability conditions are ensured individually for inter- and intra-domains such that survivability is met for the entire network. The evaluations in [303] demonstrate successful virtual network mapping at the scale required by commercial Internet service providers and infrastructure providers.

d) Dynamic Embedding: The embedding approaches surveyed so far have mainly focused on the offline embedding of a static set of virtual network requests. However, in the ongoing network operation the dynamic embedding of modifications (upgrades) of existing virtual networks, or the addition of new virtual networks are important. Ye et al. [304] have examined a variety of strategies for upgrading existing virtual topologies. Ye et al. have considered both scenarios without advance planning (knowledge) of virtual network upgrades and scenarios that plan ahead for possible (anticipated) upgrades. For both scenarios, a divide-and-conquer strategy and an integrate-and-cooperate strategy are examined. The divide-and-conquer strategy sequentially maps all the virtual nodes and then the virtual links. In contrast, the integrate-and-cooperate strategy jointly considers the virtual node and virtual link mappings. Without advance planning, these strategies are applied sequentially, as the virtual network requests arrive over time, whereas, with planning, the initial and upgrade requests are jointly considered. Evaluation results indicate that the integrate-and-cooperate strategy slightly increases a revenue measure and request acceptance ratio compared to the divide-and-conquer strategy. The results also indicate that planning has the potential to substantially increase the revenue and acceptance ratio. In a related study, Zhang et al. [305] have examined embedding algorithms for virtual network requests that arrive dynamically to a multilayer network consisting of electrical and optical network substrates.

e) Energy-efficient Embedding: Motivated by the growing importance of green networking and information technology [330], a few studies have begun to consider the energy efficiency of the embedded virtual optical networks. Nonde et al. [306] have developed and evaluated mechanisms for embedding virtual cloud networks so as to minimize the overall

power consumption, i.e., the aggregate of the power consumption for communication and computing (in the data centers). Nonde et al have incorporated the power consumption of the communication components, such as transponders and optical switches, as well as the power consumption characteristics of data center servers into a mathematical power minimization model. Nonde et al. then develop a real-time heuristic for energy-optimized virtual network embedding. The heuristic strives to consolidate computing requests in the physical nodes with the least residual computing capacity. This consolidation strategy is motivated by the typical power consumption characteristic of a compute server that has a significant idle power consumption and then grows linearly with increasing computing load; thus a fully loaded server is more energy-efficient than a lightly loaded server. The bandwidth demands are then routed between the nodes according to a minimum hop algorithm. The energy optimized embedding is compared with a cost optimized embedding that only seeks to minimize the number of utilized wavelength channels. The evaluation results in [306] indicate that the energy optimized embedding significantly reduces the overall energy consumption for low to moderate loads on the physical infrastructure; for high loads, when all physical resources need to be utilized, there are no significant savings. Across the entire load range, the energy optimized embedding saves on average 20 % energy compared to the benchmark minimizing the wavelength channels.

Chen [307] has examined a similar energy-efficient virtual optical network embedding that considers primary and link-disjoint backup paths, similar to the survivable embeddings in Section V-C1c. More specifically, virtual link requests are mapped in decreasing order of their bandwidth requirements to the shortest physical transmission distance paths, i.e., the highest virtual bandwidth demands are allocated to the shortest physical paths. Evaluations indicate that this link mapping approach roughly halves the power consumption compared to a random node mapping benchmark. Further studies focused on energy savings have examined virtual link embeddings that maximize the usage of nodes with renewable energy [308] and the traffic grooming [309] onto sliceable BVTs [331].

2) *Hypervisors for VONs*: The operation of VONs over a given underlying physical (substrate) optical network requires an intermediate hypervisor. The hypervisor presents the physical network as multiple isolated VONs to the corresponding VON controllers (with typically one VON controller per VON). In turn, the hypervisor intercepts the control messages issued by a VON controller and controls the physical network to effect the control actions desired by the VON controller for the corresponding VON.

Towards the development of an optical network hypervisor, Siquera et al. [310] have developed a SDN-based controller for an optical transport architecture. The controller implements a virtualized GMPLS control plane with offloading to facilitate the implementation of hypervisor functionalities, namely the creation optical virtual private networks, optical network slicing, and optical interface management. A major contribution of Siquera et al. [310] is an Transport Network Operating System (T-NOS), which abstracts the physical layer for the controller and could be utilized for hypervisor functionalities.

OpenSlice [311], a comprehensive OpenFlow-based hypervisor that creates VONs over underlying elastic optical networks [91], [92]. OpenSlice dynamically provisions end-to-end paths and offloads IP traffic by slicing the optical communications spectrum. The paths are set up through a handshake protocol that fills in cross-connection table entries. The control messages for slicing the optical communications spectrum, such as slot width and modulation format, are carried in extended OpenFlow protocol messages. OpenSlice relies on special distributed network elements, namely bandwidth variable wavelength cross-connects [332] and multiflow optical transponders [147] that have been extended for control through the extended OpenFlow messages. The OpenSlice evaluation includes an experimental demonstration. The evaluation results include path provisioning latency comparisons with a GMPLS-based control plane and indicate that OpenFlow outperforms GMPLS for paths with more than three hops. OpenSlice extension and refinements to multilayer and multidomain networks are surveyed in Section VII An alternate centralized Optical FlowVisor that does not require extensions to the distributed network elements has been investigated in [312].

D. Virtualization: Summary and Discussion

The virtualization studies on access networks [269]–[281] have primarily focused on exploiting and manipulating the specific properties of the optical physical layer (e.g., different OFDMA subcarriers) and MAC layer (e.g., polling based MAC protocol) of the optical access networks for virtualization. In addition, to virtualization studies on purely optical PON access networks, two sets of studies, namely sets [274]–[279] and WiMAX-VPON [280], [281] have examined virtualization for two forms of FiWi access networks. Future research needs to consider virtualization of a wider set of FiWi network technologies, i.e., FiWi networks that consider optical access networks with a wider variety of wireless access technologies, such as different forms of cellular access or combinations of cellular with other forms of wireless access. Also, virtualization of integrated access and metropolitan area networks [333]–[336] is an important future research direction.

A set of studies has begun to explore optical networking support for SDN-enabled cloudnets that exploit virtualization to dynamically pool resources across distributed data centers. One important direction for future work on cloudnets is to examine moving data center resources closer to the users and the subsequent resource pooling across edge networks [337]. Also, the exploration of the benefits of FiWi networks for decentralized cloudlets [338]–[341] that support mobile wireless network services is an important future research direction [342].

A fairly extensive set of studies has examined virtual network embedding for metro/core networks. The virtual network embedding studies have considered the specific limitations and constraints of optical networks and have begun to explore specialized embedding strategies that strive to meet a specific optimization objective, such as survivability, dynamic adaptability, or energy efficiency. Future research should seek to develop a comprehensive framework of embedding algorithms

Applications, Sec. VI

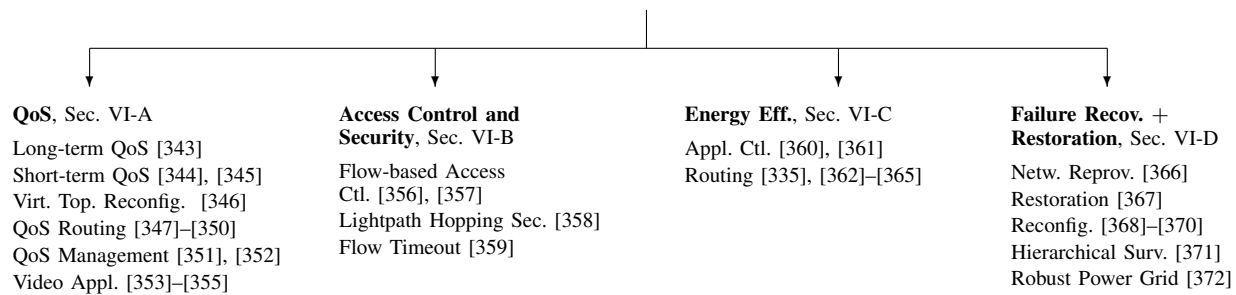

Fig. 12. Classification of application layer SDON studies.

that can be tuned with weights to achieve prescribed degrees of the different optimization objectives.

A relatively smaller set of studies has developed and refined hypervisors for creating VONs over metro/core optical networks. Much of the SDON hypervisor research has centered on the OpenSlice hypervisor concept [311]. While OpenSlice accounts for the specific characteristics of the optical transmission medium, it is relatively complex as it requires a distributed implementation with specialized optical networking components. Future research should seek to achieve the hypervisor functionalities with a wider set of common optical components so as to reduce cost and complexity. Overall, SDON hypervisor research should examine the performance-complexity/cost tradeoffs of distributed versus centralized approaches. Within this context of examining the spectrum of distributed to centralized hypervisors, future hypervisor research should further refine and optimize the virtualization mechanisms so as to achieve strict isolation between virtual network slices, as well as low-complexity hypervisor deployment, operation, and maintenance.

VI. SDN APPLICATION LAYER

In the SDN paradigm, applications interact with the controllers to implement network services. We organize the survey of the studies on application layer aspects of SDONs according to the main application categories of quality of service (QoS), access control and security, energy efficiency, and failure recovery, as illustrated in Fig. 12.

A. QoS

1) *Long-term QoS: Time-Aware SDN*: Data Center (DC) networks move data back and forth between DCs to balance the computing load and the data storage usage (for upload) [373]. These data movements between DCs can span large geographical areas and help ensure DC service QoS for the end users. Load balancing algorithms can exploit the characteristics of the user requests. One such request characteristic is the high degree of time-correlation over various time scales ranging from several hours of a day (e.g., due to a sporting event) to several days in a year (e.g., due to a political event). Zhao et al. [343] have proposed a time-aware SDN application using OpenFlow extensions to dynamically balance the load across the DC resources so as to improve the QoS. Specifically, a time correlated PCE algorithm based on flexi-grid optical transport (see Section IV-D2) has been proposed. An SDN

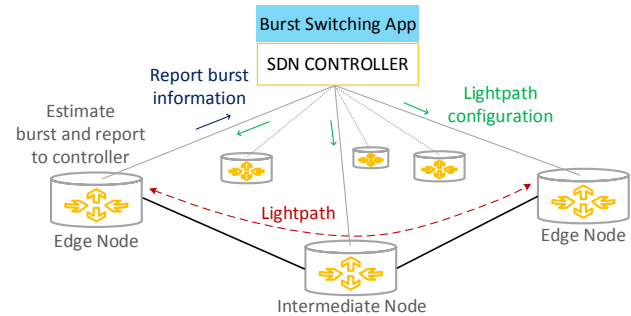

Fig. 13. Optical SDN-based QoS-aware burst switching application [345]: Based on short-term traffic burst estimates of an edge node, the SDN controller configures end-to-end light paths ensuring QoS.

application monitors the DC resources and applies network rules to preserve the QoS. Evaluations of the algorithm indicate improvements in terms of network blocking probability, global blocking probability, and spectrum consumption ratio. This study did not consider short time scale traffic bursts, which can significantly affect the load conditions. We believe that in order to avoid pitfalls in the operation of DC load balancing through PCE algorithms implemented with SDN, a wide range of traffic conditions needs to be considered. The considered traffic range should include short and long term traffic variations, which should be traded off with various QoS aspects, such as type of application and delay constraints, as well as the resulting costs and control overheads.

2) *Short Term QoS*: Users of a high-speed FTTH access network may request very large bandwidths due to simultaneously running applications that requiring high data rates. In such a scenario, applications requiring very high data rates may affect each other. For instance, a video conference running simultaneously with the streaming of a sports video may result in call drops in the video conference application and in stalls of the sports video. Li et al. [344] proposed an SDN based bandwidth provisioning application in the broadband remote access server [374] network. They defined and assigned the minimum bandwidth, which they named “sweet point”, required for each application to experience good QoE. Li et al. showed that maintaining the “sweet point” bandwidth for each application can significantly improve the QoE while other applications are being served according to their bandwidth requirements.

In a similar study, Patel et al. [345] proposed a burst switching mechanism based on a software defined optical network. Bursts typically originate at the edge nodes and

the aggregation points due to statistical multiplexing of high speed optical transmissions. To ensure QoS for multiple traffic classes, bursts at the edge nodes have to be managed by deciding their end-to-end path to meet their QoS requirements, such as minimum delay and data rate. In non-SDN based mechanisms, complicated distributed protocols, such as GMPLS [265], [267], are used to route the burst traffic. In the proposed application, the centralized unified control plane decides the routing path for the burst based on latency and QoS requirements. A simplified procedure involves (i) burst evaluation at the edge node, (ii) reporting burst information to the SDN controller, and (iii) sending of configurations to the optical nodes by the controller to set up a lightpath as illustrated in Fig. 13. Simulations indicate an increase of performance in terms of throughput, network blocking probability, and latency along with improved QoS when compared to non-SDN GMPLS methods.

3) *Virtual Topology Reconfigurations*: The QoS experienced by traffic flows greatly depends on their route through a network. Wette et al. [346] have examined an application algorithm that reconfigures WDM network virtual topologies (see Section V-C1b) according to the traffic levels. The algorithm considers the localized traffic information and optical resource availability at the nodes. The algorithm does not require synchronization, thus reducing the overhead while simplifying the network design. In the proposed architecture, optical switches are connected to ROADMs. The reconfiguration application manages and controls the optical switches through the SDN controller. A new WDM controller is introduced to configure the lightpaths taking wavelength conversion and lightpath switching at the ROADMs into consideration. The SDN controller operates on the optical network which appears as a static network, while the WDM controller configures (and re-configures) the ROADMs to create multiple virtual optical networks according to the traffic levels. Evaluation results indicate improved utilization and throughput. The results indicate that virtual topologies reconfigurations can significantly increase the flexibility of the network while achieving the desired QoS. However, the control overhead and the delay aspects due to virtualization and separation of control and lightwave paths needs to be carefully considered.

4) *End-to-End QoS Routing*: Interconnections between DCs involve typically multiple data paths. All the interfaces existing between DCs can be utilized by MultiPath TCP (MPTCP). Ensuring QoS in such an MPTCP setting while preserving throughput efficiency in a reconfigurable underlying burst switching optical network is a challenging task. Tariq et al. [347] have proposed QoS-aware bandwidth reservation for MPTCP in an SDON. The bandwidth reservation proceeds in two stages (i) path selection for MPTCP, and (ii) OBS wavelength reservation to assign the priorities for latency-sensitive flows. Larger portions of a wavelength reservation are assigned to high priority flows, resulting in reduced burst blocking probability while achieving the higher MPTCP throughput. The simulation results in [347] validate the two-stage algorithm for QoS-aware MPTCP over an SDON, indicating decreased dropping probabilities, and increased throughputs.

Information To the Routing System (I2RS) [375] is a high-

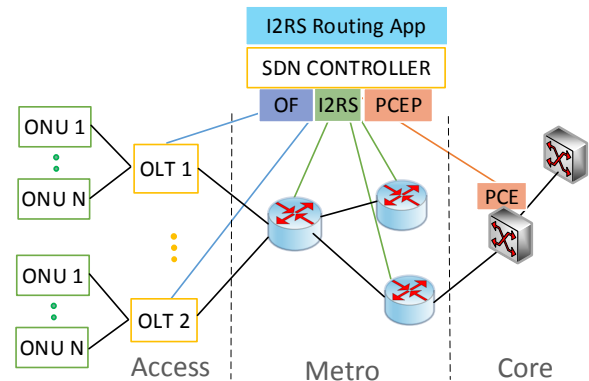

Fig. 14. Illustration of routing application with integrated control of access, metro, and core networks using SDN and the Information To the Routing System (I2RS) [348]: The SDN controller interacts with the access network, e.g., through the OpenFlow protocol, the metro network, e.g., through the I2RS, and the core network, e.g., through the Path Computation Elements (PCEs).

level architecture for communicating and interacting with routing systems, such as BGP routers. A routing system may consist of several complex functional entities, such as a Routing Information Base (RIB), a RIB manager, topology and policy databases, along with routing and signalling units. The I2RS provides a programmability platform that enables access and modifications of the configurations of the routing system elements. The I2RS can be extended with SDN principles to achieve global network management and reconfiguration [376]. Sgambelluri et al. [348] presented an SDN based routing application within the I2RS framework to integrate the control of the access, metro, and core networks as illustrated in Fig. 14. The SDN controller communicates with the Path Computation Elements (PCEs) of the core network to create Label Switched Paths (LSPs) based on the information received by the OLTs. Experimental demonstrations validated the routing optimization based on the current traffic status and previous load as well as the unified control interface for access, metro, and core networks.

Ilchmann et al. [349] developed an SDN application that communicates to an SDN controller via an HTTP-based REST API. Over time, lightpaths in an optical network can become inefficient for a number of reasons (e.g., optical spectrum fragmentation). For this reason, Ilchmann et al. developed an SDN application that evaluates existing lightpaths in an optical network and offers an application user the option to re-optimize the lightpath routing to improve various performance metrics (e.g., path length). The application is user-interactive in that the user can see the number of proposed lightpath routing changes before they are made and can potentially select a subset of the proposed changes to minimize network down-time.

At the ingress and egress routers of optical networks (e.g., the edge routers between access and metro networks), buffers are highly non-economical to implement, as they require large buffer sizes to accommodate the channel rates of 40 Mb/s or more. To reduce the buffer requirements at the edge routers, Chang et al. [350] have proposed a backpressure application referred to as Refill and SDN-based Random Early Detection (RS-RED). RS-RED implements a refill queue at the ingress

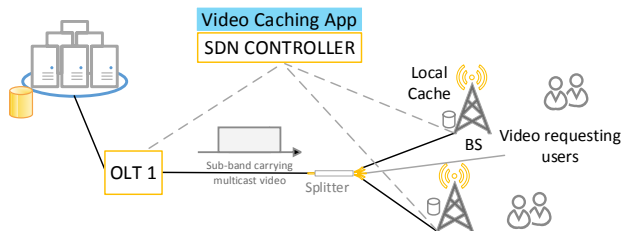

Fig. 15. SDN based video caching application in PON for mobile users [355]: The SDN controller pushes frequently requested videos to base station (BS) caches, whereby multicast can reach several BS caches.

device and a droptail queue at the egress device, whereby both queues are centrally managed by the RS-RED algorithm running on the SDN controller. Simulation results showed that at the expense of small delay increases, edge router buffer sizes can be significantly reduced.

5) *QoS Management*: Rukert et al. [351] proposed SDN based controlled home-gateway supporting heterogeneous wired technologies, such as DSL, and wireless technologies, such as LTE and WiFi. SDN controllers managed by the ISPs optimize the traffic flows to each user while accommodating large numbers of users and ensuring their minimum QoS. Additionally, Tego et al. [352] demonstrated an experimental SDN based QoS management setup to optimize the energy utilization. GbE links are switched on and off based on the traffic levels. The QoS management reroutes the traffic to avoid congestion and achieve efficient throughput. SDN applications conduct active QoS probing to monitor the network QoS characteristics. Evaluations have indicated that the SDN based techniques achieve significantly higher throughput than non-SDN techniques [352].

6) *Video Applications*: The application-aware SDN-enabled resource allocation application has been introduced by Chitimalla et al. [353] to improve the video QoE in a PON access network. The resource allocation application uses application level feedback to schedule the optical resources. The video resolution is incrementally increased or decreased based on the buffer utilization statistics that the client sends to the controller. The scheduler at the OLT schedules the packets based on weights calculated by the SDN controller, whereby the video applications at the clients communicate with the controller to determine the weights. If the network is congested, then the SDN controller communicates to the clients to reduce the video resolution so as to reduce the stalls and to improve the QoE.

Caching of video data close the users is generally beneficial for improving the QoE of video services [377], [378]. Li et al. [355] have introduced caching mechanisms for software-defined PONs. In particular, Li et al. have proposed joint provisioning of the bandwidth to service the video and the cache management, as illustrated in Fig. 16. Based on the request frequency for specific video content, the Base Station (BS) caches the content with the assistance of the SDN controller. The proposed *push*-based mechanism delivers (pushes) the video to the BS caches when the PON is not congested. A specific PON transmission sub-band can be used to multicast video content that needs to be cached at multiple BSs. The simulation evaluation in [355] indicate that up to 30% addi-

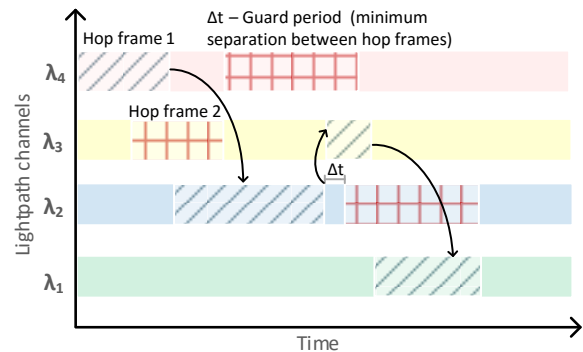

Fig. 16. Overview of optical light path hopping mechanism to secure link from eavesdropping and jamming [358]: The flow marked by the diagonal shading hops from lightpath channel λ_4 to λ_2 , then to λ_3 and on to λ_1 . Transmissions by distinct flows on a given lightpath channel must be separated by at least a guard period.

tional videos can be serviced while the service response delay is reduced to 50%.

B. Access Control and Security

1) *Flow-based Access Control*: Network Access Control (NAC) is a networking application that regulates the access to network services [242], [379]. A NAC based on traffic flows has been developed by Matias [356]. Flow-NAC exploits the forwarding rules of OpenFlow switches, which are set by a central SDN controller, to control the access of traffic flows to network services. FlowNAC can implement the access control based on various flow identifiers, such as MAC addresses or IP source and destination addresses. Performance evaluations measured the connections times for flows on a testbed and found average connection times on the order of 100 ms for completing the flow access control.

In a related study, Nayak et al. [357] developed the Resonance flow based access control system for an enterprise network. In the Resonance system, the network elements, such as the routers themselves, dynamically enforce access control policies. The access control policies are implemented through real-time alerts and flow based information that is exchanged with SDN principles. Nayak et al. have demonstrated the Resonance system on a production network at Georgia Tech. The Resonance design can be readily implemented in SDON networks and can be readily extended to wide area networks. Consider for example multiple heterogeneous DCs of multiple organizations that are connected by an optical backbone network. The Resonance system can be extended to provide access control mechanisms, such as authentication and authorization, through such a wide area SDON.

2) *Lightpath Hopping Security*: The broad network perspective of SDN controllers facilitates the implementation of security functions that require this broad perspective [27], [28], [380]. However, SDN may also be vulnerable to a wide range of attacks and vulnerabilities, including unauthorized access, data leakage, data modification, and misconfiguration. Eavesdropping and jamming are security threats on the physical layer and are especially relevant for the optical layer of SDONs. In order to prevent eavesdropping and jamming in an optical lightpath, Li et al. [358] have proposed an

SDN based fast lightpath hopping mechanism. As illustrated in Fig. 16, the hopping mechanism operates over multiple lightpath channels. Conventional optical lightpath setup times range from several hundreds of milliseconds to several seconds and would result in a very low hopping frequency. To avoid the optical setup times during each hopping period, an SDN based high precision time synchronization has been proposed. As a result, a fast hopping mechanism can be implemented and executed in a coordinated manner. A hop frame is defined and guard periods are added in between hop frames. The experimental evaluations indicate that a maximum hopping frequency of 1 MHz can be achieved with a BER of 1×10^{-3} . However, shortcomings of such mechanisms are the secure exchange of hopping sequences between the transmitter and the receiver. Although, centralized SDN control provides authenticated provisioning of the hopping sequence, additional mechanisms to secure the hopping sequence from being obtained through man-in-the-middle attacks should be investigated.

3) *Flow Timeout*: SDN flow actions on the forwarding and switching elements have generally a validity period. Upon expiration of the validity period, i.e., the flow action timeout, the forwarding or switching element drops the flow action from the forwarding information base or the flow table. The switching element CPU must be able to access the flow action information with very low latency so as to perform switching actions at the line rate. Therefore, the flow actions are commonly stored in Ternary Content Addressable Memories (TCAMs) [381], which are limited to storing on the order of thousands of distinct entries. In SDONs, the optical network elements perform the actions set by the SDN controller. These actions have to be stored in a finite memory space. Therefore, it is important to utilize the finite memory space as efficiently as possible [382]–[386]. In the dynamic timeout approach [359], the SDN controller tracks the TCAM occupancy levels in the switches and adjusts timeout durations accordingly. However, a shortcoming of such techniques is that the bookkeeping processes at the SDN controllers can become cumbersome for a large network. Therefore, autonomous timeout management techniques that are implemented at the hypervisors can reduce the controller processing load and are an important future research direction.

C. Energy Efficiency

The separation of the control plane from the data plane and the global network perspective are unique advantages of SDN for improving the energy efficiency of networks, which is an important goal [387], [388].

1) *Power-saving Application Controller*: Ji et al. [360] have proposed an all optical energy-efficient network centered around an application controller [361] that monitors power consumption characteristics and enforces power savings policies. Ji et al. first introduce energy-efficient variations of Digital-to-Analog Converters (DACs) and wavelength selective ROADMs as components for their energy-efficient network. Second, Jie et al. introduce an energy-efficient switch architecture that consists of multiple parallel switching planes,

whereby each plane consists of three stages with optical burst switching employed in the second (central) switching stage. Third, Jie et al. detail a multilevel SDN based control architecture for the network built from the introduced components and switch. The control structure accommodates multiple networks domains, whereby each network domain can involve multiple switching technologies, such as time-based and frequency-based optical switching. All controllers for the various domains and technologies are placed under the control of an application controller. Dedicated power monitors that are distributed throughout the network update the SDN based application controller about the energy consumption characteristics of each network node. Based on the received energy consumption updates, the application controller executes power-saving strategies. The resulting control actions are signalled by the application controller to the various controllers for the different network domains and technologies.

2) *Energy-Saving Routing*: Tego et al. [362] have proposed an energy-saving application that switches off under-utilized GbE network links. Specifically, Tego et al. proposed two methods: Fixed Upper Fixed Lower (FUFL) and Dynamic Upper and Fixed Lower (DLFU). In FUFL, the IP routing and the connectivity of the logical topology are *fixed*. The utilization of physical GbE links (whereby multiple parallel physical links form a logical link) is compared with a threshold to determine whether to switch off or on individual physical links (that support a given logical link). The traffic on a physical link that is about to be switched off is rerouted on a parallel physical GbE link (within the same logical link). In contrast, in the DLFU approach, the energy saving application monitors the load levels on the virtual links. If the load level on a given virtual link falls below a threshold value, then the virtual link topology is reconfigured to eliminate the virtual link with the low load. A general pitfall of such link switch-off techniques is that energy savings may be achieved at the expense of deteriorating QoS. The QoS should therefore be closely monitored when switching off links and re-routing flows.

A similar SDN based routing strategy that strives to save energy while preserving the QoS has been examined in the context of a GMPLS optical networks in [363]. Multipath routing optimizing applications that strive to save energy in an SDN based transport optical network have been presented in [364]. A similar SDN based optimization approach for reducing the energy consumption in data centers has been examined by Yoon et al. [365]. Yoon et al. formulated a mixed integer linear program that models the switches and hosts as queues. Essentially, the optimization decides on the switches and hosts that could be turned off. As the problem is NP-hard, annealing algorithms are examined. Simulations indicate that energy savings of more than 80% are possible for low data center utilization rates, while the energy savings decrease to less than 40% for high data center utilization rates. Traffic balancing in the metro optical access networks through the SDN based reconfiguration of optical subscriber units in a TWDM-PON systems for energy savings has been additionally demonstrated in [335].

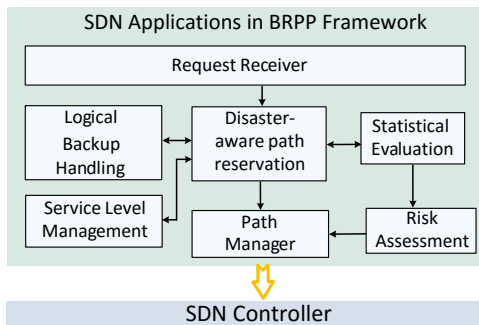

Fig. 17. Illustration of application layer modules of SDN based network reprovisioning framework for disaster aware networking [366].

D. Failure Recovery and Restoration

1) *Network Reprovisioning*: Network disruptions can occur due to various natural and/or man-made factors. Network resource reprovisioning is a process to change the network configurations, e.g., the network topology and routes, to recover from failures. A Backup Reprovisioning with Path Protection (BRPP), based on SDN for optical networks has been presented by Savas et al. [366]. An SDN application framework as illustrated in Fig. 17 was designed to support the reprovisioning with services, such as provisioning the new connections, risk assessment, as well as service level and backup management. When new requests are received by the BRPP application framework, the statistics module evaluates the network state to find the primary path and a link-disjoint backup path. The computed backup paths are stored as logical links without being provisioned on the physical network. The logical backup module manages and recalculates the logical links when a new backup path cannot be accommodated or to optimize the existing backup paths (e.g., minimize the backup path distance). Savas et al. introduce a degraded backup path mechanism that reserves not the full, but a lower (degraded) transmission capacity on the backup paths, so as to accommodate more requests. Emulations of the proposed mechanisms indicate improved network utilization while effectively provisioning the backup paths for restoring the network after network failures.

As a part of DARPA's core optical networks CORONET project, a non-SDN based Robust Optical Layer End-to-end X-connection (ROLEX) protocol has been demonstrated and presented along with the lessons learned [389]. ROLEX is a distributed protocol for failure recovery which requires a considerable amount of signaling between nodes for the distributed management. Therefore to avoid the pitfall of excessive signalling, it may be worthwhile to examine a ROLEX version with centralized SDN control in future research to reduce the recovery time and signaling overhead, as well as the costs of restored paths while ensuring the user QoS.

2) *Restoration Processing*: During a restoration, the network control plane simultaneously triggers backup provisioning of all disrupted paths. In GMPLS restoration, along with signal flooding, there can be contention of signal messages at the network nodes. Contentions may arise due to spectrum conflicts of the lightpath, or node-configuration overrides, i.e., a new configuration request arrives while a preceding recon-

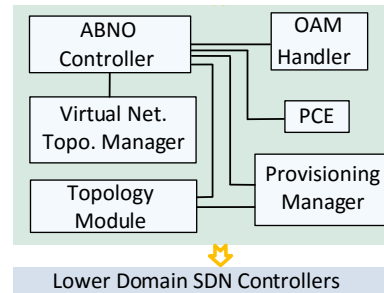

Fig. 18. Illustration of Application-Based Network Operation (ABNO) architecture: The ABNO controller communicates with the Operation, Administration, and Maintenance (OAM) module, the Path Computation Element (PCE) module as well as the topology modules and the provisioning manager to control the lower domain SDN controllers so as to recover from network failures [368].

figuration is under way. Giorgetti et al. [367] have proposed dynamic restoration in the elastic optical network to avoid signaling contention in SDN (i.e., of OpenFlow messages). Two SDN restoration mechanisms were presented: (i) the independent restoration scheme (SDN-ind), and (ii) the bundle restoration scheme (SDN-bund). In SDN-ind, the controller triggers simultaneous independent flow modification (Flow-Mod) messages for each backup path to the switches involved in the reconfigurations. During contention, switches enqueue the multiple received Flow-Mod messages and process them sequentially. Although SDN-ind achieves reduced recovery time as compared to non-SDN GMPLS, the waiting of messages in the queue incurs a delay. In SDN-bund, the backup path reconfigurations are bundled into a single message, i.e., a Bundle Flow-Mod message, and sent to each involved switch. Each switch then configures the flow modifications in one re-configuration, eliminating the delay incurred by the queuing of Flow-Mod messages. A similar OpenFlow enabled restoration in Elastic Optical Networks (EONs) has been studied in [390].

3) *Reconfiguration*: Aguado et al. [368] have demonstrated a failure recovery mechanism as part of the EU FP7 STRAUSS project with dynamic virtual reconfigurations using SDN. They considered multidomain hypervisors and domain-specific controllers to virtualize the multidomain networks. The Application-Based Network Operations (ABNO) framework illustrated in Fig. 18 enables network automation and programmability. ABNO can compute end-to-end optical paths and delegate the configurations to lower layer domain SDN controllers. Requirements for fast recovery from network failures would be in the order of tens of milliseconds, which is challenging to achieve in large scale networks. ABNO reduces the recovery times by pre-computing the backup connections after the first failure, while the Operation, Administration and Maintenance (OAM) module [391] communicates with the ABNO controller to configure the new end-to-end connections in response to a failure alarm. Failure alarms are triggered by the domain SDN controllers monitoring the traffic via the optical power meters when power is below -20 dBm.

A similar design for end-to-end protection and failure recovery has been demonstrated by Slyne et al. [369] for a long-reach (LR) PON. LR-PON failures are highly likely due to physical breaks in the long feeder fibers. Along with the high impact of connectivity break down or degraded service,

physical restoration time can be very long. Therefore, 1:1 protection for LR-PONs based on SDN has been proposed, where primary and secondary (backup) OLTs are used without traffic duplication. More specifically, Slyne et al. have devised and demonstrated an OpenFlow-Relay located at the switching unit. The OpenFlow-Relay detects and reports a failure along with fast updating of forwarding rules. Experimental demonstration show the backup OLT carrying protected traffic within 7.2 ms after a failure event.

An experimental demonstration utilizing multiple paths in optical transport networks for failure recovery has been discussed by Kim et al. [370]. Kim et al. have used commercial grade IP WDM network equipment and implemented multipath TCP in an SDN framework to emulate inter-DC communication. They developed an SDN application, consisting of an cross-layer service manager module and a cross-layer multipath transport module to reconfigure the optical paths for the recovery from connection impairments. Their evaluations show increased bandwidth utilization and reduced cost while being resilient to network impairments as the cross-layer multipath transport module does not reserve the backup path on the transport network.

4) *Hierarchical Survivability*: Networks can be made survivable by introducing resource redundancy. However, the cost of the network increases with increased redundancy. Zhang et al. [371] have demonstrated a highly survivable IP-Optical multilayered transport network. Hierarchical controllers are placed for multilayer resource provisioning. Optical nodes are controlled by Transport Controllers (TCs), while higher layers (IP) are controlled by unified controllers (UCs). The UCs communicate with the TCs to optimize the routes based on cross-layer information. If a fiber causes a service disruption, TCs may directly set up alternate routes or ask the UCs for optimized routes. A pitfall of such hierarchical control techniques can be long restoration times. However, the cross layer restorations can recover from high degrees of failures, such as multipoint and concurrent failures.

5) *Robust Power Grid*: The lack of a reliable communication infrastructure for power grid management was one of the many reasons for the widespread blackout in the Northeastern U.S.A. in the year 2003, which affected the lives of 50 million people [392]. Since then building a reliable communication infrastructure for the power grid has become an important priority. Rastegarfar et al. [372] have proposed a communication infrastructure that is focused on monitoring and can react to and recover from failures so as to reliably support power grid applications. More specifically, their architecture was built on SDN based optical networking for implementing robust power grid control applications. Control and infrastructure in the SDN based power grid management exhibits an interdependency i.e., the physical fiber relies on the control plane for its operations and the logical control plane relies on the same physical fiber for its signalling communications. Therefore, they only focus on optical protection switching instead of IP layer protection, for the resilience of the SDN control. Cascaded failure mechanisms were modeled and simulated for two geographical topologies (U.S. and E.U.). In addition, the impacts of cascaded failures were studied for two scenarios

(i) static optical layer (static OL), and (ii) dynamic optical layer (dynamic OL). Results for a static OL illustrated that the failure cascades are persistent and are closely dependent on the network topology. However, for a dynamic OL (i.e., with reconfiguration of the physical layer), failure cascades were suppressed by an average of 73%.

E. Application Layer: Summary and Discussion

The SDON QoS application studies have mainly examined traffic and network management mechanisms that are supported through the OpenFlow protocol and the central SDN controller. The studied SDON QoS applications are structurally very similar in that the traffic conditions or network states (e.g., congestion levels) are probed or monitored by the central SDN controller. The centralized knowledge of the traffic and network is then utilized to allocate or configure resources, such as DC resources in [343], application bandwidths in [344], and topology configurations or routes in [346]–[348], [350]. Future research on SDON QoS needs to further optimize the interactions of the controller with the network applications and data plane to quickly and correctly react to changing user demands and network conditions, so as to assure consistent QoS. The specific characteristics and requirements of video streaming applications have been considered in the few studies on video QoS [353]–[355]. Future SDON QoS research should consider a wider range of specific prominent application traffic types with specific characteristics and requirements, e.g., Voice over IP (VoIP) traffic has relatively low bit rate requirements, but requires low end-to-end latency.

Very few studies have considered security and access control for SDONs. The thorough study of the broad topic area of security and privacy is an important future research direction in SDONs, as outlined in Section VIII-C Energy efficiency is similarly a highly important topic within the SDON research area that has received relatively little attention so far and presents overarching research challenges, see Section VIII-I.

One common theme of the SDON application layer studies focused on failure recovery and restoration has been to exploit the global perspective of the SDN control. The global perspective has been exploited for improved planning of the recovery and restoration [366], [368], [371] as well as for improved coordination of the execution of the restoration processes [367], [390]. Generally, the existing failure recovery and restoration studies have focused on network (routing) domain that is owned by a particular organizational entity. Future research should seek to examine the tradeoffs when exploiting the global perspective of orchestration of multiple routing domains, i.e., the failure recovery and restoration techniques surveyed in this section could be combined with the multidomain orchestration techniques surveyed in Section VII. One concrete example of multidomain orchestration could be to coordinate the specific LR-PON access network protection and failure recovery [369] with protection and recovery techniques for metropolitan and core network domains, e.g., [366], [368], [370], [371], for improved end-to-end protection and recovery.

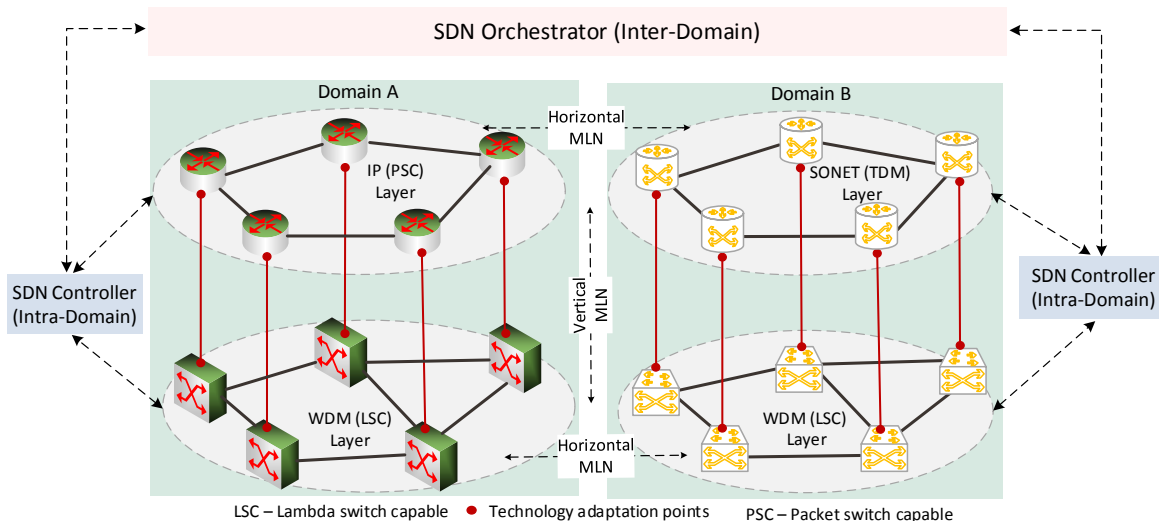

Fig. 19. Illustration of SDN orchestration of multilayer networking: Vertical MultiLayer Networking (MLN) spans layers at different horizontal positions within a given domain. Horizontal MLN spans multiple layers at the same horizontal position (or in different horizontal positions) across multiple domains. The inter-domain SDN orchestrator coordinates the individual intra-domain SDN controllers.

VII. ORCHESTRATION

As introduced in Section II-A4, orchestration accomplishes higher layer abstract coordination of network services and operations. In the context of SDNs, orchestration has mainly been studied in support of multilayer networking. Multilayer networking in the context of SDN and network virtualization generally refers to networking across multiple network layers and their respective technologies, such as IP, MPLS, and WDM, in combination with networking across multiple routing domains [75], [393]–[396]. The concept of multilayer networking is generally an abstraction of providing network services with multiple networking layers (technologies) and multiple routing domains. The different network layers and their technologies are sometimes classified into Layer 0 (e.g., fiber-switch capable), Layer 1 (e.g., lambda switching capable), Layer 1.5 (e.g., TDM SONET/SDH), Layer 2 (e.g., Ethernet), Layer 2.5 (e.g., packet switching capable using MPLS), and Layer 3 (e.g., packet switching capable using IP routing) [397]. Routing domains are also commonly referred to as network domains, routing areas, or levels [393].

The recent multilayer networking review article [393] has introduced a range of capability planes to represent the grouping of related functionalities for a given networking technology. The capability planes include the data plane for transmitting and switching data. The control plane and the management plane directly interact with the data plane for controlling and provisioning data plane services as well as for trouble shooting and monitoring the data plane. Furthermore, an authentication and authorization plane, a service plane, and an application plane have been introduced for providing network services to users.

Multilayer networking can involve vertical layering or horizontal layering [393], as illustrated in Fig. 19. In vertical layering, a given layer, e.g., the routing layer, which may employ a particular technology, e.g., the Internet Protocol (IP), uses another (underlying) layer, e.g., the Wavelength Division Multiplexing (WDM) circuit switching layer, to provide services to higher layers. In horizontal layering, services are

provided by “stitching” together a service path across multiple routing domains.

SDN provides a convenient control framework for these flexible multilayer networks [393]. Several research networks, such as ESnet, Internet2, GEANT, Science DMZ (Demilitarized Zone) have experimented with these multilayer networking concepts [398], [399]. In particular, SDN based multilayer network architectures, e.g., [336], [400], [401], are formed by conjoining the layered technology regions (*i*) in vertical fashion i.e., multiple technology layers internetwork within a single domain, or (*ii*) in horizontal layering fashion across multiple domains, i.e., technology layers internetwork across distinct domains. Horizontal multilayer networking can be viewed as a generalization of vertical multilayer networking in that the horizontal networking may involve the same or different (or even multiple) layers in the distinct domains. As illustrated in Figure 19, the formed SDN based multilayer network architecture is controlled by an SDN orchestrator. As illustrated in Fig. 20 we organize the SDN orchestration studies according to their focus into studies that primarily address the orchestration of vertical multilayer (multitechnology) networking, i.e., the vertical networking across multiple layers (that typically implement different technologies) within a given domain, and into studies that primarily address the orchestration of horizontal multilayer (multidomain) networking, i.e., the horizontal networking across multiple routing domains (which may possibly involve different or multiple vertical layers in the different domains). We subclassify the vertical multilayer studies into general (vertical) multilayer networking frameworks and studies focused on supporting specific applications through vertical multilayer networking. We subclassify the multidomain (horizontal multilayer) networking studies into studies on general network domains and studies focused on internetworking with Data Center (DC) network domains.

A. Multilayer Orchestration

1) Multilayer Orchestration Frameworks:

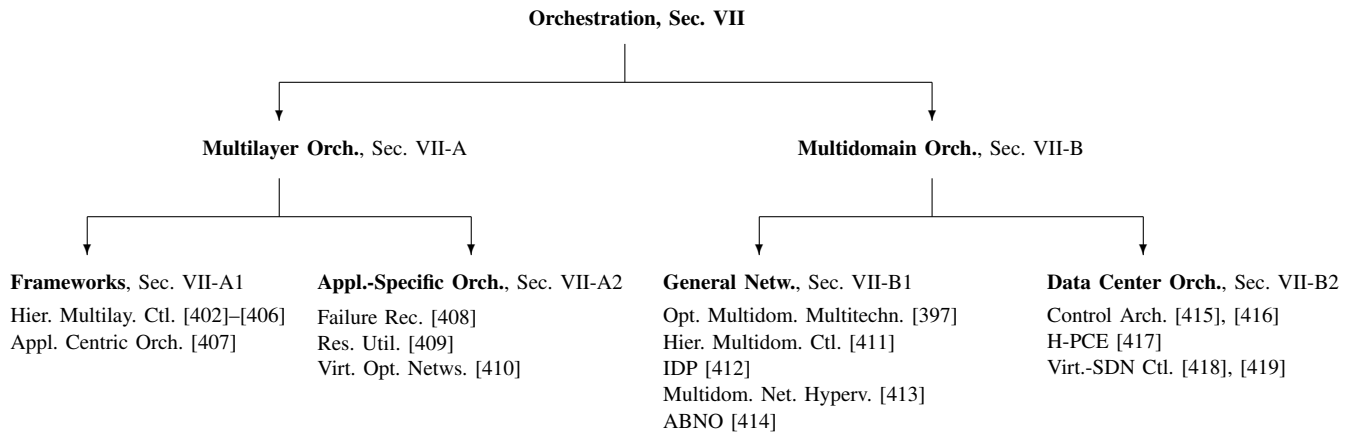

Fig. 20. Classification of SDN orchestration studies: Multilayer orchestration studies focus on vertical multilayer networking within a single domain. Multidomain orchestration studies focus on horizontal multilayer networking across multiple domains and may involve multiple vertical layers in the various domains.

a) Hierarchical Multilayer Control: Felix et al. [402] presented an hierarchical SDN control mechanism for packet optical networks. Multilayer optimization techniques are employed at the SDN orchestrator to integrate the optical transport technology with packet services by provisioning end-to-end Ethernet services. Two aspects are investigated, namely (i) bandwidth optimization for the optical transport services, and (ii) congestion control for packet network services in an integrated packet optical network. More specifically, the SDN controller initially allocates the minimum available bandwidth required for the services and then dynamically scales allocations based on the availability. Optical-Virtual Private Networks (O-VPNs) are created over the physical transport network. Services are then mapped to O-VPNs based on class of service requirements. When congestion is detected for a service, the SDN controller switches the service to another O-VPN, thus balancing the traffic to maintain the required class of service.

Similar steps towards the orchestration of multilayer networks have been taken within the OFELIA project [403]–[405]. Specifically, Shirazipour et al. [406] have explored extensions to OpenFlow version 1.1 actions to enable multitechnology transport layers, including Ethernet transport and optical transport. The explorations of the extensions include justifications of the use of SDN in circuit-based transport networks.

b) Application Centric Orchestration: Gerstel et al. [407] proposed an application centric network service provisioning approach based on multilayer orchestration. This approach enables the network applications to directly interact with the physical layer resource allocations to achieve the desired service requirements. Application requirements for a network service may include maximum end-to-end latency, connection setup and hold times, failure protection, as well as security and encryption. In traditional IP networking, packets from multiple applications requiring heterogeneous services are simply aggregated and sent over a common transport link (IP services). As a result, network applications are typically assigned to a single (common) transport service within an optical link. Consider a failure recovery process with multiple available paths. IP networking typically selects the single path

with the least end-to-end delay. However, some applications may tolerate higher latencies and therefore, the traffic can be split over multiple restoration paths achieving better traffic management. The orchestrator needs to interact with multiple network controllers operating across multiple (vertical) layers supported by north/south bound interfaces to achieve the application centric control. Dynamic additions of new IP links are demonstrated to accommodate the requirements of multiple application services with multiple IP links when the load on the existing IP link was increased.

2) Application-specific Orchestration:

a) Failure Recovery: Generally, network CapEx and OpEx increase as more protection against network failures is added. Khaddam et al. [408] propose an SDN based integration of multiple layers, such as WDM and IP, in a failure recovery mechanism to improve the utilization (i.e., to eventually reduce CapEx and OpEx while maintaining high protection levels). An observation study was conducted over a five year period to understand the impact of network failures on the real deployment of backbone networks. Results showed 75 distinct failures following a Pareto distribution, in which, 48% of the total deployed capacity was affected by the top (i.e., the highest impact) 20% of the failures. And, 10% of the total deployed capacity was impacted by the top two failure instances. These results emphasize the significance of backup capacities in the optical links for restoration processes. However, attaining the optimal protection capacities while achieving a high utilization of the optical links is challenging. A failure recovery mechanism is proposed based on a “hybrid” (i.e., combination of optical transport and IP) multilayer optimization. The hybrid mechanism improved the optical link utilization up to 50%. Specifically, 30% increase of the transport capacity utilization is achieved by dynamically reusing the remainder capacities in the optical links, i.e., the capacity reserved for failure recoveries. The multilayer optimization technique was validated on an experimental testbed utilizing central path-computation (PCE) [68] within the SDN framework. Experimental verification of failure recovery mechanism resulted in recovery times on the order of sub-seconds for MPLS restorations and several seconds for optical WSON restorations.

b) *Resource Utilization*: Liu et al. [409] proposed a method to improve resource utilization and to reduce transmission latencies through the processes of virtualization and service abstraction. A centralized SDN control implements the service abstraction layer (to enable SDN orchestrations) in order to integrate the network topology management (across both IP and WDM), and the spectrum resource allocation in a single control platform. The SDN orchestrator also achieves dynamic and simultaneous connection establishment across both IP and OTN layers reducing the transmission latencies. The control plane design is split between local (child) and root (parent) controllers. The local controller realizes the label switched paths on the optical nodes while the root controller realizes the forwarding rules for realizing the IP layer. Experimental evaluation of average transfer time measurements showed IP layer latencies on the order of several milliseconds, and several hundreds of milliseconds for the OTN latencies, validating the feasibility of control plane unification for IP over optical transport networks.

c) *Virtual Optical Networks (VONs)*: Vilalta et al. [410] presented controller orchestration to integrate multiple transport network technologies, such as IP and GMPLS. The proposed architectural framework devises VONs to enable the virtualization of the physical resources within each domain. VONs are managed by lower level physical controllers (PCs), which are hierarchically managed by an SDN network orchestrator (NO). Network Virtualization Controllers (NVC) are introduced (on top of the NO) to abstract the virtualized multilayers across multiple domains. End-to-end provisioning of VONs is facilitated through hierarchical control interaction over three levels, the customer controller, the NO&NVCs, and the PCs. An experimental evaluation demonstrated average VON provisioning delays on the order of several seconds (5 s and 10 s), validating the flexibility of dynamic VON deployments over the optical transport networks. Longer provisioning delays may impact the network application requirements, such as failure recovery processes, congestion control, and traffic engineering. General pitfalls of such hierarchical structures are increased control plane complexity, risk of controller failures, and maintenance of reliable communication links between control plane entities.

B. Multidomain Orchestration

Large scale network deployments typically involve multiple domains, which have often heterogeneous layer technologies. Achieve high utilization of the networking resources while provisioning end-to-end network paths and services across multiple domains and their respective layers and respective technologies is highly challenging [420]–[422]. Multidomain SDN orchestration studies have sought to exploit the unified SDN control plane to aid the resource-efficient provisioning across the multiple domains.

1) General Multidomain Networks:

a) Optical Multitechnologies Across Multiple Domains:

Optical nodes are becoming increasingly reconfigurable (e.g., through variable BVTs and OFDM transceivers, see Section III), adding flexibility to the switching elements. When

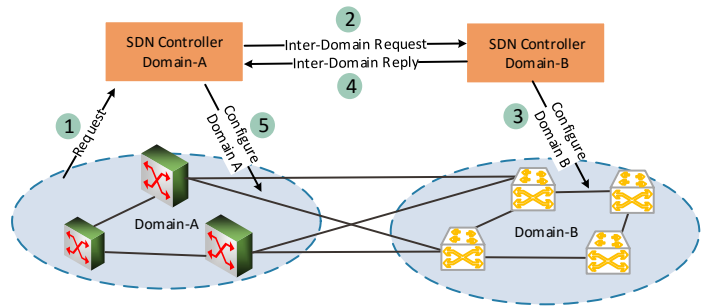

Fig. 21. Inter-domain lightpath provisioning mechanism facilitated by an Inter-Domain Protocol (IDP, which provides inter-domain request and inter-domain reply messages) by employing the Routing and Spectrum Allocation (RSA) algorithm proposed in [412]. Steps 1 through 5 provision an end-to-end path across multiple domains.

a single end-to-end service establishment is considered, it is more likely that a service is supported by different optical technologies that operate across multiple domains. Yoshida et al. [397] have demonstrated SDN based orchestration with emphasis on the physical interconnects between multiple domains and multiple technology specific controllers so as to realize end-to-end services. OpenFlow capabilities have been extended for fixed-length variable capacity optical packet switching [423]. That is, when an optical switch matches the label on an incoming optical packet, if a rule exists in the switch (flow entry in the table) for a specific label, a defined action is performed on the optical packet by the switch. Otherwise, the optical packet is dropped and the controller is notified. Interconnects between optical packet switching networks and elastic optical networks are enabled through a novel OPS-EON interface card. The OPS-EON interface is designed as an extension to a reconfigurable, programmable and flexi-grid EON supporting the OpenFlow protocol. The testbed implementation of OPS-EON interface cards demonstrated the orchestration of multiple domain controllers and the reconfigurability of FL-VC OPS across multidomain, multilayer, multitechnology scenarios.

b) *Hierarchical Multidomain Control*: Jing et al. [411] have also examined the integration of multiple optical transport technologies from to multiple vendors across multiple domains, focusing on the control mechanisms across multiple domains. Jing et al. proposed hierarchical SDN orchestration with parent and domain controllers. Domain controllers abstract the physical layer by virtualizing the network resources. A Parent Controller (PC) encompasses a Connection Controller (CC) and a Routing Controller (RC) to process the abstracted virtual network. When a new connection setup request is received by the PC, the RC (within the PC) evaluates the end-to-end routing mechanisms and forwards the information to the CC. The CC breaks the end-to-end routing information into shorter link segments belonging to a domain. Segmented routes are then sent to the respective domain controllers for link provisioning over the physical infrastructures. The proposed mechanism was experimentally verified on a testbed built with the commercial OTN equipment.

c) *Inter-Domain Protocol*: Zhu et al. [412] followed a different approach for the SDN multidomain control mech-

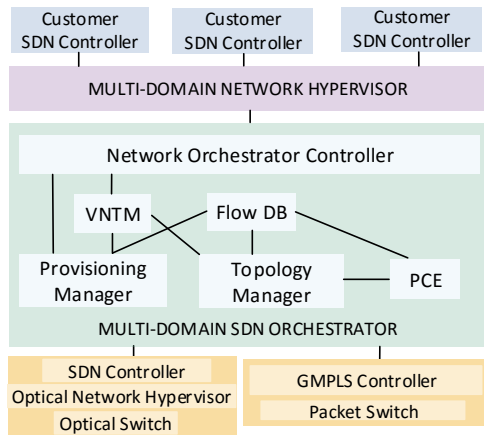

Fig. 22. Illustration of multilevel virtualization enabled by the Multidomain Network Hypervisor (MNH) [413] operating over a network orchestrator controller and domain specific SDN controllers to provide the multidomain end-to-end virtualization.

anisms by considering the flat arrangement of controllers as shown in Fig. 21. Each domain is autonomously managed by an SDN controller specific to the domain. An Inter-Domain Protocol (IDP) was devised to establish the communication between domain specific controllers to coordinate the lightpath setup across multiple domains. Zhu et al. also proposed a Routing and Spectrum Allocation (RSA) algorithm for the end-to-end provisioning of services in the SD-EONs. The distributed RSA algorithm operates on the domain specific controllers using the IDP protocol. The RSA considers both transparent lightpath connections, i.e., all-optical lightpath, and translucent lightpath connections, i.e., optical-electrical-optical connections. The benefit of such techniques is privacy, since the domain specific policies and topology information are not shared among other network entities. Neighbor discovery is independently conducted by the domain specific controller or can initially be configured. A domain appears as an abstracted virtual node to all other domain specific controllers. Each controller then assigns the shortest path routing within a domain between its border nodes. An experimental setup validating the proposed mechanism was demonstrated across geographically-distributed domains in the USA and China.

d) Multidomain Network Hypervisors: Vilalta et al. [413] presented a mechanism for virtualizing multitechnology optical, multitenant networks. The Multidomain Network Hypervisor (MNH) creates customer specific virtual network slices managed by the customer specific SDN controllers (residing at the customers' locations) as illustrated in Fig. 22. Physical resources are managed by their domain specific physical SDN controllers. The MNH operates over the network orchestrator and physical SDN controllers for provisioning VONs on the physical infrastructures. The MNHs abstracts both (i) multiple optical transport technologies, such as optical packet switching and Elastic Optical Networks (EONs), and (ii) multiple control domains, such as GMPLS and OpenFlow. Experimental assessments on a testbed achieved VON provisioning within a few seconds (5 s), and control overhead delay on the order of several tens of milliseconds. Related virtualization mechanisms for multidomain optical SDN networks with end-to-end provisioning have been investigated in [424], [425].

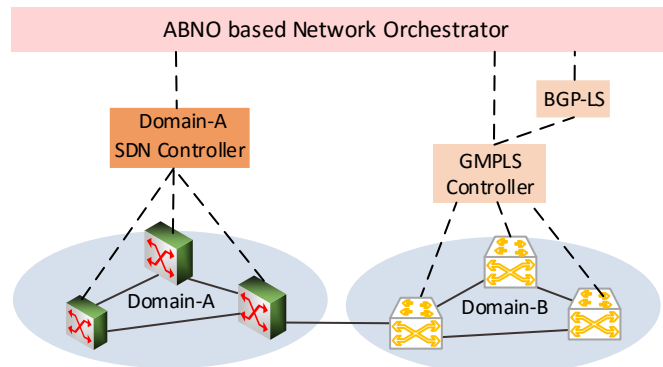

Fig. 23. The application-based network operations (ABNO) based SDN multilayer orchestrator [414] receives the physical topology information from the OpenFlow/GMPLS controllers. The orchestrator centrally computes paths and sends the path information to the lower level controllers for path provisioning.

e) Application-Based Network Operations: Muñoz et al. [414], have presented an SDN orchestration mechanism based on the application-based network operations (ABNO) framework, which is being defined by the IETF [426]. The ABNO based SDN orchestrator integrates OpenFlow and GMPLS in transport networks. Two SDN orchestration designs have been presented: (i) with centralized physical network topology aware path computation (illustrated in Fig. 23), and (ii) with topology abstraction and distributed path computation. In the centralized design, OpenFlow and GMPLS controllers (lower level control) expose the physical topology information to the ABNO-orchestrator (higher level control). The PCE in the ABNO-orchestrator has the global view of the network and can compute end-to-end paths with complete knowledge of the network. Computed paths are then provisioned through the lower level controllers. The pitfalls of such centralized designs are (i) computationally intensive path computations, (ii) continuous updates of topology and traffic information, and (iii) sharing of confidential network information and policies with other network elements. To reduce the computational load at the orchestrator, the second design implements distributed path computation at the lower level controllers (instead of path computation at the centralized orchestrator). However, such distributed mechanisms may lead to suboptimal solutions due to the limited network knowledge.

2) Multidomain Data Center Orchestration:

a) Control Architectures: Geographically distributed DCs are typically interconnected by links traversing multiple domains. The traversed domains may be homogeneous i.e., have the same type of network technology, e.g., OpenFlow based ROADMs, or may be heterogeneous, i.e., have different types of network technologies, e.g., OpenFlow based ROADMs and GMPLS based WSON. The SDN control structures for a multidomain network can be broadly classified into the categories of (i) single SDN orchestrator/controller, (ii) multiple mesh SDN controllers, and (iii) multiple hierarchical SDN controllers [415], [416]. The single SDN orchestrator/controller has to support heterogeneous SBIs in order to operate with multiple heterogeneous domains, e.g., the Path Computation Element Protocol (PCEP) for GMPLS network domains and the OpenFlow protocol for OpenFlow

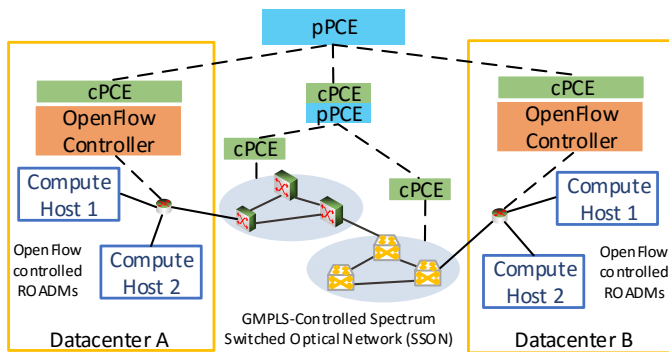

Fig. 24. Illustration of SDN orchestration based on Hierarchical Path Computation Element (H-PCE) [417]: The H-PCE internetworks GMPLS inter-DC communication and OpenFlow intra-DC communication. The parent-PCE (pPCE) aggregates the active PCE states from the child-PCEs (cPCEs) of both GMPLS and OpenFlow.

supported ROADMs. Also, domain specific details, such as topology, as well as network statistics and configurations, have to be exposed to an external entity, namely the single SDN orchestrator/controller, raising privacy concerns. Furthermore, a single controller may result in scalability issues. Mesh SDN control connects the domain-specific controllers side-by-side by extending the east/west bound interfaces. Although mesh SDN control addresses the scalability and privacy issues, the distributed nature of the control mechanisms may lead to sub-optimal solutions. With hierarchical SDN control, a logically centralized controller (parent SDN controller) is placed above the domain-specific controllers (child SDN controllers), extending the north/south bound interfaces. Domain-specific controllers virtualize the underlying networks inside their domains, exposing only the abstracted view of the domains to the parent controller, which addresses the privacy concerns. Centralized path computation at the parent controller can achieve optimal solutions. Multiple hierarchical levels can address the scalability issues. These advantages of hierarchal SDN control are achieved at the expense of an increased number of network entities, resulting in the operational complexities.

b) Hierarchical PCE: Casellas et al. [417] considered DC connectivities involving both intra-DC and inter-DC communications. Intra-DC communications enabled through OpenFlow networks are supported by an OpenFlow controller. The inter-DC communications are enabled by optical transport networks involving more complex control, such as GMPLS, as illustrated in Fig. 24. To achieve the desired SDN benefits of flexibility and scalability, a common centralized control platform spanning across heterogeneous control domains is proposed. More specifically, an Hierarchical PCE (H-PCE) aggregates PCE states from multiple domains. The end-to-end path setup between DCs is orchestrated by a parent-PCE (pPCE) element, while the paths are provisioned by the child-PCEs (cPCEs) on the physical resources, i.e., the OpenFlow and GMPLS domains. The proposed mechanism utilizes existing protocol interfaces, such as BGP-LS and PCEP, which are extended with OpenFlow to support the H-PCE.

c) Virtual-SDN Control: Muñoz et al. [418], [419] proposed a mechanism to virtualize the SDN control functions

in a DC/cloud by integrating SDN with Network Function Virtualization (NFV). In the considered context, NFV refers to realizing network functions by software modules running on generic computing hardware inside a DC; these network functions were conventionally implemented on specialized hardware modules. The orchestration of Virtual Network Functions (VNFs) is enabled by an integrated SDN and NFV management which dynamically instantiates virtual SDN controllers. The virtual SDN controllers control the Virtual Tenant Networks (VTNs), i.e., virtual multidomain and multitechnology networks. Multiple VNFs running on a Virtual Machine (VM) in a DC are managed by a VNF manager. A virtual SDN controller is responsible for creating, managing, and tearing down the VNF achieving the flexibility in the control plane management of the multilayer and the multidomain networks. Additionally, as an extension to the proposed mechanism, the virtualization of the control functions of the LTE Evolved Packet Core (EPC) has been discussed in [427].

C. Orchestration: Summary and Discussion

Relatively few SDN orchestration studies to date have focused on vertical multilayer networking within a given domain. The few studies have developed two general orchestration frameworks and have examined a few orchestration strategies for some specific applications. More specifically, one orchestration framework has focused on optimal bandwidth allocation based mainly on congestion [402], while the other framework has focused on exploiting application traffic tolerances for delays for efficiently routing traffic [407]. SDN orchestration of vertical multilayer optical networking is thus still a relatively little explored area. Future research can develop orchestration frameworks that accommodate the specific optical communication technologies in the various layers and rigorously examine their performance-complexity tradeoffs. Similarly, relatively few applications have been examined to date in the application-specific orchestration studies for vertical multilayer networking [408]–[410]. The examination of the wide range of existing applications and any newly emerging network application in the context of SDN orchestrated vertical multilayer networking presents rich research opportunities. The cross-layer perspective of the SDN orchestrator over a given domain could, for instance, be exploited for strengthening security and privacy mechanisms or for accommodating demanding real-time multimedia.

Relatively more SDN orchestration studies to date have examined multidomain networking than multilayer networking (within a single domain). As the completed multidomain orchestration studies have demonstrated, the SDN orchestration can help greatly in coordinating complex network management decisions across multiple distributed routing domains. The completed studies have illustrated the fundamental tradeoff between centralized decision making in a hierarchical orchestration structure and distributed decision making in a flat orchestration structure. In particular, most studies have focused on hierarchical structures [411], [417], [418], while only one study has mainly focused on a flat orchestration structure [412]. In the context of DC internetworking, the

studies [415], [416] have sought to bring out the tradeoffs between these two structures by examining a range of structures from centralized to distributed. While centralized orchestration can make decisions with a wide knowledge horizon across the states in multiple domains, distributed decision making preserves the privacy of network status information, reduces control traffic, and can make fast localized decisions. Future research needs to shed further light on these complex tradeoffs for a wide range of combinations of optical technologies employed in the various domains. Throughout, it will be critical to abstract and convey the key characteristics of optical physical layer components and switching nodes to the overall orchestration protocols. Optimizing each abstraction step as well as the overall orchestration and examining the various performance tradeoffs are important future research directions.

VIII. OPEN CHALLENGES AND FUTURE SDON RESEARCH DIRECTIONS

We have outlined open challenges and future Software Defined Optical Network (SDON) research directions for each sub-category of surveyed SDON studies in the Summary and Discussion subsections in the preceding survey sections. In this section, we focus on the overall cross-cutting open challenges that span across the preceding considered categories of SDON studies. That is, we focus on open challenges and research directions that span the vertical (inter-layer) and horizontal (inter-domain) SDON aspects. The vertical SDON aspects encompass the seamless integration of the various (vertical) layers of the SDON architecture; especially the optical layer, which is not considered in general SDN technology. The horizontal SDON aspects include the integration of SDONs with existing non-SDN optical networking elements, and the internetworking with other domains, which may have similar or different SDN architectures. A key challenge for SDON research is to enable the use of SDON concepts in operational real-time network infrastructures. Importantly, the SDON concepts need to demonstrate performance gains and cost reductions to be considered by network and service providers. Therefore, we cater some of the open challenges and future directions towards enabling and demonstrating the successful use of SDON in operational networks.

The SDON research and development effort to date have resulted in insights for making the use of SDN in optical transport networks feasible and have demonstrated advantages of SDN based optical network management. However, most network and service providers depend on optical transport to integrate with multiple industries to complete the network infrastructure. Often, network and service providers struggle to integrate hardware components and to provide accessible software management to customers. For example, companies that develop hardware optical components do not always have a complete associated software stack for the hardware components. Thus, network and service providers using the hardware optical components often have to maintain a software development team to integrate the various hardware components through software based management into their network, which is often a costly endeavor. Thus, improving SDN

technology so that it seamlessly integrates with components of various industries and helps the integration of components from various industries is an essential underlying theme for future SDON research.

A. *Simplicity and Efficiency*

Optical network structures typically span heterogeneous devices ranging from the end user nodes and local area networks via ONUs and OLTs in the access networks to edge routers and metro network nodes and on to backbone (core) network infrastructures. These different devices often come from different vendors. The heterogeneity of devices and their vendors often requires manual configuration and maintenance of optical networks. Moreover, different communication technologies typically require the implementation of native functions that are specific to the communication technology characteristics, e.g., the transmission and propagation properties. By centralizing the optical network control in an SDN controller, the SDN networking paradigm creates a unified view of the entire optical network. The specific native functions for specific communication devices can be migrated to the software layer and be implemented by a central node, rather than through manual node-by-node configurations. The central node would typically be readily accessible and could reduce the required physical accesses to distributed devices at their on-site locations. This centralization can simplify the network management and reduce operational expenditures. An important challenge in this central management is the efficient SDN control of components from multiple vendors. Detailed vendor contract specifications of open-source middleware may be needed to efficiently control components from different vendors.

The heterogeneity of devices may reduce the efficiency of network infrastructures due to the required multiple software and hardware modules for a complete networking solution. Future research should investigate efficient mechanisms for making complete networking solutions available for specific use cases. For example, the use of SDON for an access network provider may require multiple SDN controllers co-located within the OLT to enable the control of the access network infrastructure from one central location. While the SDON studies reviewed in this survey have led initial investigations of simple and dynamic network management, future research needs to refine these management strategies and optimize their operation across combinations of network architecture structures and across various network protocol layers. Simplicity is an essential part of this challenge, since overly complicated solutions are generally not deployed due to the risk of high expenditures.

B. *North Bound Interface*

The NorthBound Interface (NBI) comprises the communication from the controller to the applications. This is an important area of future research as applications and their needs are generally the driving force for deploying SDON infrastructures. Any application, such as video on demand, VoIP, file transfer, or peer-to-peer networking, is applied from

the NBI to the SDN controller which consequently conducts the necessary actions to implement the service behaviors on the physical network infrastructure. Applications often require specific service behaviors that need to be implemented on the overall network infrastructure. For example, applications requiring high data rates and reliability, such as Netflix, depend on data centers and the availability of data from servers with highly resilient failure protection mechanisms. The associated management network needs to stack redundant devices as to safeguard against outages. Services are provided as policies through the NBI to the SDN controller, which in turn generates flow rules for the switching devices. These flow rules can be prioritized based on the customer use cases. An important challenge for future NBI research is to provide a simple interface for a wide variety of service deployments without vendor lock-in, as vendor lock-in generally drives costs up. Also, new forms of communication to the controller, in addition to current techniques, such as REpresentational State Transfer (REST) [65] and HTTP, should be researched. Moreover, future research should develop an NBI framework that spans horizontally across multiple controllers, so that service customers are not restricted to using only a single controller.

Future research should examine control mechanisms that optimally exploit the central SDN control to provide simple and efficient mechanisms for automatic network management and dynamic service deployment [428]. The NBI of SDONs is a challenging facet of research and development because of the multitude of interfaces that need to be managed on the physical layer and transport layer. Optical physical layer components and infrastructures require high capital and operational expenditures and their management is generally not associated with network or service providers but rather with optical component/infrastructure vendors. Future research should develop novel Application Program Interfaces (APIs) for optical layer components and infrastructures that facilitate SDN control and are amenable to efficient NBI communication. Essentially, the challenge of efficient NBI communication with the SDN controller should be considered when designing the APIs that interface with the physical optical layer components and infrastructures.

One specific strategy for simplifying network management and operation could be to explore the grouping of control policies of similar service applications, e.g., applications with similar QoS requirements. The grouping can reduce the number of control policies at the expense of slightly coarser granularity of the service offerings. The emerging Intent-Based Networking (IBN) paradigm, which drafts intents for services and policies, can provide a specific avenue for simplifying dynamic automatic configuration and virtualization [429], [430]. Currently network applications are deployed based on how the network should behave for a specific action. For example, for inter domain routing, the Border Gateway Protocol (BGP) is used, and the network gateways are configured to communicate with the BGP protocol. This complicates the provisioning of services that typically require multiple protocols and limits the flexibility of service provisioning. With IBN, the application gives an intent, for example, transferring video

across multiple domains. This intent is then associated with automated dynamic configurations of the network elements to communicate data over the domains using appropriate protocols. The grouping of service policies, such as intents, can facilitate easy and dynamic service provisioning. Intent groups can be described in a graph to simplify the compilation of service policies and to resolve conflicts [431].

C. Reliability, Security, and Privacy

The SDN paradigm is based on a centrally managed network. Faulty behaviors, security infringements, or failures of the control would likely result in extensive disruptions and performance losses that are exacerbated by the centralized nature of the SDN control. Instances of extensive disruptions and losses due to SDN control failures or infringements would likely reduce the trust in SDN deployments. Therefore, it is very important to ensure reliable network operation and to provision for security and privacy of the communication. Hence, reliability, security, and privacy are prominent SDON research challenges. Security in SDON techniques is a fairly open research area, with only few published findings. As a few reviewed studies (see Section VI-D) have explored, the central SDN control can facilitate reliable network service through speeding up failure recovery. The central SDN control can continuously scan the network and the status messages from the network devices. Or, the SDN control can redirect the status messages to a monitoring service that analyzes the data network. Security breaches can be controlled by broadcasting messages from the controller to all affected devices to block traffic in a specific direction. Future research should refine these reliability functions to optimize automated fault and performance diagnostics and reconfigurations for quick failure recovery.

Network failures can either occur within the physical layer infrastructure, or as errors within the higher protocol layers, e.g., in the classical data link (L2), network (L3), or transport (L4) layers. In the context of SDONs, physical layer failures present important future research opportunities. Physical layer devices need to be carefully monitored by sending feedback from the devices to the controller. The research and development on communication between the SDN controller and the network devices has mainly focused on sending flow rules to the network devices while feedback communicated from the devices to the controller has received relatively little attention. For example, there are three types of OpenFlow messages, namely Packet-In, Packet-Out, and Flow-Mod. The Packet-In messages are sent from the OpenFlow switches to the controller, the Packet-Out message is sent from the controller to the device, and the Flow-Mod message is used to modify and monitor the flow rules in the flow table. Future research should examine extensions of the Packet-In message to send specific status updates in support of network and device failure monitoring to the controller. These status messages could be monitored by a dedicated failure monitoring service. The status update messages could be broadly defined to cover a wide range of network management aspects, including system health monitoring and network failure protection.

A related future research direction is to secure configuration and operation of SDONs through trusted encryption and key management systems [27]. Moreover, mechanisms to ensure the privacy of the communication should be explored. The security and privacy mechanisms should strive to exploit the natural immunity of optical transmission segments to electromagnetic interferences.

In summary, security and privacy of SDON communication are largely open research areas. The optical physical layer infrastructure has traditionally not been controlled remotely, which in general reduces the occurrences of security breaches. However, centralized SDN management and control increase the risk of security breaches, requiring extensive research on SDON security, so as to reap the benefits of centralized SDN management and control in a secure manner.

D. Scalability

Optical networks are expensive and used for high-bandwidth services, such as long-distance network access and data center interconnections. Optical network infrastructures either span long distances between multiple geographically distributed locations, or could be short-distance incremental additions (interconnects) of computing devices. Scalability in multiple dimensions is therefore an important aspect for future SDON research. For example, a myriad of tiny end devices need to be provided with network access in the emerging Internet of Things (IoT) paradigm [255]. The IoT requires access network architectures and protocols to scale vertically (across protocol layers and technologies) and horizontally (across network domains). At the same time, the ongoing growth of multimedia services requires data centers to scale up optical network bandwidths to maintain the quality of experience of the multimedia services. Broadly speaking, scalability includes in the vertical dimension the support for multiple network devices and technologies. Scalability in the horizontal direction includes the communication between a large number of different domains as well as support for existing non-SDON infrastructures.

A specific scalability challenge arising with SDN infrastructure is that the scalability of the control plane (OpenFlow protocol signalling) communication and the scalability of the data plane communication which transports the data plane flows need to be jointly considered. For example, the Openflow protocol 1.4 currently supports 34 Flow-Mod messages [432], which can communicate between the network devices and the controller. This number limits the functionality of the SBI communication. Recent studies have explored a protocol-agnostic approach [60], [433], which is a data plane protocol that extends the use of multiple protocols for communication between the control plane and data plane. The protocol-agnostic approach resolves the challenges faced by OpenFlow and, in general, any particular protocol. Exploring this novel protocol-agnostic approach presents many new SDON research directions.

Scalability would also require SDN technology to overlay and scale over existing non-SDN infrastructures. Vendors provide support for known non-SDN devices, but this area

is still a challenge. There are no known protocols that could modify the flow tables of existing popularly described “non-OpenFlow” switches. In the case of optical networks, as SDN is still being incrementally deployed, the overlaying with non-SDN infrastructure still requires significant attention. Ideally, the overlay mechanisms should ensure seamless integration and should scale with the growing deployment of SDN technologies while incurring only low costs. Overall, scalability poses highly important future SDON research directions that require economical solutions.

E. Standardization

Networking protocols have traditionally followed a uniform standard system for all the communication across multiple domains. Standardization has helped vendors to provide products that work in and across different network infrastructures. In order to ensure the compatible inter-operation of SDON components (both hardware and software) from a various vendors, key aspects of the inter-operation protocols need to be standardized. Towards the standardization goal, communities, such as Open Networking Foundation (ONF), have created boards and committees to standardize protocols, such as OpenFlow. Standardization should ensure that SDON infrastructures can be flexibly configured and operated with components from various vendors. The use of open-source software can further facilitate the inter-operation. Proprietary hardware and software components generally create vendor lock-in, which restricts the flexibility of network operation and reduces the innovation of network and service providers.

As groundwork for standardization, it may be necessary to develop and optimize a common (or a small set) of SDON architectures and network protocol configurations that can serve as a basis for standardization efforts. The standardization process may involve a common platform that is built through the cooperation of multiple manufacturers. Another thrust of standardization groundwork could be the development of open-source software that supports SDON architectures. For example, Openstack is a cloud based management framework that has been adopted and supported by multiple networking vendors. Such efforts should be extended to SDONs in future work.

F. Multilayer Networking

As discussed in Section VII, multilayer networking involves vertical multilayer networking across the vertical layers as well as horizontal multilayer (multidomain) networking across multiple domains. We proceed to outline open challenges and future research directions for vertical multilayer networking in the context of SDON, which includes an optical physical layer, in this subsection. Horizontal multilayer (multidomain) networking is considered in Section VIII-G.

For the vertical multilayer networking in a single domain, the optical physical layer is the key distinguishing feature of SDONs compared to conventional SDN architectures for general IP networks. Most of the higher layers in SDONs have similar multilayer networking challenges as general IP networks. However, the optical physical layer requires the

provisioning of specific optical transmission parameters, such as wavelengths and signal strengths. These parameters are managed by optical devices, such as the OLT in PON networks. For SDON networks, so-called *optical orchestrators*, which are commercially available, e.g., from ADVA Optical Networking, provide a single interface to provision the optical layer parameters. We illustrate this optical orchestrator layer in the context of an SDON multilayer network in the rightmost branch of Fig. 2. The optical orchestrator resides above the optical devices and below the SDN controller. The optical orchestrator uses common SDN SBI interface protocols, such as OpenFlow, to communicate with the optical devices in the south-bound direction and with the controller in the north-bound direction.

The SDN controller in the control plane is responsible for the management of the SDN-enabled switches, potentially via an optical orchestrator. Communicating over the SBI using different protocols can be challenging for the controller. This challenge can be addressed by using south-bound renderers. South-bound renderers are APIs that reside within the controller and provide a communication channel to any desired SBI protocol. Most SDN controllers currently have an OpenFlow renderer to be able to communicate to Openflow network switches. But there are also SNMP and NETCONF-based renderers, which communicate with traditional non-OpenFlow switches. This enables the existence of hybrid networks with already existing switches. The effective support of such hybrid networks, in conjunction with appropriate south-bound renderers and optical orchestrators, is an important direction for future research.

G. Multidomain Networks

A network domain usually belongs to a single organization that owns (i.e., financially supports and uses) the network domain. The management of multidomain networking involves the important aspects of configuring the access control as well as the authentication, authorization, and accounting. Efficient SDN control mechanisms for configuring these multidomain networking aspects is an important direction for future research and development.

Multidomain SDONs may also need novel routing algorithm that enhance the capabilities of the currently used BGP protocol. Multidomain research [434] has now taken interest in the Intent-Based Networking (NBI) paradigm for SDN control, where Intent-APIs can solve the problems of spanning across multiple domains. For instance, the intent of an application to transfer information across multiple domains is translated into service instances that access configurations between domains that have been pre-configured based on contracts. Currently, costly manual configurations between domains are required for such applications. Future research needs to develop concrete models for NBI based multidomain networking in SDONs.

H. Fiber-Wireless (FiWi) Networking

The optical (fiber) and wireless network domains have many differences. At the physical layer, wireless networks are characterized by varying channel qualities, potentially high

losses, and generally lower transmission bit rates than optical fiber. Wireless end nodes are typically mobile and may connect dynamically to wireless network domains. The mobile wireless nodes are generally the end-nodes in a FiWi network and connect via intermediate optical nodes to the Internet. Due to these different characteristics, the management of wireless networks with mobile end nodes is very different from the management of optical network nodes. For example, wireless access points should maintain their own routing table to accommodate access to dynamically connected mobile devices. Combining the control of both wireless and optical networks in a single SDN controller requires concrete APIs that handle the respective control functions of wireless and optical networks. Currently, service providers maintain separate physical management services without a unified logical control and management plane for FiWi networks. Developing integrated controls for FiWi networks can be viewed as a special case of multilayer networking and integration.

Developing specialized multilayer networking strategies for FiWi networks is an important future research directions as many aspects of wireless networks have dramatically advanced in recent years. For instance, the cell structure of wireless cellular networks [435] has advanced to femtocell networks [436] as well as heterogeneous and multitier cellular structures [437], [438]. At the same time, machine-to-machine communication [439], [440] and energy savings [441], [442] have drawn research attention.

I. QoS and Energy Efficiency

Different types of applications have vastly different traffic bit rate characteristics and QoS requirements. For instance, streaming high-definition video requires high bit rates, but can tolerate some delays with appropriate playout buffering. On the other hand, VoIP (packet voice) or video conference applications have typically low to moderate bit rates, but require low latencies. Achieving these application-dependent QoS levels in an energy-efficient manner [442]–[444] is an important future research direction. A related future research direction is to exploit SDN control for QoS adaptations of real-time media and broadcasting services. Broadcasting services involve typically data rates ranging from 3–48 Gb/s to deliver video at various resolutions to the users within a reasonable time limit. In addition to managing the QoS, the network has to manage the multicast groups for efficient routing of traffic to the users. Recent studies [445], [446] discuss the potential of SDN, NFV, and optical technologies to achieve the growing demands of broadcasters and media. Moreover, automated provisioning strategies of QoS and the incorporation of quality of protection and security with traditional QoS are important direction for future QoS research in SDONs.

J. Performance Evaluation

Comprehensive performance evaluation methodologies and metrics need to be developed to assess the SDON designs addressing the preceding future research directions ranging from simplicity and efficiency (Section VIII-A) to optical-wireless networks (Section VIII-H). The performance evaluations need

to encompass the data plane, the control plane, as well as the overall data and control plane interactions with the SDN interfaces and need to take virtualization and orchestration mechanisms into consideration. In the case of the SDON infrastructure, the performance evaluations will need include the optical physical layer [447]. While there have been some efforts to develop evaluation frameworks for general SDN switches [448], [449], such evaluation frameworks need to be adapted to the specific characteristics of SDON architectures. Similarly, some evaluation frameworks for general SDN controllers have been explored [450], [451]; these need to be extended to the specific SDON control mechanisms.

Generally, performance metrics obtained with SDN and virtualization mechanisms should be benchmarked against the corresponding conventional network without any SDN or virtualization components. Thus, the performance tradeoffs and costs of the flexibility gained through SDN and virtualization mechanism can be quantified. This quantified data would then need to be assessed and compared in the context of business needs. To identify some of the important aspects of performance we analyze the sample architecture in Fig. 14. The SDN controller in the SDON architecture in Fig. 14 spans across multiple elements, such as ONUs, OLTs, routers/switches in the metro-section, as well as PCEs in the core section. A meaningful performance evaluation of such a network requires comprehensive analysis of data plane performance aspects and related metrics, including noise spectral analysis, bandwidth and link rate monitoring, as well as evaluation of failure resilience. Performance evaluation mechanisms need to be developed to enable the SDON controller to obtain and analyze these performance data. In addition, mechanisms for control layer performance analysis are needed. The control plane performance evaluation should, for instance assess the controller efficiency and performance characteristics, such as the OpenFlow message rates and the rates and delays of flow table management actions.

IX. CONCLUSION

We have presented a comprehensive survey of software defined optical networking (SDON) studies to date. We have mainly organized our survey according to the SDN infrastructure, control, and application layer structure. In addition, we have dedicated sections to SDON virtualization and orchestration studies. Our survey has found that SDON infrastructure studies have examined optical (photonic) transmission and switching components that are suitable for flexible SDN controlled operation. Moreover, flexible SDN controlled switching paradigms and optical performance monitoring frameworks have been investigated.

SDON control studies have developed and evaluated SDN control frameworks for the wide range of optical network transmission approaches and network structures. Virtualization allows for flexible operation of multiple Virtual Optical Networks (VONs) over a given installed physical optical network infrastructure. The surveyed SDON virtualization studies have examined the provisioning of VONs for access networks, exploiting the specific physical and Medium Access

Control (MAC) layer characteristics of access networks. The virtualization studies have also examined the provisioning of VONs in metro and backbone networks, examining algorithms for embedding the VON topologies on the physical network topology under consideration of the optical transmission characteristics.

SDON application layer studies have developed mechanisms for achieving Quality of Service (QoS), access control and security, as well as energy efficiency and failure recovery. SDON orchestration studies have examined coordination mechanisms across multiple layers (in the vertical dimension of the network protocol layer stack) as well as across multiple network domains (that may belong to different organizations).

While the SDON studies to date have established basic principles for incorporating and exploiting SDN control in optical networks, there remain many open research challenges. We have outlined open research challenges for each individual category of studies as well as cross-cutting research challenges.

REFERENCES

- [1] D. Comer, *Automated Network Management Systems*. Pearson/Prentice Hall, 2007.
- [2] F. Hu, Q. Hao, and K. Bao, "A survey on software-defined network and OpenFlow: From concept to implementation," *IEEE Commun. Surv. & Tut.*, vol. 16, no. 4, pp. 2181–2206, 2014.
- [3] S. Jain *et al.*, "B4: Experience with a globally-deployed software defined WAN," *ACM SIGCOMM Computer Commun. Rev.*, vol. 43, no. 4, pp. 3–14, 2013.
- [4] S. J. Vaughan-Nichols, "OpenFlow: The next generation of the network?" *Computer*, vol. 44, no. 8, pp. 13–15, 2011.
- [5] Open Networking Foundation, "SDN Architecture Overview, Version 1.1, ONF TR-504," Palo Alto, CA, USA, Nov. 2014.
- [6] D. Kreutz *et al.*, "Software-defined networking: A comprehensive survey," *Proc. IEEE*, vol. 103, no. 1, pp. 14–76, 2015.
- [7] A. Lara, A. Kolasani, and B. Ramamurthy, "Network innovation using OpenFlow: A survey," *IEEE Commun. Surv. & Tut.*, vol. 16, no. 1, pp. 493–512, 2014.
- [8] R. Enns, M. Bjorklund, J. Schoenwaelder, and A. Bierman, "Network Configuration Protocol (NETCONF)," Internet Requests for Comments, RFC Editor, RFC 6241, Jun. 2011. [Online]. Available: <http://www.rfc-editor.org/rfc/rfc6241.txt>
- [9] "ONOS - a new carrier-grade SDN network operating system designed for high availability, performance, scale-out," 2016. [Online]. Available: <http://onosproject.org/>
- [10] I. F. Akyildiz, A. Lee, P. Wang, M. Luo, and W. Chou, "A roadmap for traffic engineering in SDN-OpenFlow networks," *Computer Networks*, vol. 71, pp. 1–30, 2014.
- [11] T. Chen, M. Matinmikko, X. Chen, X. Zhou, and P. Ahokangas, "Software defined mobile networks: concept, survey, and research directions," *IEEE Commun. Mag.*, vol. 53, no. 11, pp. 126–133, November 2015.
- [12] H. Farhady, H. Lee, and A. Nakao, "Software-defined networking: A survey," *Computer Networks*, vol. 81, pp. 79–95, 2015.
- [13] N. Feamster, J. Rexford, and E. Zegura, "The road to SDN: An intellectual history of programmable networks," *SIGCOMM Comput. Commun. Rev.*, vol. 44, no. 2, pp. 87–98, Apr 2014.
- [14] R. Jain and S. Paul, "Network virtualization and software defined networking for cloud computing: a survey," *IEEE Commun. Mag.*, vol. 51, no. 11, pp. 24–31, 2013.
- [15] Y. Jarraya, T. Madi, and M. Debbabi, "A survey and a layered taxonomy of software-defined networking," *IEEE Commun. Surv. & Tut.*, vol. 16, no. 4, pp. 1955–1980, 2014.
- [16] M. Jarschel, T. Zinner, T. Hossfeld, P. Tran-Gia, and W. Kellerer, "Interfaces, attributes, and use cases: A compass for SDN," *IEEE Commun. Mag.*, vol. 52, no. 6, pp. 210–217, Jun. 2014.
- [17] B. Khasnabish, B.-Y. Choi, and N. Feamster, "JONS: Special issue on management of software-defined networks," *J. Network and Systems Management*, vol. 23, no. 2, pp. 249–251, 2015.

- [18] C. Li *et al.*, "Software defined environments: An introduction," *IBM J. Research and Development*, vol. 58, no. 2/3, pp. 1:1–1:11, Mar. 2014.
- [19] F. A. Lopes, M. Santos, R. Fidalgo, and S. Fernandes, "A software engineering perspective on SDN programmability," *IEEE Commun. Surv. & Tut., In Print*, 2016.
- [20] O. Michel, M. Coughlin, and E. Keller, "Extending the software-defined network boundary," *SIGCOMM Comput. Commun. Rev.*, vol. 44, no. 4, pp. 381–381, Aug. 2014.
- [21] B. Nunes, M. Mendonca, X. Nguyen, K. Obraczka, and T. Turletti, "A survey of software-defined networking: Past, present, and future of programmable networks," *IEEE Commun. Surv. & Tut.*, vol. 16, no. 3, pp. 1617–1634, 2014.
- [22] S. Racherla, D. Cain, S. Irwin, P. Patil, and A. M. Tarenzio, *Implementing IBM Software Defined Network for Virtual Environments*. IBM Redbooks, 2014.
- [23] C. Trois, M. D. D. D. Fabro, L. C. E. deBona, and M. Martinello, "A survey on SDN programming languages: Towards a taxonomy," *IEEE Commun. Surv. & Tut., In Print*, 2016.
- [24] B. J. van Asten, N. L. van Adrichem, and F. A. Kuipers, "Scalability and resilience of software-defined networking: An overview," *arXiv preprint arXiv:1408.6760*, 2014.
- [25] J. A. Wickboldt *et al.*, "Software-defined networking: management requirements and challenges," *IEEE Commun. Mag.*, vol. 53, no. 1, pp. 278–285, 2015.
- [26] W. Xia, Y. Wen, C. Foh, D. Niyato, and H. Xie, "A survey on software-defined networking," *IEEE Commun. Surv. & Tut.*, vol. PP, no. 99, pp. 1–1, 2015.
- [27] I. Ahmad, S. Namal, M. Ylianttila, and A. Gurtov, "Security in software defined networks: A survey," *IEEE Commun. Surv. & Tut.*, vol. 17, no. 4, pp. 2317–2346, 2015.
- [28] S. Scott-Hayward, S. Natarajan, and S. Sezer, "A survey of security in software defined networks," *IEEE Commun. Surv. & Tut.*, vol. 18, no. 1, pp. 623–654, 2016.
- [29] L. Bertaux *et al.*, "Software defined networking and virtualization for broadband satellite networks," *IEEE Commun. Mag.*, vol. 53, no. 3, pp. 54–60, Mar. 2015.
- [30] G. Zhang, M. De Leenheer, A. Morea, and B. Mukherjee, "A survey on OFDM-based elastic core optical networking," *IEEE Commun. Surv. & Tut.*, vol. 15, no. 1, pp. 65–87, 2013.
- [31] P. Bhaumik *et al.*, "Software-defined optical networks (SDONs): a survey," *Photonic Netw. Commun.*, vol. 28, no. 1, pp. 4–18, 2014.
- [32] M. Channegowda, R. Nejabati, and D. Simeonidou, "Software-defined optical networks technology and infrastructure: Enabling software-defined optical network operations [invited]," *IEEE/OSA J. Opt. Commun. Netw.*, vol. 5, no. 10, pp. A274–A282, Oct. 2013.
- [33] L. Liu *et al.*, "Field trial of an OpenFlow-based unified control plane for multilayer multigranularity optical switching networks," *IEEE/OSA J. Lightwave Techn.*, vol. 31, no. 4, pp. 506–514, 2013.
- [34] N. Cvijetic, "SDN for optical access networks," in *Photonics in Switching*, 2014, p. PM3C.4.
- [35] —, "Optical network evolution for 5G mobile applications and SDN-based control," in *Proc. Int. Telecommunications Network Strategy and Planning Symp. (Networks)*, Sep. 2014, pp. 1–5.
- [36] T. Starr, J. M. Cioffi, and P. J. Silverman, *Understanding Digital Subscriber Line Technology*. Prentice Hall, 1999.
- [37] K. Kerpez *et al.*, "Software-defined access networks," *IEEE Commun. Mag.*, vol. 52, no. 9, pp. 152–159, Sep. 2014.
- [38] N. Bitar, "Software Defined Networking and applicability to access networks," in *Proc. OFC*, Mar. 2014, pp. 1–3.
- [39] J. deAlmeida Amazonas, G. Santos-Boada, and J. Sole-Pareta, "A critical review of OpenFlow/SDN-based networks," in *Proc. Int. Conf. on Transparent Optical Netw. (ICTON)*, Jul. 2014, pp. 1–5.
- [40] M. Arslan, K. Sundaresan, and S. Rangarajan, "Software-defined networking in cellular radio access networks: potential and challenges," *IEEE Commun. Mag.*, vol. 53, no. 1, pp. 150–156, Jan. 2015.
- [41] C. J. Bernardos *et al.*, "An architecture for software defined wireless networking," *IEEE Wireless Commun.*, vol. 21, no. 3, pp. 52–61, 2014.
- [42] I. T. Haque and N. Abu-Ghazaleh, "Wireless software defined networking: a survey and taxonomy," *IEEE Commun. Surv. & Tut., in print*, 2016.
- [43] N. A. Jagadeesan and B. Krishnamachari, "Software-defined networking paradigms in wireless networks: a survey," *ACM Comp. Surv.*, vol. 47, no. 2, pp. 27.1–27.11, 2014.
- [44] M. Sama *et al.*, "Software-defined control of the virtualized mobile packet core," *IEEE Commun. Mag.*, vol. 53, no. 2, pp. 107–115, Feb. 2015.
- [45] K. Sood, S. Yu, and Y. Xiang, "Software defined wireless networking opportunities and challenges for internet of things: A review," *IEEE Internet of Things Journal, in print*, 2016.
- [46] M. Yang *et al.*, "Software-defined and virtualized future mobile and wireless networks: A survey," *Mobile Netw. and Appl.*, pp. 1–15, 2015.
- [47] C. Liang and F. Yu, "Wireless network virtualization: A survey, some research issues and challenges," *IEEE Commun. Surv. & Tut.*, vol. 17, no. 1, pp. 358–380, First Qu. 2015.
- [48] I. Khan *et al.*, "Wireless sensor network virtualization: A survey," *IEEE Network*, vol. 29, no. 3, pp. 104–112, 2015.
- [49] C. Liang and F. R. Yu, "Wireless network virtualization: A survey, some research issues and challenges," *IEEE Commun. Surv. & Tut.*, vol. 17, no. 1, pp. 358–380, 2015.
- [50] V.-G. Nguyen, T.-X. Do, and Y. Kim, "SDN and virtualization-based LTE mobile network architectures: A comprehensive survey," *Wireless Personal Commun.*, vol. 86, no. 3, pp. 1401–1438, 2016.
- [51] Huawei Technologies, "SoftCOM - The Way to Reconstruct the Future Telecom Industry," 2014. [Online]. Available: http://www.huawei.com/mwc2014/en/articles/hw-u_319945.htm
- [52] M. Peng, Y. Li, Z. Zhao, and C. Wang, "System architecture and key technologies for 5G heterogeneous cloud radio access networks," *arXiv preprint arXiv:1412.6677*, 2014.
- [53] R. Trivisonno, R. Guerzoni, I. Vaishnavi, and D. Soldani, "SDN-based 5G mobile networks: architecture, functions, procedures and backward compatibility," *Trans. Emerging Telecommun. Techn.*, vol. 26, no. 1, pp. 82–92, 2015.
- [54] V. Yazici, U. Kozat, and M. Oguz Sunay, "A new control plane for 5G network architecture with a case study on unified handoff, mobility, and routing management," *IEEE Commun. Mag.*, vol. 52, no. 11, pp. 76–85, Nov. 2014.
- [55] E. Haleplidis *et al.*, "Software-Defined Networking (SDN): Layers and Architecture Terminology," Internet Requests for Comments, RFC Editor, RFC 7426, Jan. 2015. [Online]. Available: <http://www.rfc-editor.org/rfc/rfc7426.txt>
- [56] F. Hu, Q. Hao, and K. Bao, "A survey on software-defined network and OpenFlow: From concept to implementation," *IEEE Commun. Surv. & Tut.*, vol. 16, no. 4, pp. 2181–2206, Fourthquarter 2014.
- [57] N. McKeown *et al.*, "OpenFlow: enabling innovation in campus networks," *ACM SIGCOMM Computer Commun. Rev.*, vol. 38, no. 2, pp. 69–74, 2008.
- [58] Open Networking Foundation, "SDN Architecture, Issue 1.1, ONF TR-521," Palo Alto, CA, USA, 2016.
- [59] L. Yang, R. Dantu, T. Anderson, and R. Gopal, "Forwarding and Control Element Separation (ForCES) Framework," Internet Requests for Comments, RFC Editor, RFC 3746, Apr. 2004. [Online]. Available: <http://www.rfc-editor.org/rfc/rfc3746.txt>
- [60] P. Bosshart *et al.*, "P4: Programming protocol-independent packet processors," *ACM SIGCOMM Computer Commun. Rev.*, vol. 44, no. 3, pp. 87–95, 2014.
- [61] H. Song, "Protocol-oblivious forwarding: Unleash the power of SDN through a future-proof forwarding plane," in *Proc. ACM SIGCOMM Wkps. on Hot Topics in SDN*, 2013, pp. 127–132.
- [62] "Cisco DevNet: onePK," 2016. [Online]. Available: <https://developer.cisco.com/site/onepk/>
- [63] "Cord (central office re-architected as a datacenter): the killer app for SDN & NFV," 2016. [Online]. Available: <http://opencord.org/>
- [64] D. Fellows and D. Jones, "Docsis tm cable modem technology," *IEEE Commun. Mag.*, vol. 39, no. 3, pp. 202–209, Mar 2001.
- [65] C. Severance, "Roy T. Fielding: Understanding the REST style," *IEEE Computer*, vol. 48, no. 6, pp. 7–9, Jun. 2015.
- [66] L. Li, W. Chou, W. Zhou, and M. Luo, "Design patterns and extensibility of rest api for networking applications," *IEEE Trans. on Net. and Service Manag.*, vol. 13, no. 1, pp. 154–167, March 2016.
- [67] A. Farrel, J.-P. Vasseur, and J. Ash, "A Path Computation Element (PCE)-Based Architecture," Internet Requests for Comments, RFC Editor, RFC 4655, Aug. 2006. [Online]. Available: <http://www.rfc-editor.org/rfc/rfc4655.txt>
- [68] J. Vasseur and J. L. Roux, "Path Computation Element (PCE) Communication Protocol (PCEP)," Internet Requests for Comments, RFC Editor, RFC 5440, Mar. 2009. [Online]. Available: <http://www.rfc-editor.org/rfc/rfc5440.txt>
- [69] R. P. Goldberg, "Survey of virtual machine research," *IEEE Computer*, vol. 7, no. 6, pp. 34–45, 1974.
- [70] F. Douglass and O. Krieger, "Virtualization," *IEEE Internet Computing*, vol. 17, no. 2, pp. 6–9, 2013.

- [71] A. Belbekkouche, M. Hasan, and A. Karmouch, "Resource discovery and allocation in network virtualization," *IEEE Commun. Surv. & Tut.*, vol. 14, no. 4, pp. 1114–1128, 2012.
- [72] Q. Duan, Y. Yan, and A. V. Vasilakos, "A survey on service-oriented network virtualization toward convergence of networking and cloud computing," *IEEE Trans. Network and Service Management*, vol. 9, no. 4, pp. 373–392, 2012.
- [73] A. Fischer, J. F. Botero, M. Till Beck, H. De Meer, and X. Hesselbach, "Virtual network embedding: A survey," *IEEE Commun. Surv. & Tut.*, vol. 15, no. 4, pp. 1888–1906, 2013.
- [74] B. Han, V. Gopalakrishnan, L. Ji, and S. Lee, "Network function virtualization: Challenges and opportunities for innovations," *IEEE Commun. Mag.*, vol. 53, no. 2, pp. 90–97, 2015.
- [75] A. Leon-Garcia and L. G. Mason, "Virtual network resource management for next-generation networks," *IEEE Commun. Mag.*, vol. 41, no. 7, pp. 102–109, 2003.
- [76] R. Mijumbi *et al.*, "Network function virtualization: State-of-the-art and research challenges," *IEEE Commun. Surv. & Tut.*, vol. 18, no. 1, pp. 236–262, 2016.
- [77] K. Pentikousis *et al.*, "Guest editorial: Network and service virtualization," *IEEE Commun. Mag.*, vol. 53, no. 2, pp. 88–89, 2015.
- [78] R. Jain and S. Paul, "Network virtualization and software defined networking for cloud computing: a survey," *IEEE Commun. Mag.*, vol. 51, no. 11, pp. 24–31, Nov. 2013.
- [79] A. Wang, M. Iyer, R. Dutta, G. N. Rouskas, and I. Baldine, "Network virtualization: technologies, perspectives, and frontiers," *IEEE/OSA J. Lightwave Techn.*, vol. 31, no. 4, pp. 523–537, 2013.
- [80] A. Khan, A. Zugenmaier, D. Jurca, and W. Kellerer, "Network virtualization: a hypervisor for the Internet?" *IEEE Commun. Mag.*, vol. 50, no. 1, pp. 136–143, 2012.
- [81] R. Sherwood *et al.*, "Flowvisor: A network virtualization layer," *OpenFlow Switch Consortium, Tech. Rep.*, 2009.
- [82] A. Blenk, A. Basta, M. Reisslein, and W. Kellerer, "Survey on network virtualization hypervisors for software defined networking," *IEEE Commun. Surv. & Tut.*, vol. 18, no. 1, pp. 655–685, 2016.
- [83] D. Drutskey, E. Keller, and J. Rexford, "Scalable network virtualization in software-defined networks," *IEEE Internet Computing*, vol. 17, no. 2, pp. 20–27, 2013.
- [84] H. Hawilo, A. Shami, M. Mirahmadi, and R. Asal, "NFV: state of the art, challenges, and implementation in next generation mobile networks (vEPC)," *IEEE Network*, vol. 28, no. 6, pp. 18–26, 2014.
- [85] Y. Li and M. Chen, "Software-defined network function virtualization: A survey," *IEEE Access*, vol. 3, pp. 2542–2553, 2015.
- [86] J. Matias, J. Garay, N. Toledo, J. Unzilla, and E. Jacob, "Toward an SDN-enabled NFV architecture," *IEEE Commun. Mag.*, vol. 53, no. 4, pp. 187–193, 2015.
- [87] R. Mijumbi *et al.*, "Network function virtualization: State-of-the-art and research challenges," *IEEE Commun. Surv. & Tut.*, vol. 18, no. 1, pp. 236–262, Firstquarter 2016.
- [88] X. Gong, L. Guo, Y. Liu, Y. Zhou, and H. Li, "Optimization mechanisms in multi-dimensional and flexible PONs: Challenging issues and possible solutions," *Opt. Sw. Netw.*, vol. 18, no. Part 1, pp. 120–134, Nov. 2015.
- [89] J. Jue, V. Eramo, V. López, and Z. Zhu, "Software-defined elastic optical networks," *Photonic Netw. Commun.*, vol. 28, no. 1, pp. 1–3, 2014.
- [90] I. Tomkos, S. Azodolmolky, J. Sole-Pareta, D. Careglio, and E. Palkopoulou, "A tutorial on the flexible optical networking paradigm: State of the art, trends, and research challenges," *Proc. IEEE*, vol. 102, no. 9, pp. 1317–1337, Sep. 2014.
- [91] B. Chatterjee, N. Sarma, and E. Oki, "Routing and spectrum allocation in elastic optical networks: A tutorial," *IEEE Commun. Surv. & Tut.*, vol. 17, no. 3, pp. 1776–1800, 2015.
- [92] S. Talebi *et al.*, "Spectrum management techniques for elastic optical networks: A survey," *Opt. Sw. Netw.*, vol. 13, pp. 34–48, 2014.
- [93] X. Yu *et al.*, "Spectrum engineering in flexible grid data center optical networks," *Opt. Sw. Netw.*, vol. 14, pp. 282–288, 2014.
- [94] O. Gerstel, M. Jinno, A. Lord, and S. J. B. Yoo, "Elastic optical networking: a new dawn for the optical layer?" *IEEE Commun. Mag.*, vol. 50, no. 2, pp. S12–S20, Feb. 2012.
- [95] R. Ramaswami, K. Sivarajan, and G. Sasaki, *Optical Networks: A Practical Perspective*. Morgan Kaufmann, 2009.
- [96] J. M. Simmons, *Optical Network Design and Planning*. Springer, 2014.
- [97] M. Forzati *et al.*, "Next-generation optical access seamless evolution: Concluding results of the European FP7 Project OASE," *IEEE/OSA J. Opt. Commun. Netw.*, vol. 7, no. 2, pp. 109–123, 2015.
- [98] M. Hajduczenia, H. J. daSilva, and P. P. Monteiro, "EPON versus APON and GPON: a detailed performance comparison," *OSA J. Opt. Networking*, vol. 5, no. 4, pp. 298–319, 2006.
- [99] B. Skubic, J. Chen, J. Ahmed, L. Wosinska, and B. Mukherjee, "A comparison of dynamic bandwidth allocation for EPON, GPON, and next-generation TDM PON," *IEEE Commun. Mag.*, vol. 47, no. 3, pp. S40–S48, 2009.
- [100] B. Kantarci and H. T. Mouftah, "Bandwidth distribution solutions for performance enhancement in long-reach passive optical networks," *IEEE Commun. Surv. & Tut.*, vol. 14, no. 3, pp. 714–733, 2012.
- [101] M. P. McGarry and M. Reisslein, "Investigation of the DBA algorithm design space for EPONs," *IEEE/OSA J. Lightwave Techn.*, vol. 30, no. 14, pp. 2271–2280, Jul. 2012.
- [102] J. Zheng and H. T. Mouftah, "A survey of dynamic bandwidth allocation algorithms for Ethernet Passive Optical Networks," *Opt. Sw. Netw.*, vol. 6, no. 3, pp. 151–162, 2009.
- [103] H. Song, B.-W. Kim, and B. Mukherjee, "Long-reach optical access networks: A survey of research challenges, demonstrations, and bandwidth assignment mechanisms," *IEEE Commun. Surv. & Tut.*, vol. 12, no. 1, pp. 112–123, 2010.
- [104] N. Ghazisaidi, M. Maier, and C. M. Assi, "Fiber-wireless (FiWi) access networks: A survey," *IEEE Commun. Mag.*, vol. 47, no. 2, pp. 160–167, 2009.
- [105] N. Ghazisaidi and M. Maier, "Fiber-wireless (FiWi) access networks: Challenges and opportunities," *IEEE Network*, vol. 25, no. 1, pp. 36–42, 2011.
- [106] J. Liu *et al.*, "New perspectives on future smart FiWi networks: Scalability, reliability and energy efficiency," *IEEE Commun. Surv. & Tut.*, in print, 2016.
- [107] A. G. Sariaggiandis *et al.*, "Architectures and bandwidth allocation schemes for hybrid wireless-optical networks," *IEEE Commun. Surv. & Tut.*, vol. 17, no. 1, pp. 427–468, 2015.
- [108] T. Tsagklas and F. Pavlidou, "A survey on radio-and-fiber FiWi network architectures," *J. Selected Areas Telecommun.*, pp. 18–24, Mar. 2011.
- [109] E. I. Gurrola, M. P. McGarry, Y. Luo, and F. Effenberger, "PON/xDSL hybrid access networks," *Opt. Sw. Netw.*, vol. 14, pp. 32–42, 2014.
- [110] M. Chen, J. Wan, S. González, X. Liao, and V. Leung, "A survey of recent developments in home M2M networks," *IEEE Commun. Surv. & Tut.*, vol. 16, no. 1, pp. 98–114, 2014.
- [111] F. Capozzi, G. Piro, L. A. Grieco, G. Boggia, and P. Camarda, "Downlink packet scheduling in LTE cellular networks: Key design issues and a survey," *IEEE Commun. Surv. & Tut.*, vol. 15, no. 2, pp. 678–700, 2013.
- [112] A. Damjanovic *et al.*, "A survey on 3GPP heterogeneous networks," *IEEE Wireless Commun.*, vol. 18, no. 3, pp. 10–21, 2011.
- [113] S. Schwarz *et al.*, "Pushing the limits of LTE: A survey on research enhancing the standard," *IEEE Access*, vol. 1, pp. 51–62, 2013.
- [114] J. Li, M. Peng, A. Cheng, Y. Yu, and C. Wang, "Resource allocation optimization for delay-sensitive traffic in fronthaul constrained cloud radio access networks," *IEEE Systems Journal*, in print, 2016.
- [115] C. Liu *et al.*, "A Novel Multi-Service Small-Cell Cloud Radio Access Network for Mobile Backhaul and Computing Based on Radio-Over-Fiber Technologies," *IEEE/OSA J. Lightwave Techn.*, vol. 31, no. 17, pp. 2869–2875, Sep. 2013.
- [116] S. Park, O. Simeone, O. Sahin, and S. Shamai Shitz, "Fronthaul compression for cloud radio access networks: Signal processing advances inspired by network information theory," *IEEE Signal Proc. Mag.*, vol. 31, no. 6, pp. 69–79, 2014.
- [117] M. Peng, C. Wang, V. Lau, and H. V. Poor, "Fronthaul-Constrained Cloud Radio Access Networks: Insights and Challenges," *IEEE Wireless Commun.*, vol. 22, no. 2, pp. 152–160, Apr. 2015.
- [118] H. Raza, "A brief survey of radio access network backhaul evolution: Part II," *IEEE Commun. Mag.*, vol. 51, no. 5, pp. 170–177, 2013.
- [119] O. Tiptongkolsilp, S. Zaghoul, and A. Jukan, "The evolution of cellular backhaul technologies: current issues and future trends," *IEEE Commun. Surv. & Tut.*, vol. 13, no. 1, pp. 97–113, 2011.
- [120] M. Yang *et al.*, "OpenRAN: a software-defined RAN architecture via virtualization," *ACM SIGCOMM Computer Commun. Rev.*, vol. 43, no. 4, pp. 549–550, 2013.
- [121] I. F. Akyildiz, X. Wang, and W. Wang, "Wireless mesh networks: a survey," *Computer Networks*, vol. 47, no. 4, pp. 445–487, 2005.
- [122] E. Alotaibi and B. Mukherjee, "A survey on routing algorithms for wireless ad-hoc and mesh networks," *Computer Networks*, vol. 56, no. 2, pp. 940–965, 2012.
- [123] D. Benyamina, A. Hafid, and M. Gendreau, "Wireless mesh networks design: a survey," *IEEE Commun. Surv. & Tut.*, vol. 14, no. 2, pp. 299–310, 2012.

- [124] M. S. Kuran and T. Tugcu, "A survey on emerging broadband wireless access technologies," *Computer Networks*, vol. 51, no. 11, pp. 3013–3046, 2007.
- [125] P. H. Pathak and R. Dutta, "A survey of network design problems and joint design approaches in wireless mesh networks," *IEEE Commun. Surv. & Tut.*, vol. 13, no. 3, pp. 396–428, 2011.
- [126] K. S. Vijayalayan, A. Harwood, and S. Karunasekera, "Distributed scheduling schemes for wireless mesh networks: A survey," *ACM Comp. Surv.*, vol. 46, no. 1, pp. 14.1–14.34, 2013.
- [127] Y. Cai, Y. Yan, Z. Zhang, and Y. Yang, "Survey on converged data center networks with DCB and FCoE: standards and protocols," *IEEE Network*, vol. 27, no. 4, pp. 27–32, 2013.
- [128] C. Kachris and I. Tomkos, "A survey on optical interconnects for data centers," *IEEE Commun. Surv. & Tut.*, vol. 14, no. 4, pp. 1021–1036, 2012.
- [129] J. Zhang, F. Ren, and C. Lin, "Survey on transport control in data center networks," *IEEE Network*, vol. 27, no. 4, pp. 22–26, 2013.
- [130] A. Bianco, T. Bonald, D. Cuda, and R.-M. Indre, "Cost, power consumption and performance evaluation of metro networks," *IEEE/OSA J. Opt. Commun. Netw.*, vol. 5, no. 1, pp. 81–91, 2013.
- [131] A. Bianco, D. Cuda, and J. M. Finochietto, "Short-term fairness in slotted WDM rings," *Computer Networks*, vol. 83, pp. 235–248, 2015.
- [132] I.-F. Chao and M. Yuang, "Toward wireless backhaul using circuit emulation over optical packet-switched metro WDM ring network," *IEEE/OSA J. Lightwave Techn.*, vol. 31, no. 18, pp. 3032–3042, 2013.
- [133] C. Rottondi, M. Tornatore, A. Pattavina, and G. Gavioli, "Routing, modulation level, and spectrum assignment in optical metro ring networks using elastic transceivers," *IEEE/OSA J. Opt. Commun. Netw.*, vol. 5, no. 4, pp. 305–315, 2013.
- [134] A. Autenrieth *et al.*, "Evaluation of technology options for software-defined transceivers in fixed WDM grid versus flexible WDM grid optical transport networks," in *Proc. VDE ITG Symposium Photonic Netw.s*, 2013, pp. 1–5.
- [135] J.-P. Elbers and A. Autenrieth, "From static to software-defined optical networks," in *Proc. IEEE Int. Conf. on Optical Network Design and Modeling (ONDM)*, 2012, pp. 1–4.
- [136] S. Gringeri, B. Basch, V. Shukla, R. Egorov, and T. J. Xia, "Flexible architectures for optical transport nodes and networks," *IEEE Commun. Mag.*, vol. 48, no. 7, pp. 40–50, 2010.
- [137] H. Y. Choi, L. Liu, T. Tsuritani, and I. Morita, "Demonstration of BER-adaptive WSON employing flexible transmitter/receiver with an extended OpenFlow-based control plane," *IEEE Photonics Techn. Lett.*, vol. 25, no. 2, pp. 119–121, Jan 2013.
- [138] L. Liu *et al.*, "Demonstration of a dynamic transparent optical network employing flexible transmitters/receivers controlled by an openflow-stateless PCE integrated control plane [invited]," *IEEE/OSA J. Opt. Commun. Netw.*, vol. 5, no. 10, pp. A66–A75, Oct 2013.
- [139] J. Lazaro *et al.*, "Flexible PON key technologies: Digital advanced modulation formats and devices," in *Proc. Int. Conf. on Transparent Optical Networks (ICTON)*, Jul. 2014, pp. 1–5.
- [140] N. Iiyama, S.-Y. Kim, T. Shimada, S. Kimura, and N. Yoshimoto, "Co-existent downstream scheme between OOK and QAM signals in an optical access network using software-defined technology," in *Proc. OFC/NFOEC*, Mar. 2012, pp. 1–3.
- [141] C.-H. Yeh *et al.*, "Using OOK modulation for symmetric 40-Gb/s long-reach time-sharing passive optical networks," *IEEE Photonics Techn. Lett.*, vol. 22, no. 9, pp. 619–621, 2010.
- [142] J. Yu, M.-F. Huang, D. Qian, L. Chen, and G.-K. Chang, "Centralized lightwave WDM-PON employing 16-QAM intensity modulated OFDM downstream and OOK modulated upstream signals," *IEEE Photonics Techn. Lett.*, vol. 20, no. 18, pp. 1545–1547, 2008.
- [143] F. Vacondio *et al.*, "Flexible TDMA access optical networks enabled by burst-mode software defined coherent transponders," in *Proc. Eu. Conf. and Exhibition on Optical Commun. (ECOC)*, Sep. 2013, pp. 1–3.
- [144] M. Bolea, R. Giddings, and J. Tang, "Digital orthogonal filter-enabled optical OFDM channel multiplexing for software-reconfigurable elastic PONs," *IEEE/OSA J. Lightwave Techn.*, vol. 32, no. 6, pp. 1200–1206, 2014.
- [145] M. Bolea, R. P. Giddings, M. Bouich, C. Aupetit-Berthelemon, and J. M. Tang, "Digital filter multiple access PONs with DSP-enabled software reconfigurability," *IEEE/OSA J. Opt. Commun. Netw.*, vol. 7, no. 4, pp. 215–222, April 2015.
- [146] A. Malacarne *et al.*, "Multiplexing of asynchronous and independent ASK and PSK transmissions in SDN-controlled intra-data center network," *IEEE/OSA J. Lightwave Techn.*, vol. 32, no. 9, pp. 1794–1800, May 2014.
- [147] M. Jinno, H. Takara, Y. Sone, K. Yonenaga, and A. Hirano, "Multiflow optical transponder for efficient multilayer optical networking," *IEEE Commun. Mag.*, vol. 50, no. 5, pp. 56–65, 2012.
- [148] N. Sambo *et al.*, "Programmable transponder, code and differentiated filter configuration in elastic optical networks," *IEEE/OSA J. Lightwave Techn.*, vol. 32, no. 11, pp. 2079–2086, June 2014.
- [149] —, "Next generation sliceable bandwidth variable transponders," *IEEE Commun. Mag.*, vol. 53, no. 2, pp. 163–171, 2015.
- [150] —, "Sliceable transponder architecture including multiwavelength source," *IEEE/OSA J. Opt. Commun. Netw.*, vol. 6, no. 7, pp. 590–600, 2014.
- [151] M. S. Moreolo *et al.*, "SDN-enabled sliceable BVT based on multicarrier technology for multiflow rate/distance and grid adaptation," *IEEE/OSA J. Lightwave Techn.*, vol. 34, no. 6, pp. 1516–1522, March 2016.
- [152] Y. Ou *et al.*, "Demonstration of virtualizeable and software-defined optical transceiver," *IEEE/OSA J. Lightwave Techn.*, vol. 34, no. 8, pp. 1916–1924, April 2016.
- [153] C. Matrakidis, T. G. Orphanoudakis, A. Stavdas, J. P. Fernandez-Palacios Gimenez, and A. Manzalini, "HYDRA: A scalable ultra long reach/high capacity access network architecture featuring lower cost and power consumption," *IEEE/OSA J. Lightwave Techn.*, vol. 33, no. 2, pp. 339–348, 2015.
- [154] N. Amaya *et al.*, "Fully-elastic multi-granular network with space/frequency/time switching using multi-core fibres and programmable optical nodes," *OSA Optics Express*, vol. 21, no. 7, pp. 8865–8872, 2013.
- [155] —, "Software defined networking (SDN) over space division multiplexing (SDM) optical networks: features, benefits and experimental demonstration," *OSA Optics Express*, vol. 22, no. 3, pp. 3638–3647, 2014.
- [156] J. M. Galve, I. Gasulla, S. Sales, and J. Capmany, "Reconfigurable radio access networks using multicore fibers," *IEEE/OSA J. Quantum Electronics*, vol. 52, no. 1, pp. 1–7, Jan 2016.
- [157] B. Collings, "New devices enabling software-defined optical networks," *IEEE Commun. Mag.*, vol. 51, no. 3, pp. 66–71, 2013.
- [158] N. Amaya, G. Zervas, and D. Simeonidou, "Introducing node architecture flexibility for elastic optical networks," *IEEE/OSA J. Opt. Commun. Netw.*, vol. 5, no. 6, pp. 593–608, 2013.
- [159] B. R. Rofoee, G. Zervas, Y. Yan, N. Amaya, and D. Simeonidou, "All programmable and synthetic optical network: Architecture and implementation," *IEEE/OSA J. Opt. Commun. Netw.*, vol. 5, no. 9, pp. 1096–1110, 2013.
- [160] R. Younce, J. Larikova, and Y. Wang, "Engineering 400G for colorless-directionless-contentionless architecture in metro/regional networks [invited]," *IEEE/OSA J. Opt. Commun. Netw.*, vol. 5, no. 10, pp. A267–A273, 2013.
- [161] W. I. Way, P. N. Ji, and A. N. Patel, "Wavelength contention-free via optical bypass within a colorless and directionless ROADM [invited]," *IEEE/OSA J. Opt. Commun. Netw.*, vol. 5, no. 10, pp. A220–A229, 2013.
- [162] M. Garrich *et al.*, "Experimental demonstration of function programmable add/drop architecture for ROADMs [invited]," *IEEE/OSA J. Opt. Commun. Netw.*, vol. 7, no. 2, pp. A335–A343, February 2015.
- [163] A. Sadasivarao *et al.*, "Open transport switch: a software defined networking architecture for transport networks," in *Proc. ACM SIGCOMM Workshop on Hot Topics in Software Defined Networking*, 2013, pp. 115–120.
- [164] A. Panda, S. Shenker, M. McCauley, T. Koponen, and M. Casado, "Extending SDN to large-scale networks," in *Proc. ONS13 Research Track*, Apr. 2013.
- [165] R. Nejabati, S. Peng, B. Gou, M. Channegowda, and D. Simeonidou, "Toward a completely softwareized optical network [invited]," *IEEE/OSA J. Opt. Commun. Netw.*, vol. 7, no. 12, pp. B222–B231, Dec 2015.
- [166] S. S. W. Lee, K. Y. Li, and M. S. Wu, "Design and implementation of a GPON-based virtual OpenFlow-enabled SDN switch," *IEEE/OSA J. Lightwave Techn.*, vol. 34, no. 10, pp. 2552–2561, 2016.
- [167] R. Gu, Y. Ji, P. Wei, and S. Zhang, "Software defined flexible and efficient passive optical networks for intra-datacenter communications," *Opt. Sw. Netw.*, vol. 14, pp. 289–302, 2014.
- [168] A. Amokrane, J. Hwang, J. Xiao, and N. Anerousis, "Software defined enterprise passive optical network," in *Proc. IEEE Int. Conf. on Network and Service Management*, Nov 2014, pp. 406–411.
- [169] A. Amokrane, J. Xiao, J. Hwang, and N. Anerousis, "Dynamic capacity management and traffic steering in enterprise passive optical

- networks,” in *Proc. IFIP/IEEE Int. Symposium on Integrated Network Management (IM)*, 2015, pp. 406–413.
- [170] C. H. Yeh, C. W. Chow, M. H. Yang, and D. Z. Hsu, “A flexible and reliable 40-Gb/s OFDM downstream TWDM-PON architecture,” *IEEE Photonics Journ.*, vol. 7, no. 6, pp. 1–9, Dec 2015.
- [171] M. Forzati and A. Gavler, “Flexible next-generation optical access,” in *Proc. Int. Conf. on Transp. Opt. Netw. (ICTON)*, Jun. 2013, pp. 1–8.
- [172] K. Kondepudi, A. Sgambelluri, L. Valcarenghi, F. Cugini, and P. Castoldi, “An SDN-based integration of green TWDM-PONs and metro networks preserving end-to-end delay,” in *Proc. OSA OFC*, 2015, pp. Th2A–62.
- [173] S. Das, G. Parulkar, and N. McKeown, “Unifying packet and circuit switched networks,” in *Proc. IEEE GLOBECOM Workshops*, Nov. 2009, pp. 1–6.
- [174] S. Das *et al.*, “Packet and circuit network convergence with OpenFlow,” in *Proc. OFC/NFOEC*, Mar. 2010, pp. 1–3.
- [175] R. Veisllari, S. Bjornstad, and K. Bozorgebrahimi, “Integrated packet/circuit hybrid network field trial with production traffic [invited],” *IEEE/OSA J. Opt. Commun. Netw.*, vol. 5, no. 10, pp. A257–A266, Oct. 2013.
- [176] S. Azodolmolky *et al.*, “Integrated OpenFlow–GMPLS control plane: an overlay model for software defined packet over optical networks,” *Opt. Express*, vol. 19, no. 26, pp. B421–B428, Dec. 2011.
- [177] M. Shirazipour, W. John, J. Kempf, H. Green, and M. Tatipamula, “Realizing packet-optical integration with SDN and OpenFlow 1.1 extensions,” in *Proc. IEEE ICC*, Jun. 2012, pp. 6633–6637.
- [178] C. Kachris and I. Tomkos, “A survey on optical interconnects for data centers,” *IEEE Commun. Surv. & Tut.*, vol. 14, no. 4, pp. 1021–1036, 2012.
- [179] W. Cerroni, G. Leli, and C. Raffaelli, “Design and test of a software defined hybrid network architecture,” in *Proc. Workshop on High Performance and Programmable Netw. (HPPN)*, 2013, pp. 1–8.
- [180] S. Yin *et al.*, “UltraFlow access testbed: Experimental exploration of dual-mode access networks,” *IEEE/OSA J. Opt. Commun. Netw.*, vol. 5, no. 12, pp. 1361–1372, 2013.
- [181] T. S. R. Shen, S. Yin, A. R. Dhaini, and L. G. Kazovsky, “Reconfigurable long-reach UltraFlow access network: A flexible, cost-effective, and energy-efficient solution,” *IEEE/OSA J. Lightwave Techn.*, vol. 32, no. 13, pp. 2353–2363, 2014.
- [182] S. Yin *et al.*, “A novel quasi-passive, software-defined, and energy efficient optical access network for adaptive intra-PON flow transmission,” *IEEE/OSA J. Lightwave Techn.*, vol. 33, no. 22, pp. 4536–4546, Nov 2015.
- [183] N. Cvijetic, “Software-defined optical access networks for multiple broadband access solutions,” in *Proc. OptoElectronics and Commun. Conf. held jointly with Int. Conf. on Photonics in Switching (OECC/PS)*, Jun. 2013, pp. 1–2.
- [184] N. Cvijetic *et al.*, “SDN and OpenFlow for dynamic flex-grid optical access and aggregation networks,” *IEEE/OSA J. Lightwave Techn.*, vol. 32, no. 4, pp. 864–870, Feb. 2014.
- [185] J. Oliveira *et al.*, “Experimental testbed of reconfigurable flexgrid optical network with virtualized GMPLS control plane and autonomic controls towards SDN,” in *Proc. SBMO/IEEE MTT-S Int. Microwave Optoelect. Conf. (IMOC)*, Aug. 2013, pp. 1–5.
- [186] Y. Zhao, J. Zhang, H. Yang, and X. Yu, “Data center optical networks (DCON) with OpenFlow based software defined networking (SDN),” in *Proc. CHINACOM*, Aug. 2013, pp. 771–775.
- [187] I. deMiguel *et al.*, “Cognitive dynamic optical networks [invited],” *IEEE/OSA J. Opt. Commun. Netw.*, vol. 5, no. 10, pp. A107–A118, Oct. 2013.
- [188] J. Oliveira *et al.*, “Toward terabit autonomic optical networks based on a software defined adaptive/cognitive approach [invited],” *IEEE/OSA J. Opt. Commun. Netw.*, vol. 7, no. 3, pp. A421–A431, March 2015.
- [189] A. D. Giglio *et al.*, “Cross-layer, dynamic network orchestration, leveraging software-defined optical performance monitors,” in *Proc. IEEE Fotonica AEIT Italian Conf. on Photonics Techn.*, May 2015, pp. 1–4.
- [190] U. Moura *et al.*, “SDN-enabled EDFA gain adjustment cognitive methodology for dynamic optical networks,” in *Proc. IEEE ECOC*, Sep. 2015, pp. 1–3.
- [191] F. Paolucci *et al.*, “Superfilter technique in SDN-controlled elastic optical networks [invited],” *IEEE/OSA J. Opt. Commun. Netw.*, vol. 7, no. 2, pp. A285–A292, 2015.
- [192] H. Carvalho *et al.*, “WSS/EDFA-based optimization strategies for software defined optical networks,” in *Proc. IEEE Microwave and Optoelectronics Conf.*, Nov. 2015, pp. 1–5.
- [193] X. Wang, Y. Fei, M. Razo, A. Fumagalli, and M. Garrich, “Network-wide signal power control strategies in WDM networks,” in *Proc. IEEE Int. Conf. on ONDM*, May 2015, pp. 218–221.
- [194] S. Gringeri, N. Bitar, and T. J. Xia, “Extending software defined network principles to include optical transport,” *IEEE Commun. Mag.*, vol. 51, no. 3, pp. 32–40, 2013.
- [195] M. Jinno, H. Takara, K. Yonenaga, and A. Hirano, “Virtualization in optical networks from network level to hardware level [invited],” *IEEE/OSA J. Opt. Commun. Netw.*, vol. 5, no. 10, pp. A46–A56, 2013.
- [196] G. N. Rouskas, R. Dutta, and I. Baldine, “A new internet architecture to enable software defined optics and evolving optical switching models,” in *Proc. Int. Conf. on Broadband Commun., Networks and Systems (BROADNETS)*, Sep. 2008, pp. 71–76.
- [197] D. Hillerkuss and J. Leuthold, “Software-defined transceivers in dynamic access networks,” *IEEE/OSA J. Lightwave Techn.*, vol. 34, no. 2, pp. 792–797, Jan 2016.
- [198] P. J. Winzer and R.-J. Essiambre, “Advanced optical modulation formats,” *Proc. IEEE*, vol. 94, no. 5, pp. 952–985, 2006.
- [199] A. P. T. Lau *et al.*, “Advanced DSP techniques enabling high spectral efficiency and flexible transmissions,” *IEEE Signal Processing Magazine*, vol. 31, no. 2, pp. 82–92, 2014.
- [200] R. Schmogrow *et al.*, “Real-time software-defined multiformat transmitter generating 64QAM at 28 GBd,” *IEEE Photonics Techn. Letters*, vol. 22, no. 21, pp. 1601–1603, 2010.
- [201] N. Yoshimoto, J.-i. Kani, S.-Y. Kim, N. Iiyama, and J. Terada, “DSP-based optical access approaches for enhancing NG-PON2 systems,” *IEEE Commun. Mag.*, vol. 51, no. 3, pp. 58–64, 2013.
- [202] J. Barton, E. Skogen, M. Mašanović, S. Denbaars, and L. Coldren, “Widely-tunable high-speed transmitters using integrated SGDBRs and Mach-Zehnder modulators,” *IEEE J. Sel. Top. Quantum Electron.*, vol. 9, no. 5, pp. 1113–1117, 2003.
- [203] H. Y. Choi, T. Tsuritani, and I. Morita, “BER-adaptive flexible-format transmitter for elastic optical networks,” *OSA Optics Express*, vol. 20, no. 17, pp. 18 652–18 658, 2012.
- [204] R. Rodes *et al.*, “Carrierless amplitude phase modulation of VCSEL with 4 bits/Hz spectral efficiency for use in WDM-PON,” *OSA Optics Express*, vol. 19, no. 27, pp. 26 551–26 556, 2011.
- [205] N. Bonello, S. Chen, and L. Hanzo, “Low-density parity-check codes and their rateless relatives,” *IEEE Commun. Surv. & Tut.*, vol. 13, no. 1, pp. 3–26, 2011.
- [206] N. Sambo *et al.*, “Control of frequency conversion and defragmentation for super-channels [invited],” *IEEE/OSA J. Opt. Commun. Netw.*, vol. 7, no. 1, pp. A126–A134, Jan 2015.
- [207] M. S. Rasras *et al.*, “Demonstration of a tunable microwave-phonic notch filter using low-loss silicon ring resonators,” *IEEE/OSA J. Lightwave Techn.*, vol. 27, no. 12, pp. 2105–2110, 2009.
- [208] K. Wang *et al.*, “Migration strategies for FTTx solutions based on active optical networks,” *IEEE Commun. Mag.*, vol. 54, no. 2, pp. 78–85, 2016.
- [209] D. Richardson, J. Fini, and L. Nelson, “Space-division multiplexing in optical fibres,” *Nature Photonics*, vol. 7, no. 5, pp. 354–362, 2013.
- [210] J. He *et al.*, “A survey on recent advances in optical communications,” *Computers & Electrical Engineering*, vol. 40, no. 1, pp. 216–240, 2014.
- [211] Y. Wang and X. Cao, “Multi-granular optical switching: A classified overview for the past and future,” *IEEE Commun. Surv. & Tut.*, vol. 14, no. 3, pp. 698–713, 2012.
- [212] Y. Fu *et al.*, “Orion: A hybrid hierarchical control plane of software-defined networking for large-scale networks,” in *Proc. IEEE Int. Conf. on Network Protocols (ICNP)*, 2014, pp. 569–576.
- [213] V. W. Chan, “Optical flow switching networks,” *Proc. IEEE*, vol. 100, no. 5, pp. 1079–1091, 2012.
- [214] J. Schonwalder, M. Bjorklund, and P. Shafer, “Network configuration management using NETCONF and YANG,” *IEEE Commun. Mag.*, vol. 48, no. 9, pp. 166–173, Sept 2010.
- [215] N. Gude *et al.*, “NOX: towards an operating system for networks,” *ACM SIGCOMM Computer Commun. Rev.*, vol. 38, no. 3, pp. 105–110, 2008.
- [216] Y. Zhao, J. Zhang, L. Gao, and H. Yang, “Unified control system for heterogeneous networks with Software Defined Networking (SDN),” in *Proc. Int. ICST Conf. on Commun. and Networking in China (CHINACOM)*, 2013, pp. 781–784.
- [217] D. Dahan, U. Mahlab, A. Teixeira, I. Zacharopoulos, and I. Tomkos, “Optical performance monitoring for translucent/transparent optical networks,” *IET Optoelectronics*, vol. 5, no. 1, pp. 1–18, 2011.
- [218] Q. Sui, A. P. T. Lau, and C. Lu, “OSNR monitoring in the presence of first-order PMD using polarization diversity and DSP,” *IEEE/OSA J. Lightwave Techn.*, vol. 28, no. 15, pp. 2105–2114, 2010.

- [219] J. Schröder *et al.*, “OSNR monitoring of a 1.28 Tbaud signal by interferometry inside a wavelength-selective switch,” *IEEE/OSA J. Lightwave Techn.*, vol. 29, no. 10, pp. 1542–1546, 2011.
- [220] T. Saida *et al.*, “In-band OSNR monitor with high-speed integrated Stokes polarimeter for polarization division multiplexed signal,” *OSA Optics Express*, vol. 20, no. 26, pp. B165–B170, 2012.
- [221] D. R. Zimmerman and L. H. Spiekman, “Amplifiers for the masses: EDFA, EDWA, and SOA amplifiers for metro and access applications,” *IEEE/OSA J. Lightwave Techn.*, vol. 22, no. 1, pp. 63–70, 2004.
- [222] V. Fuentes *et al.*, “Integrating complex legacy systems under OpenFlow control: The DOCSIS use case,” in *Proc. IEEE Europ. Works. on SDN (EWSN)*, Sept 2014, pp. 37–42.
- [223] Y. Luo, “Activities, drivers, and benefits of extending PON over other media,” in *Proc. OSA NFOEC*, 2013, pp. NTu3J–1.
- [224] X. Yu *et al.*, “Spectrum defragmentation implementation based on software defined networking (SDN) in flexi-grid optical networks,” in *Proc. ICNC*, Feb. 2014, pp. 502–505.
- [225] C. Chen *et al.*, “Demonstrations of efficient online spectrum defragmentation in software-defined elastic optical networks,” *IEEE/OSA J. Lightwave Techn.*, vol. 32, no. 24, pp. 4701–4711, Dec 2014.
- [226] P. N. Ji *et al.*, “Demonstration of openflow-enabled traffic and network adaptive transport SDN,” in *Proc. IEEE Int. Conf. OFC*, Mar. 2014, pp. 1–3.
- [227] S. Das, G. Parulkar, and N. McKeown, “Simple unified control for packet and circuit networks,” in *IEEE Photonics Society Summer Topical on Future Global Networks*, Jul. 2009, pp. 1–2.
- [228] Open Networking Foundation, “Addendum to OpenFlow Protocol Specification (v1.0) - Circuit Switch Addendum v0.3,” Palo Alto, CA, USA, Jun. 2010.
- [229] M. Channegowda *et al.*, “Experimental demonstration of an OpenFlow based software-defined optical network employing packet, fixed and flexible DWDM grid technologies on an international multi-domain testbed,” *OSA Optics Express*, vol. 21, no. 5, pp. 5487–5498, Mar. 2013.
- [230] S. Baik, C. Hwang, and Y. Lee, “SDN-based architecture for end-to-end path provisioning in the mixed circuit and packet network environment,” in *Proc. IEEE Asia-Pacific Network Operations and Management Symp.*, Sep. 2014, pp. 1–4.
- [231] X. Cao *et al.*, “Dynamic Openflow-controlled optical packet switching network,” *IEEE/OSA J. Lightwave Techn.*, vol. 33, no. 8, pp. 1500–1507, April 2015.
- [232] H. Harai, H. Furukawa, K. Fujikawa, T. Miyazawa, and N. Wada, “Optical packet and circuit integrated networks and software defined networking extension,” *IEEE/OSA J. Lightwave Techn.*, vol. 32, no. 16, pp. 2751–2759, Aug 2014.
- [233] R. Alvizu and G. Maier, “Can open flow make transport networks smarter and dynamic? an overview on transport SDN,” in *Proc. IEEE Int. Conf. on SaCoNeT*, Jun. 2014, pp. 1–6.
- [234] L. Liu, T. Tsuritani, I. Morita, H. Guo, and J. Wu, “OpenFlow-based wavelength path control in transparent optical networks: A proof-of-concept demonstration,” in *Proc. Eu. Conf. and Exhibition on Optical Commun. (ECOC)*, Sep. 2011, pp. 1–3.
- [235] —, “Experimental validation and performance evaluation of OpenFlow-based wavelength path control in transparent optical networks,” *Opt. Express*, vol. 19, no. 27, pp. 26 578–26 593, Dec. 2011.
- [236] L. Liu *et al.*, “Experimental demonstration of an OpenFlow/PCE integrated control plane for IP over translucent WSON with the assistance of a per-request-based dynamic topology server,” in *Proc. Eu. Conf. and Exhibition on Optical Commun. (ECOC)*, 2012, p. Tu.1.D.3.
- [237] —, “First field trial of an OpenFlow-based unified control plane for multi-layer multi-granularity optical networks,” in *Proc. OFC*, 2012, p. PDP5D.2.
- [238] R. Clegg *et al.*, “Pushing software defined networking to the access,” in *Proc. Eu. Workshop on Softw. Def. Netw. (EWSN)*, Sep. 2014, pp. 31–36.
- [239] H. Khalili, D. Rincón, and S. Sallent, “Towards an integrated SDN-NFV architecture for EPON networks,” in *Advances in Communication Networking*, ser. Lecture Notes in Computer Science, Vol. 8846, Y. Kerमारrec, Ed. Springer Int. Publishing, 2014, pp. 74–84.
- [240] Y. Lee and Y. Kim, “A design of 10 Gigabit capable passive optical network (XG-PON1) architecture based on Software Defined Network (SDN),” in *Proc. Int. Conf. on IEEE Information Networking (ICOIN)*, 2015, pp. 402–404.
- [241] P. Parol and M. Pawłowski, “Towards networks of the future: SDN paradigm introduction to PON networking for business applications,” in *Proc. Federated Conf. on Computer Science and Info. Sys. (FedCSIS)*, Sep. 2013, pp. 829–836.
- [242] P. Parol and M. Pawłowski, “Future proof access networks for B2B applications,” *Informatica*, vol. 38, no. 3, pp. 193–204, 2014.
- [243] B. Yan, J. Zhou, J. Wu, and Y. Zhao, “Poster: SDN based energy management system for optical access network,” in *Proc. CHINACOM*, Aug. 2014, pp. 658–659.
- [244] K. Kanonakis, N. Cvijetic, I. Tomkos, and T. Wang, “Dynamic software-defined resource optimization in next-generation optical access enabled by OFDMA-based meta-MAC provisioning,” *IEEE/OSA J. Lightwave Techn.*, vol. 31, no. 14, pp. 2296–2306, Jul. 2013.
- [245] R. Muñoz, R. Casellas, R. Vilalta, and R. Martínez, “Dynamic and adaptive control plane solutions for flexi-grid optical networks based on stateful PCE,” *IEEE/OSA J. Lightwave Techn.*, vol. 32, no. 16, pp. 2703–2715, Aug 2014.
- [246] Z. Zhu *et al.*, “OpenFlow-assisted online defragmentation in single-/multi-domain software-defined elastic optical networks [invited],” *IEEE/OSA J. Opt. Commun. Netw.*, vol. 7, no. 1, pp. A7–A15, Jan 2015.
- [247] G. Meloni *et al.*, “Software-defined defragmentation in space-division multiplexing with quasi-hitless fast core switching,” *IEEE/OSA J. Lightwave Techn.*, vol. 34, no. 8, pp. 1956–1962, April 2016.
- [248] J. Wu, Y. Zhao, J. Zhang, J. Zhou, and J. Sun, “Global dynamic bandwidth optimization for software defined optical access and aggregation networks,” in *Proc. IEEE Int. Conf. on Optical Commun. and Networks (ICOON)*, 2014, pp. 1–4.
- [249] Y. Zhao, B. Yan, J. Wu, and J. Zhang, “Software-defined dynamic bandwidth optimization (SD-DBO) algorithm for optical access and aggregation networks,” *Photonic Netw. Commun.*, vol. 31, no. 2, pp. 251–258, Apr. 2016.
- [250] D. Bojic *et al.*, “Advanced wireless and optical technologies for small-cell mobile backhaul with dynamic software-defined management,” *IEEE Commun. Mag.*, vol. 51, no. 9, pp. 86–93, 2013.
- [251] A. Tanaka and N. Cvijetic, “Software defined flexible optical access networks enabling throughput optimization and OFDM-based dynamic service provisioning for future mobile backhaul,” *IEICE Trans. Commun.*, vol. E97.B, no. 7, pp. 1244–1251, 2014.
- [252] J. Costa-Requena, J. L. Santos, and V. F. Guasch, “Mobile backhaul transport streamlined through SDN,” in *Proc. IEEE ICTON*, Jul. 2015, pp. 1–4.
- [253] F. Slyne and M. Ruffini, “An SDN-driven approach to a flat Layer-2 telecommunications network,” in *Proc. Int. Conf. on Transparent Optical Networks (ICTON)*, Jul. 2014, pp. 1–4.
- [254] U. Mandal *et al.*, “Heterogeneous bandwidth provisioning for virtual machine migration over SDN-enabled optical networks,” in *Proc. OFC*, Mar. 2014, pp. 1–3.
- [255] J. Wang, N. Cvijetic, K. Kanonakis, T. Wang, and G.-K. Chang, “Novel optical access network virtualization and dynamic resource allocation algorithms for the internet of things,” in *Proc. OSA OFC*, 2015, pp. Tu2E–3.
- [256] L. Liu *et al.*, “Interworking between OpenFlow and PCE for dynamic wavelength path control in multi-domain WSON,” in *Proc. OFC/NFOEC*, Mar. 2012, pp. 1–3.
- [257] R. Casellas *et al.*, “Control and management of flexi-grid optical networks with an integrated stateful path computation element and OpenFlow controller [invited],” *IEEE/OSA J. Opt. Commun. Netw.*, vol. 5, no. 10, pp. A57–A65, Oct 2013.
- [258] L. Liu, T. Tsuritani, and I. Morita, “From GMPLS to PCE/GMPLS to OpenFlow: How much benefit can we get from the technical evolution of control plane in optical networks?” in *Proc. Int. Conf. on Transparent Optical Netw. (ICTON)*, Jul. 2012, pp. 1–4.
- [259] Y. Zhao, J. Zhang, H. Yang, and Y. Yu, “Which is more suitable for the control over large scale optical networks, GMPLS or OpenFlow?” in *Proc. OFC/NFOEC*, Mar. 2013, pp. 1–3.
- [260] N. Cvijetic, M. Angelou, A. Patel, P. Ji, and T. Wang, “Defining optical software-defined networks (SDN): From a compilation of demos to network model synthesis,” in *Proc. OFC/NFOEC*, Mar. 2013, pp. 1–3.
- [261] R. Veisllari, N. Stol, S. Bjornstad, and C. Raffaelli, “Scalability analysis of SDN-controlled optical ring MAN with hybrid traffic,” in *Proc. IEEE ICC*, Jun. 2014, pp. 3283–3288.
- [262] R. Sánchez, J. A. Hernández, and D. Larrabeiti, “Using transparent WDM metro rings to provide an out-of-band control network for openflow in MAN,” in *Proc. IEEE ICTON*, Jun. 2013, pp. 1–4.
- [263] M. C. Penna, E. Jamhour, and M. L. F. Miguel, “A clustered SDN architecture for large scale WSON,” in *Proc. IEEE Advanced Information Net. and Applications*, May 2014, pp. 374–381.
- [264] J. Shin *et al.*, “Transport SDN: Trends, standardization and architecture,” in *Proc. IEEE Int. Conf. on Information and Commun. Techn. Convergence*, Oct. 2014, pp. 138–139.

- [265] R. Muñoz, R. Casellas, R. Martínez, and R. Vilalta, "PCE: What is it, how does it work and what are its limitations?" *IEEE/OSA J. Lightwave Techn.*, vol. 32, no. 4, pp. 528–543, 2014.
- [266] E. Oki *et al.*, "Dynamic multilayer routing schemes in GMPLS-based IP+ optical networks," *IEEE Commun. Mag.*, vol. 43, no. 1, pp. 108–114, 2005.
- [267] F. Paolucci, F. Cugini, A. Giorgetti, N. Sambo, and P. Castoldi, "A survey on the path computation element (PCE) architecture," *IEEE Commun. Surv. & Tut.*, vol. 15, no. 4, pp. 1819–1841, 2013.
- [268] R. Casellas, R. Muñoz, R. Martínez, and R. Vilalta, "Applications and status of path computation elements [invited]," *IEEE/OSA J. Opt. Commun. Netw.*, vol. 5, no. 10, pp. A192–A203, Oct 2013.
- [269] W. Wei *et al.*, "PONIARD: a programmable optical networking infrastructure for advanced research and development of future internet," *IEEE/OSA J. Lightwave Techn.*, vol. 27, no. 3, pp. 233–242, 2009.
- [270] W. Wei, J. Hu, C. Wang, T. Wang, and C. Qiao, "A programmable router interface supporting link virtualization with adaptive optical OFDMA transmission," in *Proc. OSA OFC*, 2009, pp. JWA68, 1–3.
- [271] W. Wei, C. Wang, and X. Liu, "Adaptive IP/optical OFDM networking design," in *Proc. OSA OFC*, 2010, pp. OWR6, 1–3.
- [272] M. Jinno and Y. Tsukishima, "Virtualized optical network (VON) for agile cloud computing environment," in *Proc. OSA OFC*, 2009, p. OMG1.
- [273] L. Zhou, G. Peng, and N. Chand, "Demonstration of a novel software-defined Flex PON," *Photonic Netw. Commun.*, vol. 29, no. 3, pp. 282–290, Jun. 2015.
- [274] Q. Dai, J. Zou, G. Shou, Y. Hu, and Z. Guo, "Network virtualization based seamless networking scheme for fiber-wireless (FiWi) networks," *Commun., China*, vol. 11, no. 5, pp. 1–16, 2014.
- [275] Q. Dai, G. Shou, Y. Hu, and Z. Guo, "A general model for hybrid fiber-wireless (FiWi) access network virtualization," in *Proc. IEEE Int. Conf. on Commun. Workshops (ICC)*, Jun. 2013, pp. 858–862.
- [276] S. He, G. Shou, Y. Hu, and Z. Guo, "Performance of multipath in fiber-wireless (FiWi) access network with network virtualization," in *Proc. IEEE Military Commun. Conf. (MILCOM)*, Nov. 2013, pp. 928–932.
- [277] —, "Intelligent multipath access in fiber-wireless (FiWi) network with network virtualization," in *Proc. OSA Asia Commun. and Photonics Conf.*, 2013, pp. AF2G–38.
- [278] X. Meng, G. Shou, Y. Hu, and Z. Guo, "Efficient load balancing multipath algorithm for fiber-wireless network virtualization," in *Proc. IET Int. Conf. on Information and Commun. Techn. (ICT)*, 2014, pp. 1–6.
- [279] Q.-I. Dai, G.-C. Shou, Y.-h. Hu, and Z.-G. Guo, "Performance improvement for applying network virtualization in fiber-wireless (FiWi) access networks," *J. Zhejiang Univ. SCIENCE C*, vol. 15, no. 11, pp. 1058–1070, 2014.
- [280] A. R. Dhaini, P.-H. Ho, and X. Jiang, "WiMAX-VPON: A framework of layer-2 VPNs for next-generation access networks," *IEEE/OSA J. Opt. Commun. Netw.*, vol. 2, no. 7, pp. 400–414, 2010.
- [281] A. Dhaini, P.-H. Ho, and X. Jiang, "Performance analysis of QoS-aware layer-2 VPNs over fiber-wireless (FiWi) networks," in *Proc. IEEE Global Telecommunications Conf. (GLOBECOM)*, Dec. 2010, pp. 1–6.
- [282] W. Miao *et al.*, "SDN-enabled OPS with QoS guarantee for reconfigurable virtual data center networks," *IEEE/OSA J. Opt. Commun. Netw.*, vol. 7, no. 7, pp. 634–643, 2015.
- [283] S. Peng *et al.*, "Multi-tenant software-defined hybrid optical switched data centre," *IEEE/OSA J. Lightwave Techn.*, vol. 33, no. 15, pp. 3224–3233, 2015.
- [284] A. Pagès *et al.*, "Optimal virtual slice composition toward multi-tenancy over hybrid OCS/OPS data center networks," *IEEE/OSA J. Opt. Commun. Netw.*, vol. 7, no. 10, pp. 974–986, 2015.
- [285] G. M. Saridis *et al.*, "Lightness: A function-virtualizable software defined data center network with all-optical circuit/packet switching," *IEEE/OSA J. Lightwave Techn.*, vol. 34, no. 7, pp. 1618–1627, April 2016.
- [286] B. Kantarci and H. T. Mouftah, "Resilient design of a cloud system over an optical backbone," *IEEE Network*, vol. 29, no. 4, pp. 80–87, 2015.
- [287] J. Ahmed, P. Monti, L. Wosinska, and S. Spadaro, "Enhancing restoration performance using service relocation in PCE-based resilient optical clouds," in *Proc. OSA OFC*, 2014, pp. Th3B–3.
- [288] R. Doverspike *et al.*, "Using SDN technology to enable cost-effective bandwidth-on-demand for cloud services [invited]," *IEEE/OSA J. Opt. Commun. Netw.*, vol. 7, no. 2, pp. A326–A334, 2015.
- [289] W. Xie, J. Zhu, C. Huang, M. Luo, and W. Chou, "Dynamic resource pooling and trading mechanism in flexible-grid optical network virtualization," in *IEEE Int. Conf. on Cloud Networking (CloudNet)*, 2014, pp. 167–172.
- [290] L. Velasco, A. Asensio, J. Berral, A. Castro, and V. López, "Towards a carrier SDN: an example for elastic inter-datacenter connectivity," *OSA Optics Express*, vol. 22, no. 1, pp. 55–61, 2014.
- [291] L. Zhang, T. Han, and N. Ansari, "Renewable energy-aware inter-datacenter virtual machine migration over elastic optical networks," *arXiv preprint arXiv:1508.05400*, 2015.
- [292] A. Tzanakaki *et al.*, "A converged network architecture for energy efficient mobile cloud computing," in *Proc. IEEE Int. Conf. on Optical Network Design and Modeling*, 2014, pp. 120–125.
- [293] S. Peng, R. Nejabati, S. Azodolmolky, E. Escalona, and D. Simeonidou, "An impairment-aware virtual optical network composition mechanism for future Internet," *OSA Optics Express*, vol. 19, no. 26, pp. B251–B259, 2011.
- [294] S. Peng, R. Nejabati, and D. Simeonidou, "Impairment-aware optical network virtualization in single-line-rate and mixed-line-rate WDM networks," *IEEE/OSA J. Opt. Commun. Netw.*, vol. 5, no. 4, pp. 283–293, Apr. 2013.
- [295] S. Zhang, L. Shi, C. S. Vadrevu, and B. Mukherjee, "Network virtualization over WDM and flexible-grid optical networks," *Opt. Sw. Netw.*, vol. 10, no. 4, pp. 291–300, 2013.
- [296] J. Zhao, S. Subramaniam, and M. Brandt-Pearce, "Virtual topology mapping in elastic optical networks," in *Proc. IEEE ICC*, 2013, pp. 3904–3908.
- [297] L. Gong and Z. Zhu, "Virtual optical network embedding (VONE) over elastic optical networks," *IEEE/OSA J. Lightwave Techn.*, vol. 32, no. 3, pp. 450–460, 2014.
- [298] X. Wang, Q. Zhang, I. Kim, P. Palacharla, and M. Sekiya, "Virtual network provisioning over distance-adaptive flexible-grid optical networks [invited]," *IEEE/OSA J. Opt. Commun. Netw.*, vol. 7, no. 2, pp. A318–A325, 2015.
- [299] Q. Hu, Y. Wang, and X. Cao, "Survivable network virtualization for single facility node failure: A network flow perspective," *Opt. Sw. Netw.*, vol. 10, no. 4, pp. 406–415, 2013.
- [300] Z. Ye, A. N. Patel, P. N. Ji, and C. Qiao, "Survivable virtual infrastructure mapping with dedicated protection in transport software-defined networks [invited]," *IEEE/OSA J. Opt. Commun. Netw.*, vol. 7, no. 2, pp. A183–A189, 2015.
- [301] W. Xie *et al.*, "Survivable impairment-constrained virtual optical network mapping in flexible-grid optical networks," *IEEE/OSA J. Opt. Commun. Netw.*, vol. 6, no. 11, pp. 1008–1017, 2014.
- [302] H. Jiang, Y. Wang, L. Gong, and Z. Zhu, "Availability-aware survivable virtual network embedding in optical datacenter networks," *IEEE/OSA J. Opt. Commun. Netw.*, vol. 7, no. 12, pp. 1160–1171, 2015.
- [303] S. Hong *et al.*, "Survivable virtual topology design in IP over WDM multi-domain networks," in *Proc. IEEE ICC*, Jun. 2015, pp. 5150–5155.
- [304] Z. Ye *et al.*, "Upgrade-aware virtual infrastructure mapping in software-defined elastic optical networks," *Photonic Netw. Commun.*, vol. 28, no. 1, pp. 34–44, 2014.
- [305] J. Zhang *et al.*, "Dynamic virtual network embedding over multilayer optical networks," *IEEE/OSA J. Opt. Commun. Netw.*, vol. 7, no. 9, pp. 918–927, 2015.
- [306] L. Nonde, T. E. El-Gorashi, and J. M. Elmoghani, "Energy efficient virtual network embedding for cloud networks," *IEEE/OSA J. Lightwave Techn.*, vol. 33, no. 9, pp. 1828–1849, 2015.
- [307] B. Chen, "Power-aware virtual optical network provisioning in flexible bandwidth optical networks [invited]," *Photonic Netw. Commun., in print*, pp. 1–10, 2016.
- [308] G. Shen, Y. Lui, and S. K. Bose, "'Follow the Sun, Follow the Wind' lighthouse virtual topology reconfiguration in IP Over WDM network," *IEEE/OSA J. Lightwave Techn.*, vol. 32, no. 11, pp. 2094–2105, 2014.
- [309] H. Wang and G. N. Rouskas, "Hierarchical traffic grooming: A tutorial," *Computer Networks*, vol. 69, pp. 147–156, 2014.
- [310] M. A. deSiqueira, F. N. C. vantHooft, J. R. F. deOliveira, E. R. M. Madeira, and C. E. Rothenberg, "Providing optical network as a service with policy-based transport sdn," *J. Network and Systems Management*, vol. 23, no. 2, pp. 360–373, 2015.
- [311] L. Liu *et al.*, "OpenSlice: an OpenFlow-based control plane for spectrum sliced elastic optical path networks," *Opt. Express*, vol. 21, no. 4, pp. 4194–4204, Feb. 2013.
- [312] S. Azodolmolky *et al.*, "Optical FlowVisor: an OpenFlow-based optical network virtualization approach," in *Proc. NFOEC*, 2012, p. JTh2A.41.

- [313] C. Bock *et al.*, "Techno-economics and performance of convergent radio and fibre architectures," in *Transparent Optical Networks (ICTON), 2014 16th Int. Conf. on*, July 2014, pp. 1–4.
- [314] X. Liu and F. Effenberger, "Trends in PON - fiber/wireless convergence and software-defined transmission and networking," in *Proc. IEEE OECC*, June 2015, pp. 1–3.
- [315] Y. Chen, K. Wu, and Q. Zhang, "From QoS to QoE: A survey and tutorial on state of art, evolution and future directions of video quality analysis," *IEEE Commun. Surv. & Tut.*, vol. 17, no. 2, pp. 1126–1165, 2015.
- [316] M. Seufert, S. Egger, T. Zinner, T. Hobfeld, and P. Tran-Gia, "A survey on quality of experience of HTTP adaptive streaming," *IEEE Commun. Surv. & Tut.*, vol. 17, no. 1, pp. 469–492, 2015.
- [317] S. Azodolmolky, P. Wieder, and R. Yahyapour, "SDN-based cloud computing networking," in *Proc. IEEE Int. Conf. on Transparent Optical Networks (ICTON)*, 2013, pp. 1–4.
- [318] M. Banikazemi, D. Olshefski, A. Shaikh, J. Tracey, and G. Wang, "Meridian: an SDN platform for cloud network services," *IEEE Commun. Mag.*, vol. 51, no. 2, pp. 120–127, 2013.
- [319] M. F. Bari *et al.*, "Data center network virtualization: A survey," *IEEE Commun. Surv. & Tut.*, vol. 15, no. 2, pp. 909–928, 2013.
- [320] N. Fernando, S. W. Loke, and W. Rahayu, "Mobile cloud computing: A survey," *Future Generation Computer Systems*, vol. 29, no. 1, pp. 84–106, 2013.
- [321] T. Wood, K. Ramakrishnan, P. Shenoy, and J. Van derMerwe, "Cloud-Net: dynamic pooling of cloud resources by live WAN migration of virtual machines," *ACM SIGPLAN Notices*, vol. 46, no. 7, pp. 121–132, Jul. 2011.
- [322] T. Wood, K. Ramakrishnan, J. Van Der Merwe, and P. Shenoy, "Cloud-Net: A platform for optimized WAN migration of virtual machines," Univ. of Massachusetts Technical Report TR-2010-002, Tech. Rep., 2010.
- [323] S. Peng, R. Nejabati, and D. Simeonidou, "Role of optical network virtualization in cloud computing [invited]," *IEEE/OSA J. Opt. Commun. Netw.*, vol. 5, no. 10, pp. A162–A170, Oct. 2013.
- [324] R. Dutta and G. N. Rouskas, "A survey of virtual topology design algorithms for wavelength routed optical networks," *Optical Networks Magazine*, vol. 1, no. 1, pp. 73–89, 2000.
- [325] M. R. Rahman and R. Boutaba, "SVNE: Survivable virtual network embedding algorithms for network virtualization," *IEEE Trans. Network and Service Management*, vol. 10, no. 2, pp. 105–118, 2013.
- [326] A. Nag, M. Tornatore, and B. Mukherjee, "Optical network design with mixed line rates and multiple modulation formats," *IEEE/OSA J. Lightwave Techn.*, vol. 28, no. 4, pp. 466–475, 2010.
- [327] S. Azodolmolky *et al.*, "A survey on physical layer impairments aware routing and wavelength assignment algorithms in optical networks," *Computer Networks*, vol. 53, no. 7, pp. 926–944, 2009.
- [328] C. V. Saradhi and S. Subramaniam, "Physical layer impairment aware routing (PLIAR) in WDM optical networks: issues and challenges," *IEEE Commun. Surv. & Tut.*, vol. 11, no. 4, pp. 109–130, 2009.
- [329] H. Zhu, H. Zang, K. Zhu, and B. Mukherjee, "A novel generic graph model for traffic grooming in heterogeneous WDM mesh networks," *IEEE/ACM Trans. Networking*, vol. 11, no. 2, pp. 285–299, 2003.
- [330] A. P. Bianzino, C. Chaudet, D. Rossi, and J. Rougier, "A survey of green networking research," *IEEE Commun. Surv. & Tut.*, vol. 14, no. 1, pp. 3–20, 2012.
- [331] J. Zhang *et al.*, "Energy-efficient traffic grooming in sliceable-transponder-equipped IP-over-elastic optical networks [invited]," *IEEE/OSA J. Opt. Commun. Netw.*, vol. 7, no. 1, pp. A142–A152, 2015.
- [332] M. Jinno *et al.*, "Spectrum-efficient and scalable elastic optical path network: architecture, benefits, and enabling technologies," *IEEE Commun. Mag.*, vol. 47, no. 11, pp. 66–73, 2009.
- [333] A. Ahmed and A. Shami, "RPR–EPON–WiMAX hybrid network: A solution for access and metro networks," *IEEE/OSA J. Opt. Commun. Netw.*, vol. 4, no. 3, pp. 173–188, 2012.
- [334] J. Segarra, V. Sales, and J. Prat, "An all-optical access–metro interface for hybrid WDM/TDM PON based on obs," *IEEE/OSA J. Lightwave Techn.*, vol. 25, no. 4, pp. 1002–1016, 2007.
- [335] L. Valcarenghi *et al.*, "Experimenting the integration of green optical access and metro networks based on SDN," in *Proc. IEEE Int. Conf. on Transparent Optical Networks (ICTON)*, 2015, pp. 1–4.
- [336] H. Woesner and D. Fritzsche, "SDN and OpenFlow for converged access/aggregation networks," in *Proc. OFC/NFOEC*, vol. 2013, 2013, pp. 1–3.
- [337] A. Manzalini, R. Minerva, F. Callegati, W. Cerroni, and A. Campi, "Clouds of virtual machines in edge networks," *IEEE Commun. Mag.*, vol. 51, no. 7, pp. 63–70, 2013.
- [338] H. T. Dinh, C. Lee, D. Niyato, and P. Wang, "A survey of mobile cloud computing: architecture, applications, and approaches," *Wireless Commun. and Mobile Computing*, vol. 13, no. 18, pp. 1587–1611, 2013.
- [339] M. Satyanarayanan, P. Bahl, R. Caceres, and N. Davies, "The case for vm-based cloudlets in mobile computing," *IEEE Pervasive Computing*, vol. 8, no. 4, pp. 14–23, 2009.
- [340] G. Schaffrath, S. Schmid, and A. Feldmann, "Optimizing long-lived cloudlets with migrations," in *Proc. IEEE/ACM Int. Conf. on Utility and Cloud Computing*, 2012, pp. 99–106.
- [341] T. Verbelen, P. Simoens, F. De Turck, and B. Dhoedt, "Cloudlets: bringing the cloud to the mobile user," in *Proc. ACM Workshop on Mobile Cloud Computing and Services*, 2012, pp. 29–36.
- [342] M. Maier and B. P. Rimal, "Invited paper: The audacity of fiber-wireless (FiWi) networks: revisited for clouds and cloudlets," *IEEE Commun., China*, vol. 12, no. 8, pp. 33–45, Aug. 2015.
- [343] Y. Zhao *et al.*, "Time-aware software defined networking (Ta-SDN) for flexi-grid optical networks supporting data center application," in *Proc. IEEE Globecom Workshops (GC Wkshps)*, Dec. 2013, pp. 1221–1226.
- [344] K. Li *et al.*, "QoE-based bandwidth allocation with SDN in FTTH networks," in *Proc. IEEE Int. Conf. NOMS*, May 2014, pp. 1–8.
- [345] A. N. Patel, P. N. Ji, and T. Wang, "QoS-aware optical burst switching in OpenFlow based software-defined optical networks," in *Proc. IEEE Conf. on ONDM*, Apr. 2013, pp. 275–280.
- [346] P. Wette and H. Karl, "On the quality of selfish virtual topology reconfiguration in IP-over-WDM networks," in *Proc. IEEE Wksp. LANMAN*, Apr. 2013, pp. 1–6.
- [347] S. Tariq and M. Bassiouni, "QAMO-SDN: QoS aware multipath TCP for software defined optical networks," in *Proc. IEEE CCNC*, Jan. 2015, pp. 485–491.
- [348] A. Scambelluri, F. Paolucci, F. Cugini, L. Valcarenghi, and P. Castoldi, "Generalized SDN control for access/metro/core integration in the framework of the interface to the routing system (I2RS)," in *Proc. IEEE Globecom Workshops (GC Wkshps)*, Dec. 2013, pp. 1216–1220.
- [349] I. Ilchmann, L. Dembeck, and J. Milbrandt, "A Transport-SDN application for incremental on-line network optimization," in *Proc. IEEE Int. Conf. on Photonic Netw.s*, May 2015, pp. 1–4.
- [350] X. Chang *et al.*, "Software defined backpressure mechanism for edge router," in *Proc. IEEE Int. Symp. on Quality of Service*, Jun. 2015, pp. 171–176.
- [351] J. Rükert, R. Bifulco, M. Rizwan-Ul-Haq, H.-J. Kolbe, and D. Hausheer, "Flexible traffic management in broadband access networks using Software Defined Networking," in *Proc. IEEE Network Operations and Management Symp. (NOMS)*, May 2014, pp. 1–8.
- [352] E. Tego, F. Matera, V. Attanasio, and D. Del Buono, "Quality of service management based on Software Defined Networking approach in wide GbE networks," in *Proc. Euro Med Telco Conf. (EMTC)*, Nov. 2014, pp. 1–5.
- [353] D. Chitimala *et al.*, "Application-aware software-defined EPON access network," *Photonic Netw. Commun.*, vol. 30, no. 3, pp. 324–336, 2015.
- [354] —, "Application-aware software-defined EPON upstream resource allocation," in *Proc. IEEE Int. Conf. OFC*, Mar. 2015, pp. 1–3.
- [355] X. Li *et al.*, "Joint bandwidth provisioning and cache management for video distribution in software-defined passive optical networks," in *Proc. IEEE OFC*, March 2014, pp. 1–3.
- [356] J. Matias, J. Garay, A. Mendiola, N. Toledo, and E. Jacob, "FlowNAC: Flow-based network access control," in *Proc. Eu. Workshop on Software Defined Netw. (EWSDN)*, Sep. 2014, pp. 79–84.
- [357] A. K. Nayak, A. Reimers, N. Feamster, and R. Clark, "Resonance: dynamic access control for enterprise networks," in *Proc. of ACM Workshop on Research on Enterprise Netw.*, 2009, pp. 11–18.
- [358] Y. Li, N. Hua, Y. Song, S. Li, and X. Zheng, "Fast lightpath hopping enabled by time synchronization for optical network security," *IEEE Commun. Letters*, vol. 20, no. 1, pp. 101–104, Jan 2016.
- [359] H. Zhu, H. Fan, X. Luo, and Y. Jin, "Intelligent timeout master: Dynamic timeout for sdn-based data centers," in *Proc. IEEE Int. Symp. Integrated Net. Manag.*, May 2015, pp. 734–737.
- [360] Y. Ji *et al.*, "All optical switching networks with energy-efficient technologies from components level to network level," *IEEE Journ. on Selected Areas in Commun.*, vol. 32, no. 8, pp. 1600–1614, Aug 2014.
- [361] H. Yang *et al.*, "Multi-stratum resource integration for OpenFlow-based data center interconnect [invited]," *IEEE/OSA J. Opt. Commun. Netw.*, vol. 5, no. 10, pp. A240–A248, 2013.

- [362] E. Tego, F. Matera, and D. D. Buono, "Software defined networking experimental approach for energy saving in GbE networks," in *Fotonica AET Italian Conf. on Photonics Techn.*, May 2014, pp. 1–4.
- [363] J. Wang, Y. Yan, and L. Dittmann, "Design of energy efficient optical networks with software enabled integrated control plane," *IET Networks*, vol. 4, no. 1, pp. 30–36, 2015.
- [364] O. Yevsieieva and Y. Ilyashenko, "Multipath routing as a tool for energy saving in transport software defined network," in *Proc. IEEE Int. Scientific-Practical Conf. on PICST*, Oct. 2015, pp. 25–28.
- [365] M. S. Yoon and A. E. Kamal, "Power minimization in fat-tree SDN datacenter operation," in *Proc. IEEE GLOBECOM*, Dec. 2015, pp. 1–7.
- [366] S. S. Savas, C. Ma, M. Tornatore, and B. Mukherjee, "Backup provisioning with partial protection for disaster-survivable software-defined optical networks," *Photonic Netw. Commun.*, vol. 31, no. 2, pp. 186–195, 2016.
- [367] A. Giorgetti, F. Paolucci, F. Cugini, and P. Castoldi, "Dynamic restoration with GMPLS and SDN control plane in elastic optical networks," *IEEE/OSA J. Opt. Commun. Netw.*, vol. 7, no. 2, pp. A174–A182, February 2015.
- [368] A. Aguado *et al.*, "Dynamic virtual network reconfiguration over SDN orchestrated multitechnology optical transport domains," *IEEE/OSA J. Lightwave Techn.*, vol. 34, no. 8, pp. 1933–1938, April 2016.
- [369] F. Slyne, N. Kituswan, S. McGettrick, D. Payne, and M. Ruffini, "Design and experimental test of 1:1 end-to-end protection for LR-PON using an SDN multi-tier control plane," in *Proc. Eu. Conf. on Optical Commun. (ECOC)*, Sep. 2014, pp. 1–3.
- [370] Y.-J. Kim, J. E. Simsarian, and M. Thottan, "Cross-layer orchestration for elastic and resilient packet service in a reconfigurable optical transport network," in *Proc. IEEE Conf.*, Mar. 2015, pp. 1–3.
- [371] D. Zhang *et al.*, "Highly survivable software defined synergistic IP+optical transport networks," in *Proc. IEEE Int. Conf. OFC*, Mar. 2014, pp. 1–3.
- [372] H. Rastegarfar and D. C. Kilper, "Robust software-defined optical networking for the power grid," in *Proc. IEEE ICNC*, Feb. 2016, pp. 1–5.
- [373] C. DeCusatis, "Optical interconnect networks for data communications," *IEEE/OSA J. Lightwave Techn.*, vol. 32, no. 4, pp. 544–552, Feb 2014.
- [374] T. Dietz *et al.*, "Enhancing the BRAS through virtualization," in *Proc. IEEE Conf. NetSoft*, April 2015, pp. 1–5.
- [375] "I2RS Status IETF," 2016. [Online]. Available: <http://tools.ietf.org/wg/i2rs/>
- [376] S. Hares and R. White, "Software-defined networks and the interface to the routing system (I2RS)," *IEEE Internet Computing*, no. 4, pp. 84–88, 2013.
- [377] B. Ahlgren, C. Dannewitz, C. Imbrenda, D. Kutscher, and B. Ohlman, "A survey of information-centric networking," *IEEE Commun. Mag.*, vol. 50, no. 7, pp. 26–36, July 2012.
- [378] J. Choi, A. S. Reaz, and B. Mukherjee, "A survey of user behavior in VoD service and bandwidth-saving multicast streaming schemes," *IEEE Commun. Surv. & Tut.*, vol. 14, no. 1, pp. 156–169, First 2012.
- [379] M. Casado *et al.*, "Ethane: Taking control of the enterprise," *ACM SIGCOMM Computer Commun. Rev.*, vol. 37, no. 4, pp. 1–12, 2007.
- [380] H. Shuangyu, L. Jianwei, M. Jian, and C. Jie, "Hierarchical solution for access control and authentication in software defined networks," in *Proc. Network and System Security, Springer Lecture Notes in Computer Science, Vol. 8792*, vol. 8792, 2014, pp. 70–81.
- [381] K. Pagiamtzis and A. Sheikholeslami, "Content-addressable memory (CAM) circuits and architectures: A tutorial and survey," *IEEE J. Solid-State Cir.*, vol. 41, no. 3, pp. 712–727, March 2006.
- [382] P. Bull, R. Austin, and M. Sharma, "Pre-emptive flow installation for internet of things devices within software defined networks," in *Proc. IEEE Int. Conf. on FiCloud*, Aug 2015, pp. 124–130.
- [383] H. Liang, P. Hong, J. Li, and D. Ni, "Effective idletimeout value for instant messaging in software defined networks," in *Proc. IEEE ICCW Wkps*, June 2015, pp. 352–356.
- [384] X. N. Nguyen, D. Saucez, C. Barakat, and T. Turletti, "Rules placement problem in openflow networks: a survey," *IEEE Commun. Surv. & Tut., in print*, 2016.
- [385] L. Xie *et al.*, "An adaptive scheme for data forwarding in software defined network," in *Wireless Communications and Signal Processing (WCSP), 2014 Sixth Int. Conf. on*, Oct 2014, pp. 1–5.
- [386] L. Zhang, S. Wang, S. Xu, R. Lin, and H. Yu, "TimeoutX: An adaptive flow table management method in software defined networks," in *Proc. IEEE GLOBECOM*, Dec 2015, pp. 1–6.
- [387] R. S. Tucker, "Green optical communications Part II: Energy limitations in networks," *IEEE J. Selected Topics in Quantum Electronics*, vol. 17, no. 2, pp. 261–274, 2011.
- [388] Y. Zhang, P. Chowdhury, M. Tornatore, and B. Mukherjee, "Energy efficiency in telecom optical networks," *IEEE Commun. Surv. & Tut.*, vol. 12, no. 4, pp. 441–458, 2010.
- [389] A. V. Lehmen *et al.*, "CORONET: testbeds, demonstration, and lessons learned [invited]," *IEEE/OSA J. Opt. Commun. Netw.*, vol. 7, no. 3, pp. A447–A458, March 2015.
- [390] L. Liu *et al.*, "Dynamic OpenFlow-based lightpath restoration in elastic optical networks on the GENI testbed," *IEEE/OSA J. Lightwave Techn.*, vol. 33, no. 8, pp. 1531–1539, April 2015.
- [391] F. Paolucci, A. Sgambelluri, N. Sambo, F. Cugini, and P. Castoldi, "Hierarchical OAM infrastructure for proactive control of SDN-based elastic optical networks," in *Proc. IEEE GLOBECOM*, Dec. 2015, pp. 1–6.
- [392] M. Parandehgheibi, E. Modiano, and D. Hay, "Mitigating cascading failures in interdependent power grids and communication networks," in *Proc. IEEE Int. Conf. on SmartGridComm*, Nov 2014, pp. 242–247.
- [393] T. Lehman *et al.*, "Multilayer networks: an architecture framework," *IEEE Commun. Mag.*, vol. 49, no. 5, pp. 122–130, May 2011.
- [394] M. Ruiz *et al.*, "Survivable IP/MPLS-over-WSON multilayer network optimization," *IEEE/OSA J. Opt. Commun. Netw.*, vol. 3, no. 8, pp. 629–640, 2011.
- [395] F. Touvet and D. Harle, "Network resilience in multilayer networks: A critical review and open issues," in *Proc. Networking - ICN 2001*. Springer, 2001, pp. 829–837.
- [396] M. Vigoureux *et al.*, "Multilayer traffic engineering for GMPLS-enabled networks," *IEEE Commun. Mag.*, vol. 43, no. 7, pp. 44–50, 2005.
- [397] Y. Yoshida *et al.*, "SDN-based network orchestration of variable-capacity optical packet switching network over programmable flexi-grid elastic optical path network," *IEEE/OSA J. Lightwave Techn.*, vol. 33, no. 3, pp. 609–617, 2015.
- [398] E. Kissel, M. Swany, B. Tierney, and E. Pouyoul, "Efficient wide area data transfer protocols for 100 Gbps networks and beyond," in *Proc. Int. Workshop on Network-Aware Data Management (NDM)*, 2013, pp. 3:1–3:10.
- [399] H. Rodrigues *et al.*, "Traffic optimization in multi-layered WANs using SDN," in *Proc. IEEE Symp. on High-Performance Interconnects (HOTI)*, Aug. 2014, pp. 71–78.
- [400] Y. Iizawa and K. Suzuki, "Multi-layer and multi-domain network orchestration by ODENOS," in *Proc. OSA OFC*, 2016, pp. Th1A–3.
- [401] R. Muñoz *et al.*, "The need for a transport API in 5G networks: the control orchestration protocol," in *Proc. OSA OFC*. Optical Society of America, 2016, pp. Th3K–4.
- [402] A. Felix *et al.*, "Multi-layer SDN on a commercial network control platform for packet optical networks," in *Proc. IEEE OFC*, Mar. 2014, pp. 1–3.
- [403] M. Gerola *et al.*, "Demonstrating inter-testbed network virtualization in OFELIA SDN experimental facility," in *Proc. IEEE Conf. on Computer Commun. Workshops (INFOCOM WKSHPS)*, 2013, pp. 39–40.
- [404] S. Salsano, N. Blefari-Melazzi, A. Detti, G. Morabito, and L. Veltri, "Information centric networking over SDN and OpenFlow: Architectural aspects and experiments on the OFELIA testbed," *Computer Networks*, vol. 57, no. 16, pp. 3207–3221, 2013.
- [405] M. Suñé *et al.*, "Design and implementation of the OFELIA FP7 facility: The European OpenFlow testbed," *Computer Networks*, vol. 61, pp. 132–150, 2014.
- [406] M. Shirazipour, Y. Zhang, N. Beheshti, G. Lefebvre, and M. Tati-pamula, "OpenFlow and multi-layer extensions: Overview and next steps," in *Proc. Eu. Workshop on Software Defined Netw. (EWSDN)*, Oct. 2012, pp. 13–17.
- [407] O. Gerstel, V. Lopez, and D. Siracusa, "Multi-layer orchestration for application-centric networking," in *Proc. Int. Conf. on Photonics in Switching (PS)*, Sep. 2015, pp. 318–320.
- [408] M. Khaddam, L. Paraschis, and J. Finkelstein, "SDN multi-layer transport benefits, deployment opportunities, and requirements," in *Proc. IEEE Int. Conf. OFC*, Mar. 2015, pp. 1–3.
- [409] J. Liu *et al.*, "Experimental validation of IP over optical transport network based on hierarchical controlled software defined networks architecture," in *Proc. IEEE ICOCN*, Jul. 2015, pp. 1–3.
- [410] R. Vilalta *et al.*, "Network virtualization controller for abstraction and control of OpenFlow-enabled multi-tenant multi-technology transport networks," in *Proc. OSA OFC*, 2015, pp. Th3J–6.

- [411] R. Jing *et al.*, “Experimental demonstration of hierarchical control over multi-domain OTN networks based on extended OpenFlow protocol,” in *Proc. IEEE Conf. on OFC*, Mar. 2015, pp. 1–3.
- [412] Z. Zhu *et al.*, “Demonstration of cooperative resource allocation in an OpenFlow-controlled multidomain and multinational SD-EON testbed,” *IEEE/OSA J. Lightwave Techn.*, vol. 33, no. 8, pp. 1508–1514, April 2015.
- [413] R. Vilalta *et al.*, “Multidomain network hypervisor for abstraction and control of OpenFlow-enabled multitenant multitechnology transport networks [invited],” *IEEE/OSA J. Opt. Commun. Netw.*, vol. 7, no. 11, pp. B55–B61, 2015.
- [414] R. Muñoz *et al.*, “Transport network orchestration for end-to-end multilayer provisioning across heterogeneous SDN/OpenFlow and GMPLS/PCE control domains,” *IEEE/OSA J. Lightwave Techn.*, vol. 33, no. 8, pp. 1540–1548, April 2015.
- [415] L. Liu, “SDN orchestration for dynamic end-to-end control of data center multi-domain optical networking,” *China Commun.*, vol. 12, no. 8, pp. 10–21, August 2015.
- [416] A. Mayoral, R. Vilalta, R. Muñoz, R. Casellas, and R. Martínez, “SDN orchestration architectures and their integration with cloud computing applications,” *Opt. Sw. Netw.*, in print, 2016.
- [417] R. Casellas *et al.*, “SDN orchestration of OpenFlow and GMPLS flexi-grid networks with a stateful hierarchical PCE [invited],” *IEEE/OSA J. Opt. Commun. Netw.*, vol. 7, no. 1, pp. A106–A117, 2015.
- [418] R. Muñoz *et al.*, “Integrated SDN/NFV management and orchestration architecture for dynamic deployment of virtual SDN control instances for virtual tenant networks [invited],” *IEEE/OSA J. Opt. Commun. Netw.*, vol. 7, no. 11, pp. B62–B70, 2015.
- [419] R. Vilalta, A. Mayoral, R. Muñoz, R. Casellas, and R. Martínez, “Multitenant transport networks with SDN/NFV,” *IEEE/OSA J. Lightwave Techn.*, vol. 34, no. 6, pp. 1509–1515, March 2016.
- [420] A. Mayoral, R. Vilalta, R. Casellas, R. Muñoz, and R. Martínez, “Traffic engineering enforcement in multi-domain SDN orchestration of multi-layer (packet/optical) networks,” in *Proc. IEEE ECOC*, Sep. 2015, pp. 1–3.
- [421] R. Muñoz, R. Vilalta, R. Casellas, and R. Martínez, “SDN orchestration and virtualization of heterogeneous multi-domain and multi-layer transport networks: The STRAUSS approach,” in *Proc. IEEE BlackSeaCom*, May 2015, pp. 142–146.
- [422] Y. Yu *et al.*, “Field demonstration of multi-domain software-defined transport networking with multi-controller collaboration for data center interconnection [invited],” *IEEE/OSA J. Opt. Commun. Netw.*, vol. 7, no. 2, pp. A301–A308, February 2015.
- [423] P. J. Argibay-Losada, Y. Yoshida, A. Maruta, M. Schlosser, and K. i. Kitayama, “Performance of fixed-length, variable-capacity packets in optical packet-switching networks,” *IEEE/OSA J. Opt. Commun. Netw.*, vol. 7, no. 7, pp. 609–617, Jul. 2015.
- [424] T. Szyrkowiec *et al.*, “Demonstration of SDN based optical network virtualization and multidomain service orchestration,” in *Proc. Eu. Workshop on Software Defined Netw. (EWSDN)*, Sep. 2014, pp. 137–138.
- [425] R. Vilalta *et al.*, “Hierarchical SDN orchestration of wireless and optical networks with E2E provisioning and recovery for future 5G networks,” in *Proc. OSA OFC*, 2016, pp. W2A–43.
- [426] D. King and A. Farrel, “A PCE-Based Architecture for Application-Based Network Operations,” Internet Requests for Comments, RFC Editor, RFC 7491, Mar. 2015. [Online]. Available: <http://www.rfc-editor.org/rfc/rfc7491.txt>
- [427] R. Martínez *et al.*, “Integrated SDN/NFV orchestration for the dynamic deployment of mobile virtual backhaul networks over a multi-layer (packet/optical) aggregation infrastructure,” in *Proc. OSA OFC*, 2016, pp. Th1A–1.
- [428] R. Zheng, W. Yang, and J. Zhou, “Future access architecture: Software-defined access networking,” in *Proc. IEEE CCNC*, Jan. 2014, pp. 881–886.
- [429] N. Blum, S. Dutkowski, and T. Magedanz, “InSeRt—an intent-based service request API for service exposure in next generation networks,” in *Proc. IEEE Software Engineering Workshop*, 2008, pp. 21–30.
- [430] R. Cohen *et al.*, “An intent-based approach for network virtualization,” in *Proc. IFIP/IEEE Int. Symp. on Integrated Network Management (IM)*, 2013, pp. 42–50.
- [431] C. Prakash *et al.*, “PGA: Using graphs to express and automatically reconcile network policies,” *ACM SIGCOMM Computer Commun. Rev.*, vol. 45, no. 5, pp. 29–42, Oct. 2015.
- [432] “OpenFlow 1.4,” 2015. [Online]. Available: http://flowgrammable.org/sdn/openflow/message-layer/#tab_ofp_1_4
- [433] D. Hu *et al.*, “Design and demonstration of SDN-based flexible flow converging with protocol-oblivious forwarding (POF),” in *Proc. IEEE GLOBECOM*, Dec. 2015, pp. 1–6.
- [434] K. Phemius, M. Bouet, and J. Leguay, “DISCO: Distributed multi-domain SDN controllers,” in *Proc. IEEE Network Operations and Management Symposium (NOMS)*, 2014, pp. 1–4.
- [435] P. Ohlen *et al.*, “Data plane and control architectures for 5G transport networks,” *IEEE/OSA J. Lightwave Techn.*, vol. 34, no. 6, pp. 1501–1508, March 2016.
- [436] V. Chandrasekhar, J. G. Andrews, and A. Gatherer, “Femtocell networks: a survey,” *IEEE Commun. Mag.*, vol. 46, no. 9, pp. 59–67, 2008.
- [437] H. ElSawy, E. Hossain, and M. Haenggi, “Stochastic geometry for modeling, analysis, and design of multi-tier and cognitive cellular wireless networks: A survey,” *IEEE Commun. Surv. & Tut.*, vol. 15, no. 3, pp. 996–1019, 2013.
- [438] M. Louta, P. Zournatzis, S. Kraounakis, P. Sarigiannidis, and I. Demetropoulos, “Towards realization of the ABC vision: A comparative survey of access network selection,” in *Proc. IEEE Symp. Computers and Commun. (ISCC)*, 2011, pp. 472–477.
- [439] M. Hasan, E. Hossain, and D. Niyato, “Random access for machine-to-machine communication in LTE-advanced networks: issues and approaches,” *IEEE Commun. Mag.*, vol. 51, no. 6, pp. 86–93, 2013.
- [440] A. Laya, L. Alonso, and J. Alonso-Zarate, “Is the random access channel of LTE and LTE-A suitable for M2M communications? a survey of alternatives,” *IEEE Commun. Surv. & Tut.*, vol. 16, no. 1, pp. 4–16, 2014.
- [441] M. P. Anastasopoulos *et al.*, “Optical wireless network convergence in support of energy-efficient mobile cloud services,” *Photonic Netw. Commun.*, vol. 29, no. 3, pp. 269–281, 2015.
- [442] Z. Hasan, H. Boostanimehr, and V. K. Bhargava, “Green cellular networks: A survey, some research issues and challenges,” *IEEE Commun. Surv. & Tut.*, vol. 13, no. 4, pp. 524–540, 2011.
- [443] Y. Shi, J. Zhang, and K. Letaief, “Group sparse beamforming for green cloud-RAN,” *IEEE Trans. Wireless Commun.*, vol. 13, no. 5, pp. 2809–2823, May 2014.
- [444] J. Wang, X. Chen, C. Phillips, and Y. Yan, “Energy efficiency with QoS control in dynamic optical networks with sdn enabled integrated control plane,” *Computer Networks*, vol. 78, pp. 57–67, 2015.
- [445] D. Butler, “SDN and NFV for broadcasters and media,” in *Proc. IEEE ECOC*, Sept 2015, pp. 1–3.
- [446] J. Ellerton *et al.*, “Prospects for software defined networking and network function virtualization in media and broadcast,” in *Proc. IEEE Techn. Conf. and Exhibition.*, 2015, pp. 1–21.
- [447] S. Azodolmolky *et al.*, “SONEP: A software-defined optical network emulation platform,” in *IEEE Int. Conf. on Optical Net. Design and Modeling*, May 2014, pp. 216–221.
- [448] “OFTest—Validating OpenFlow Switches.” [Online]. Available: <http://www.projectfloodlight.org/oftest/>
- [449] C. Rotsos, G. Antichi, M. Bruyere, P. Owezarski, and A. W. Moore, “An open testing framework for next-generation OpenFlow switches,” in *Proc. IEEE Eu. Workshop on Software Defined Netw. (EWSDN)*, 2014, pp. 127–128.
- [450] M. Jarschel, F. Lehrieder, Z. Magyari, and R. Pries, “A flexible OpenFlow-controller benchmark,” in *Proc. IEEE Eu. Workshop on Software Defined Netw. (EWSDN)*, 2012, pp. 48–53.
- [451] M. Jarschel, C. Metter, T. Zinner, S. Gebert, and P. Tran-Gia, “OFProbe: A platform-independent tool for OpenFlow controller analysis,” in *Proc. IEEE Int. Conf. on Commun. and Electronics (ICCE)*, 2014, pp. 182–187.