

BIBΛΙΑ:

ΔΙΚΤΥΑ ΕΠΙΚΟΙΝΩΝΙΩΝ/ΕΠΙΚΟΙΝΩΝΙΑΣ ΥΠΟΛΟΓΙΣΤΩΝ

(TEXTBOOKS ON: Computer Networks)

- James Kurose, Keith Rose,
«Computer Networking: A Top-Down
Approach Featuring the Internet».
- Andrew S. Tanenbaum,
«Computer Networks».

Πολλές εκδόσεις και τα δύο!

ΠΟΥ ΑΛΛΟΥ ΔΙΔΑΣΚΕΤΑΙ ΤΟ 1^ο ΒΙΒΛΙΟ

(ενδεικτικά στην ΕΛΛΑΔΑ):

ΩΣ ΠΡΩΤΗ ΕΠΙΛΟΓΗ ΒΙΒΛΙΟΥ

- **ΕΘΝΙΚΟ & ΚΑΠΟΔΙΣΤΡΙΑΚΟ ΠΑΝΕΠΙΣΤΗΜΙΟ
ΑΘΗΝΩΝ ΠΛΗΡΟΦΟΡΙΚΗΣ ΚΑΙ ΤΗΛΕΠΙΚΟΙΝΩΝΙΩΝ**
- **Ε.Μ.Π. - ΗΛΕΚΤΡΟΛΟΓΟΙ**
Μάθημα [3298]: ΔΙΚΤΥΑ ΥΠΟΛΟΓΙΣΤΩΝ
- **ΑΙΣΤΟΤΕΛΕΙΟ ΠΑΝΕΠΙΣΤΗΜΙΟ ΘΕΣΣΑΛΟΝΙΚΗΣ**
Μάθημα [ΤΗ0501]: Δίκτυα Τηλεπικοινωνιών

ΠΡΟΣΩΠΙΚΑ ΑΠΟ ΤΟ 2000!

ΠΟΥ ΑΛΛΟΥ ΔΙΔΑΣΚΕΤΑΙ ΤΟ 1^Ο ΒΙΒΛΙΟ

(ΕΝΔΕΙΚΤΙΚΑ ΣΤΟ ΕΞΩΤΕΡΙΚΟ):

Columbia University (USA): <http://www.cs.columbia.edu/~danr/4119/4119-info.pdf>

Stanford University (USA): <http://www.scs.stanford.edu/08sp-cs144/notes/l1.pdf>

Tufts University (USA): <http://www.cs.tufts.edu/comp/112/>

University of California at Santa Barbara (USA):

<http://www.cs.ucsb.edu/~almeroth/classes/S06.176A>

University of California at Berkley (USA):

http://www.google.gr/url?sa=t&rct=j&q=where%20the%20book%20of%20kurose%20-%20ross%20%22computer%20networking%22%20is%20taught&source=web&cd=7&ved=0CF8QFjAG&url=http%3A%2F%2Fwww-inst.eecs.berkeley.edu%2F~ee122%2Ffa10%2Fnotes%2F01-Overview.ppt&ei=nNT1T_mOCKn74QT5-zsBg&usg=AFQjCNH4Q_ApOrmHK0pyAZFLw9uiO7-Djg

New York University (USA): <http://www.nyu.edu/classes/jcf/CSCI-GA.2262-001/index.html>

The University of Texas at Austin (USA): <http://www.cs.utexas.edu/~vin/Classes/CS386M-Fall04/>

Ira A. Fulton Schools of Engineering at Arizona State University (USA):

<http://enpub.fulton.asu.edu/iacdev/courses/eee459/home.html>

The University of Utah (USA): <http://www.eng.utah.edu/~cs5480/>

Rose-Hulman Institute of Technology (USA):

<http://www.rose-hulman.edu/class/csse/csse432/201230/syllabus.html>

University of Saarlandes (Germany): <http://depend.cs.uni-sb.de/index.php?413>

University of Torino (Italy):

<http://disi.unitn.it/locigno/index.php/teaching-duties/advanced-networking/advanced-networkingaa09-10>

Part I: Introduction

Chapter goal:

- ❑ get context, overview, “feel” of networking
- ❑ more depth, detail *later* in course
- ❑ approach:
 - descriptive
 - use Internet as example

Overview:

- ❑ what's the Internet
- ❑ what's a protocol?
- ❑ network edge
- ❑ network core
- ❑ access net, physical media
- ❑ performance: loss, delay
- ❑ protocol layers, service models
- ❑ backbones, NAPs, ISPs
- ❑ history
- ❑ ATM network

Παράδειγμα Δικτύου

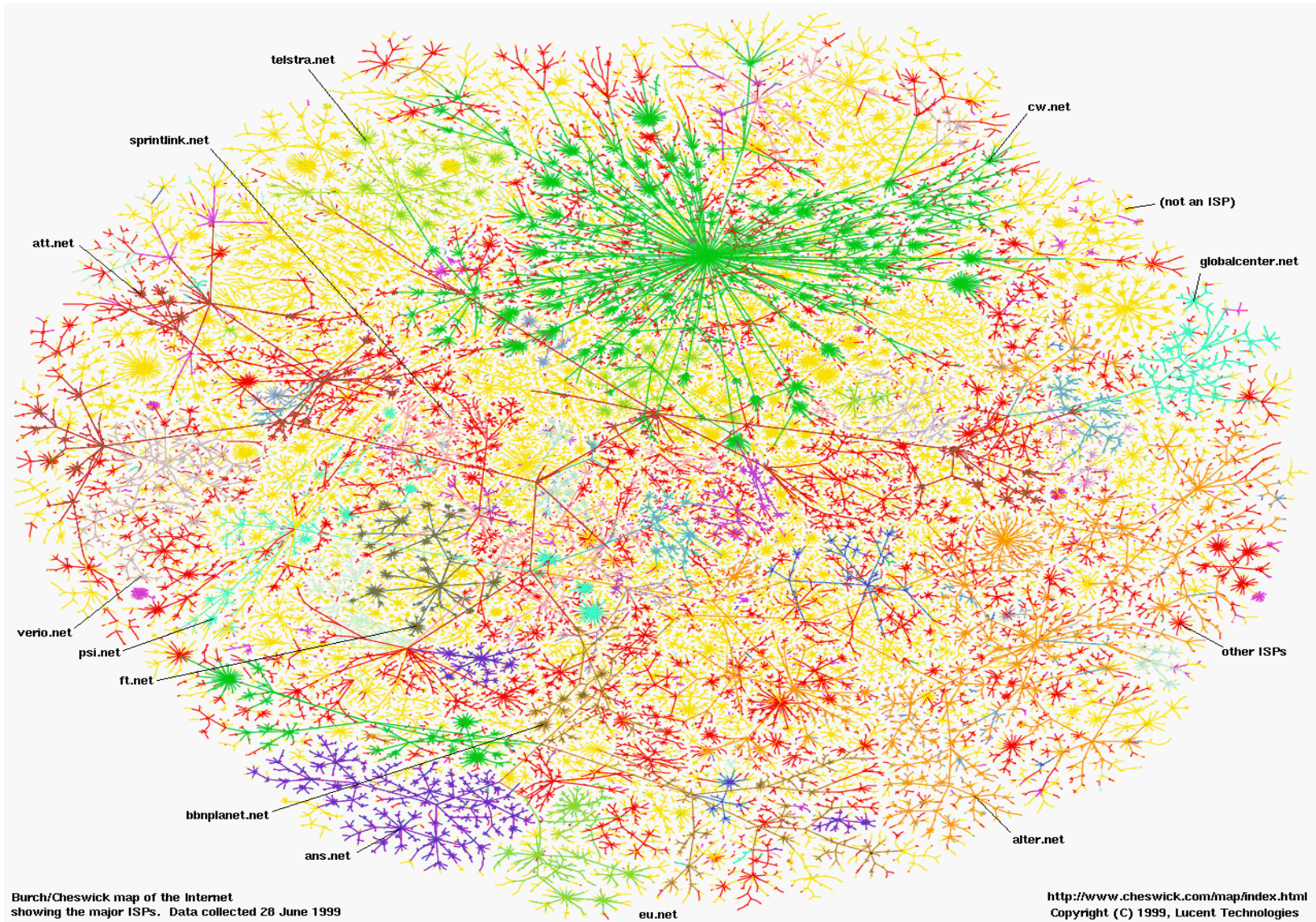

What's the Internet: "nuts and bolts" view

- millions of connected computing devices: *hosts, end-systems*
 - pc's workstations, servers
 - PDA's phones, toasters running *network apps*
- *communication links*
 - fiber, copper, radio, satellite
- *routers*: forward packets (chunks) of data thru network

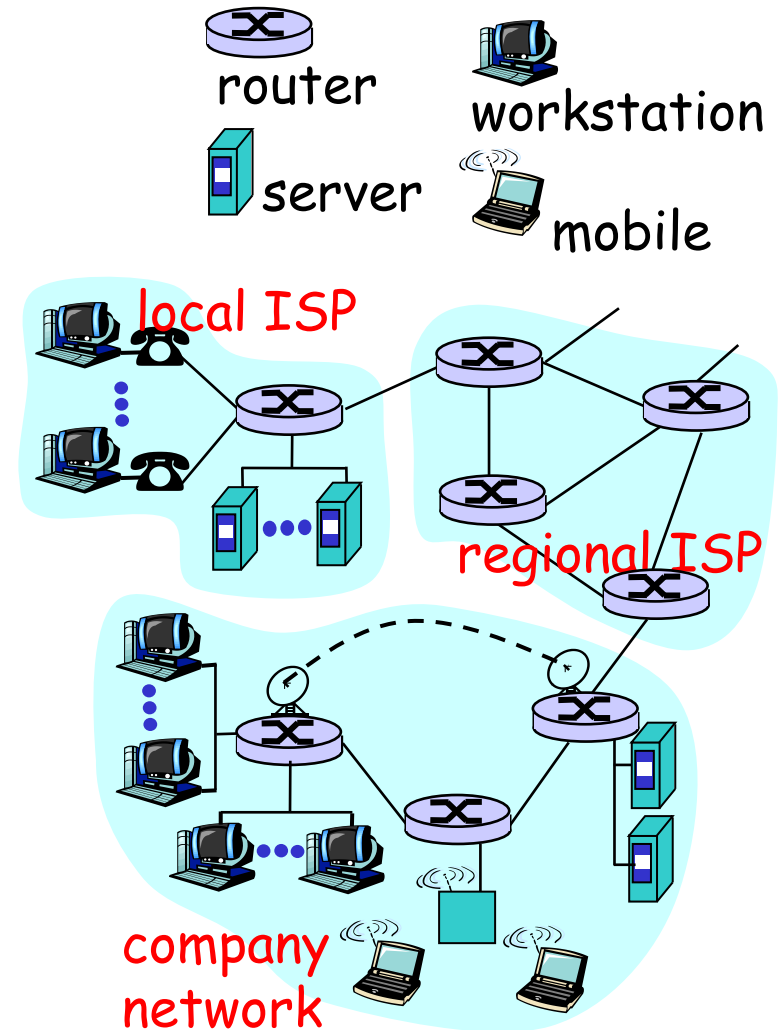

What's the Internet: "nuts and bolts" view

- **protocols:** control sending, receiving of msgs
 - e.g., TCP, IP, HTTP, FTP, PPP
- **Internet: "network of networks"**
 - loosely hierarchical
 - public Internet versus private intranet
- **Internet standards**
 - RFC: Request for comments
 - IETF: Internet Engineering Task Force

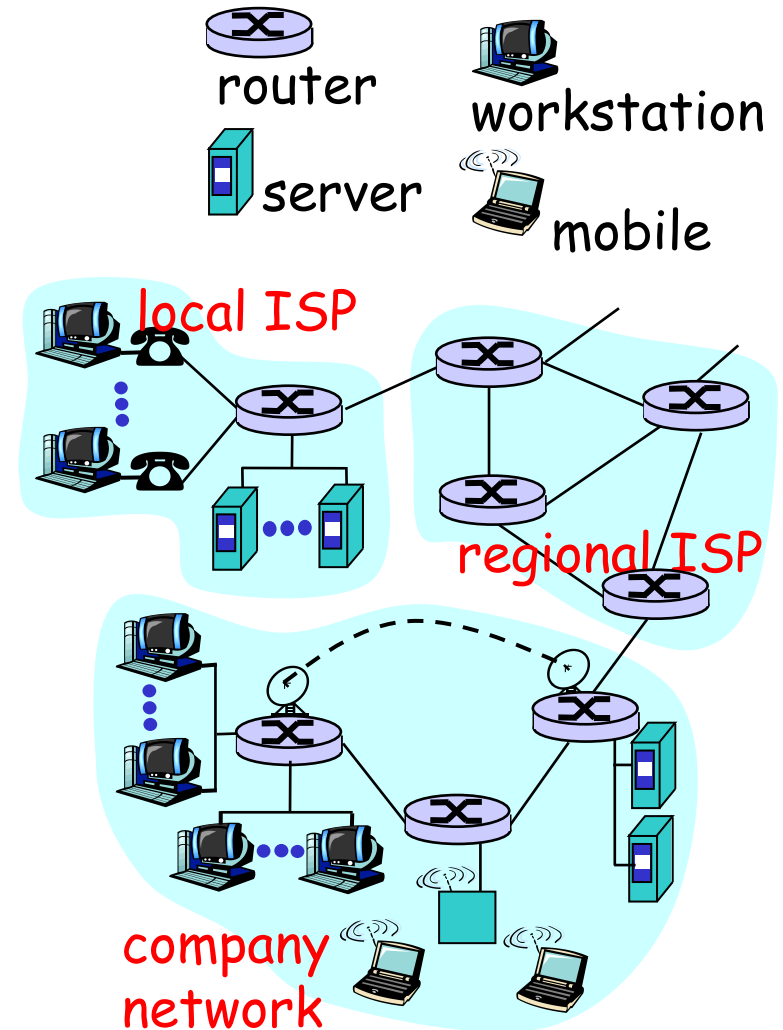

What's the Internet: a service view

- **communication infrastructure** enables distributed applications:
 - WWW, email, games, e-commerce, database., voting,
 - more?
- **communication services provided:**
 - connectionless
 - connection-oriented
- **cyberspace [Gibson]:**

"a consensual hallucination experienced daily by billions of operators, in every nation,"

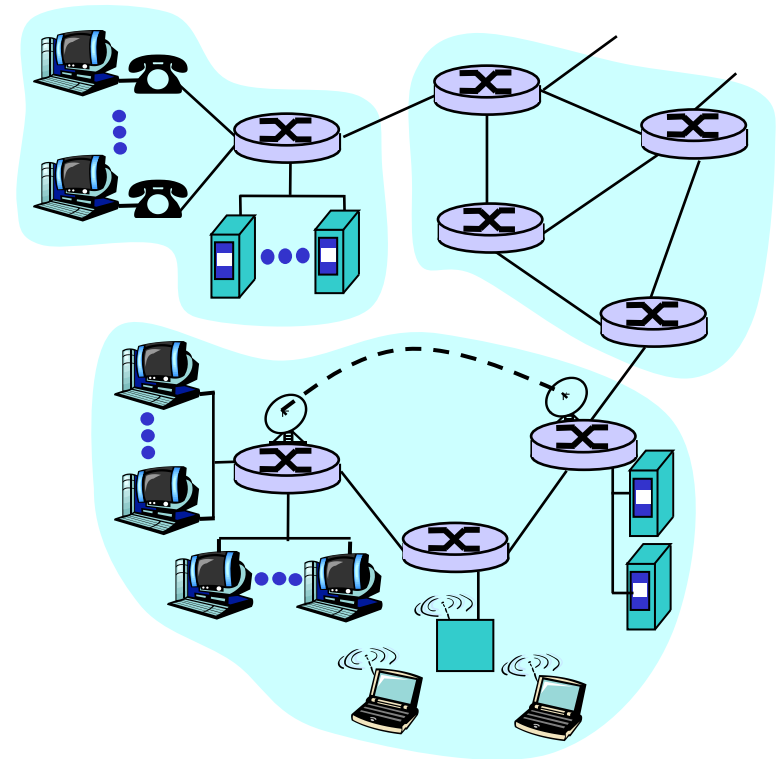

What's a protocol?

human protocols:

- ❑ "what's the time?"
- ❑ "I have a question"
- ❑ introductions

... specific msgs sent

... specific actions taken
when msgs received,
or other events

network protocols:

- ❑ machines rather than humans
- ❑ all communication activity in Internet governed by protocols

*protocols define format,
order of msgs sent and
received among network
entities, and actions
taken on msg
transmission, receipt*

What's a protocol?

a human protocol and a computer network protocol:

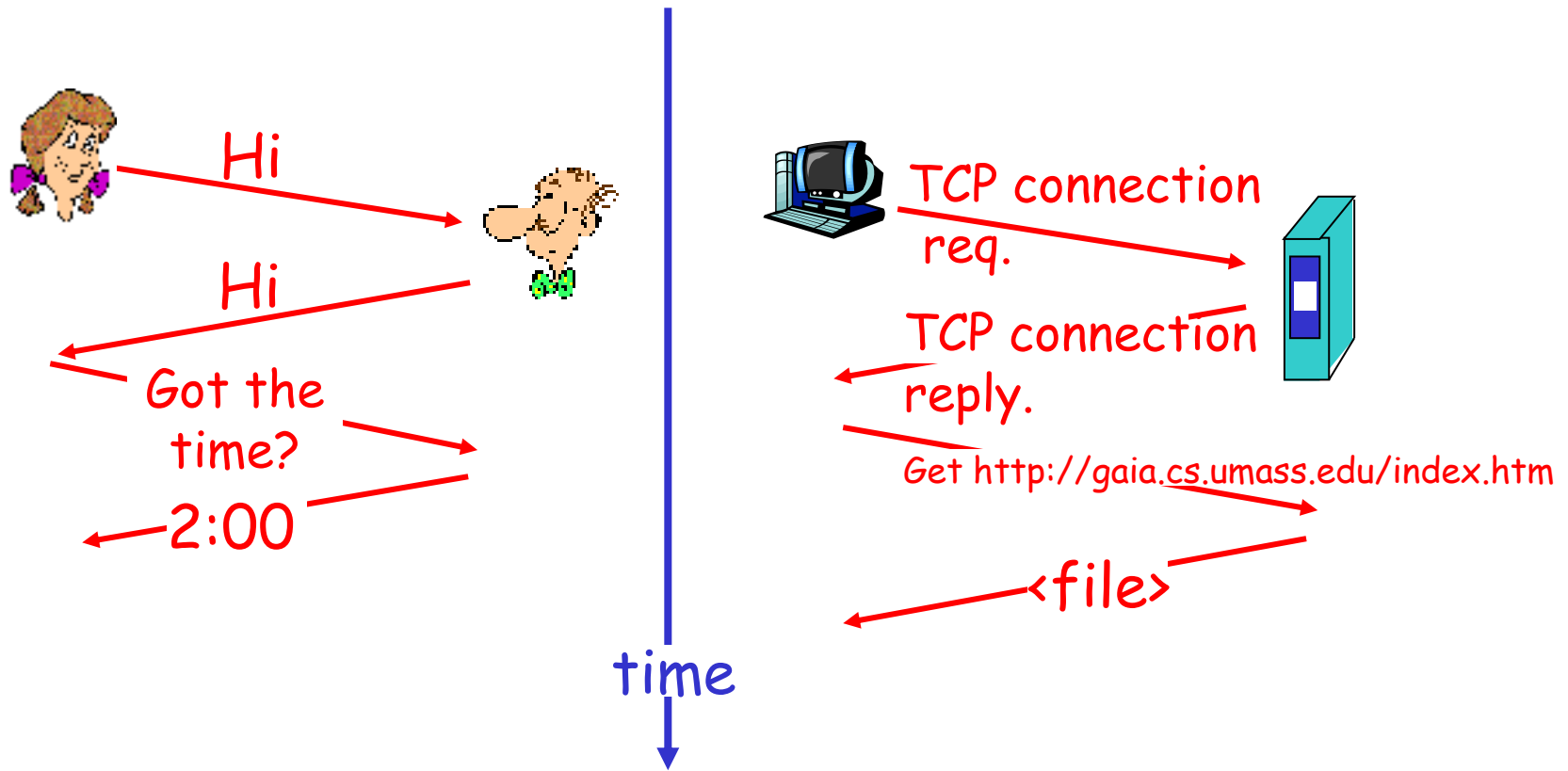

Q: Other human protocol?

A closer look at network structure:

- **network edge:**
applications and hosts
- **network core:**
 - routers
 - network of networks
- **access networks, physical media:**
communication links

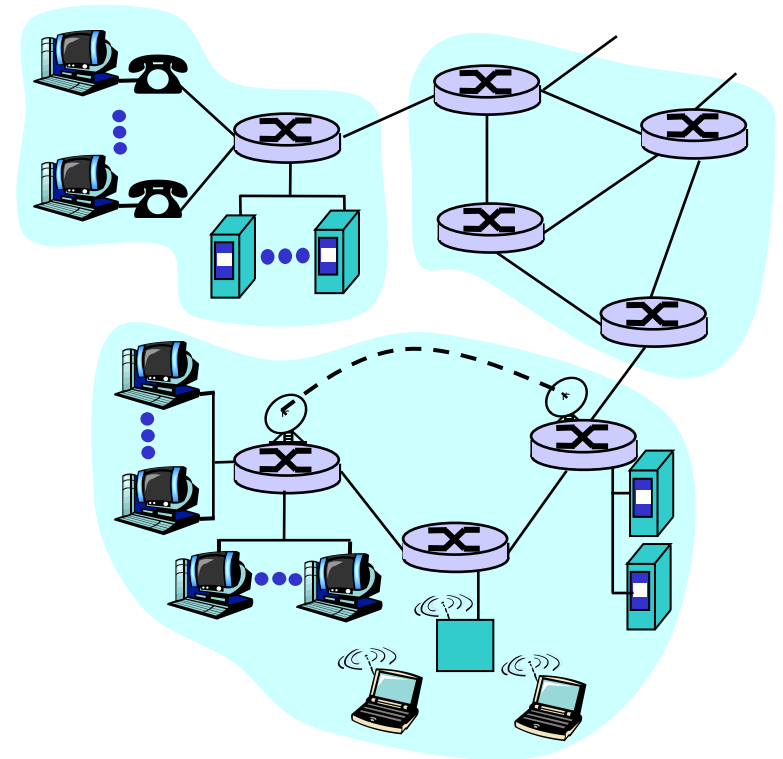

The network edge:

□ end systems (hosts):

- run application programs
- e.g., WWW, email
- at "edge of network"

□ client/server model

- client host requests, receives service from server
- e.g., WWW client (browser)/server; email client/server

□ peer-peer model:

- host interaction symmetric
- e.g.: teleconferencing

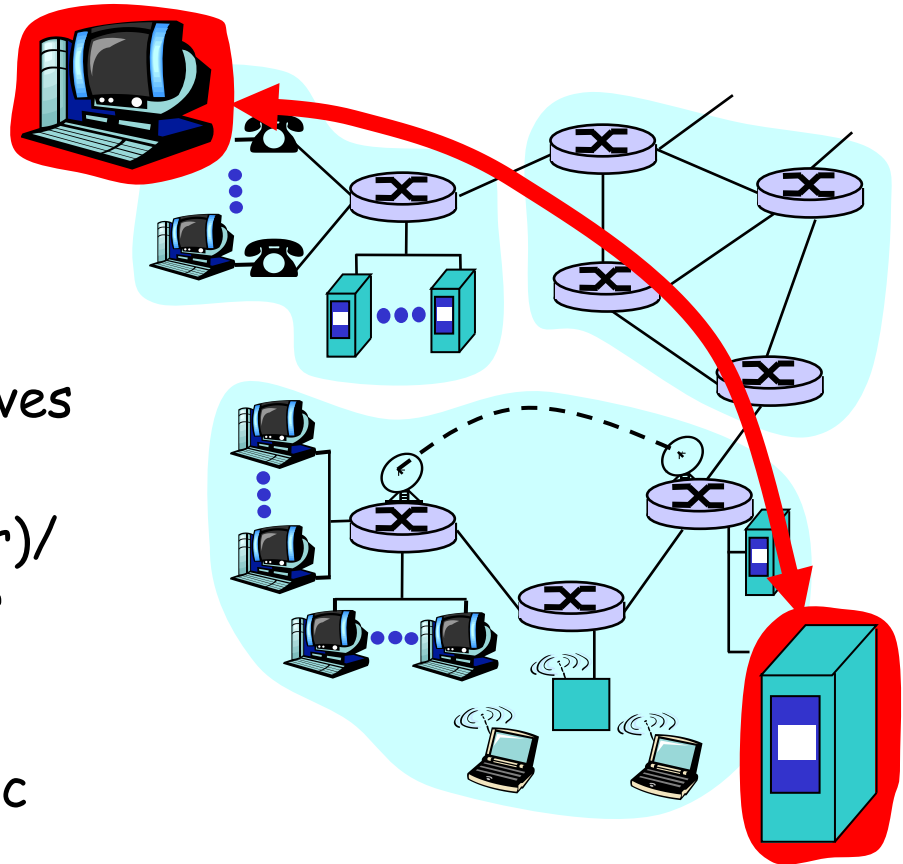

Network edge: connection-oriented service

- Goal: data transfer between end sys.
- ❑ *handshaking*: setup (prepare for) data transfer ahead of time
 - Hello, hello back human protocol
 - *set up "state"* in two communicating hosts
- ❑ TCP - Transmission Control Protocol
 - Internet's connection-oriented service

TCP service [RFC 793]

- ❑ *reliable, in-order* byte-stream data transfer
 - loss: acknowledgements and retransmissions
- ❑ *flow control*:
 - sender won't overwhelm receiver
- ❑ *congestion control*:
 - senders "slow down sending rate" when network congested

Network edge: connectionless service

Goal: data transfer
between end systems

- same as before!

□ **UDP** - User Datagram Protocol [RFC 768]:
Internet's
connectionless service

- unreliable data transfer
- no flow control
- no congestion control

App's using TCP:

- HTTP (WWW), FTP (file transfer), Telnet (remote login), SMTP (email)

App's using UDP:

- streaming media, teleconferencing, Internet telephony

The Network Core

- ❑ mesh of interconnected routers
- ❑ the fundamental question: how is data transferred through net?
 - circuit switching: dedicated circuit per call: telephone net
 - packet-switching: data sent thru net in discrete "chunks"

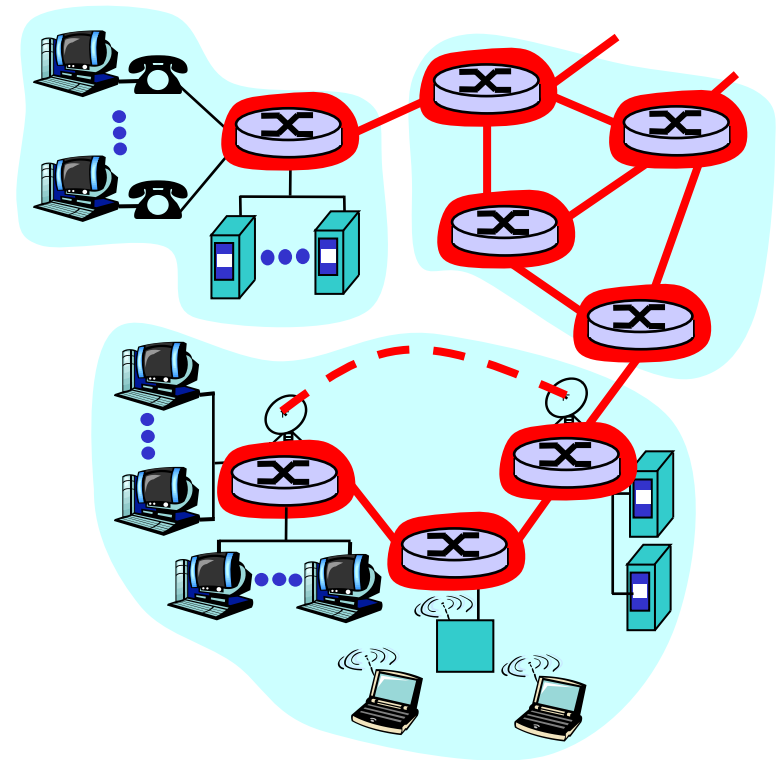

Network Core: Circuit Switching

End-end resources reserved for "call"

- ❑ link bandwidth, switch capacity
- ❑ dedicated resources: no sharing
- ❑ circuit-like (guaranteed) performance
- ❑ call setup required

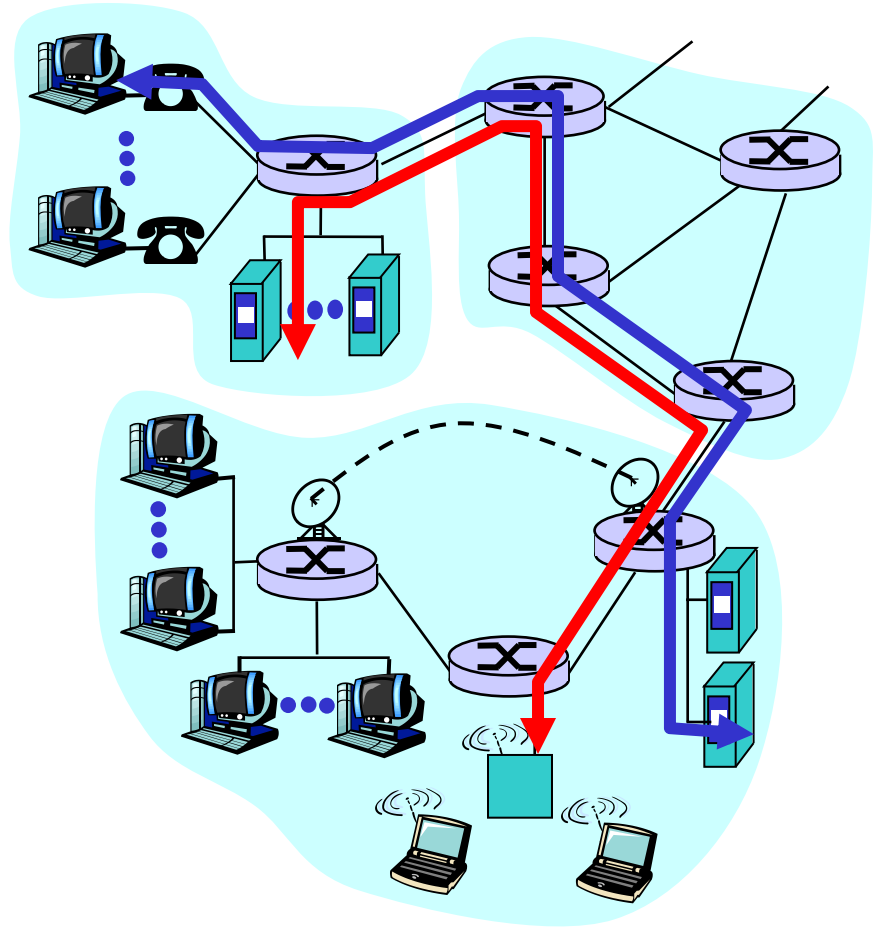

Network Core: Circuit Switching

network resources

(e.g., bandwidth)

divided into "pieces"

- ❑ pieces allocated to calls
- ❑ resource piece *idle* if not used by owning call (*no sharing*)
- ❑ dividing link bandwidth into "pieces"
 - frequency division
 - time division

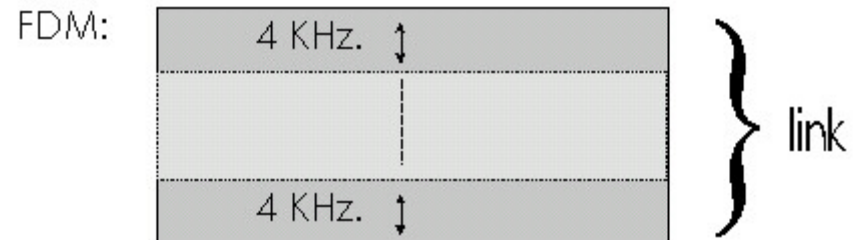

TDM:



All slots labelled  are dedicated to a specific sender-receiver pair.

Circuit switching: FDM versus TDM

FDM

Example:

4 users

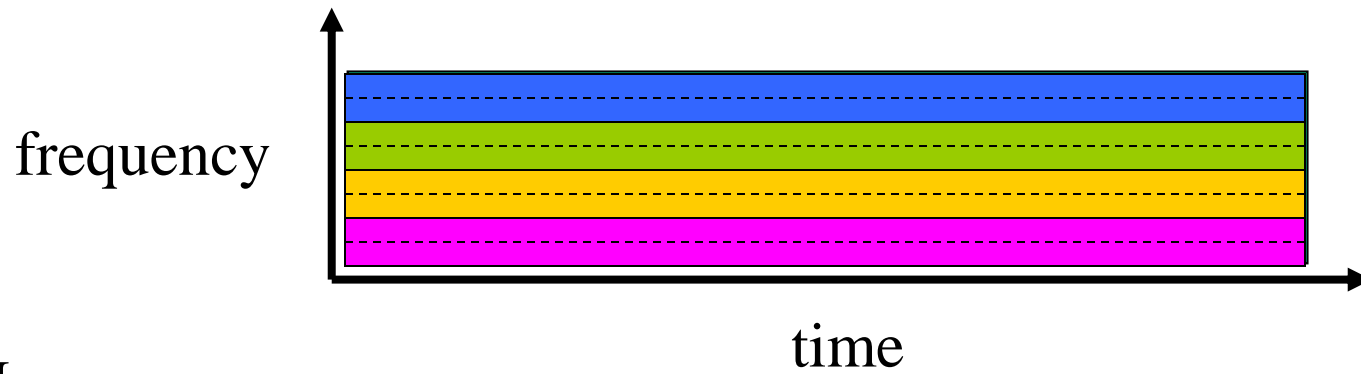

TDM

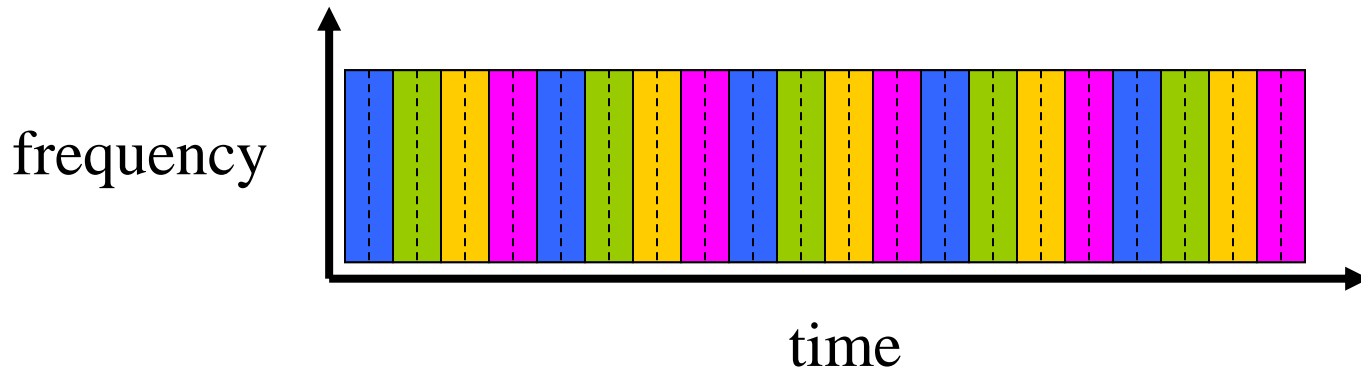

Network Core: Packet Switching

each end-end data stream
divided into *packets*

- ❑ user A, B packets *share* network resources
- ❑ each packet uses full link bandwidth
- ❑ resources used *as needed*,

resource contention:

- ❑ aggregate resource demand can exceed amount available
- ❑ congestion: packets queue, wait for link use
- ❑ store and forward: packets move one hop at a time
 - transmit over link
 - wait turn at next link

Bandwidth division into "pieces"
Dedicated allocation
Resource reservation



Network Core: Packet Switching

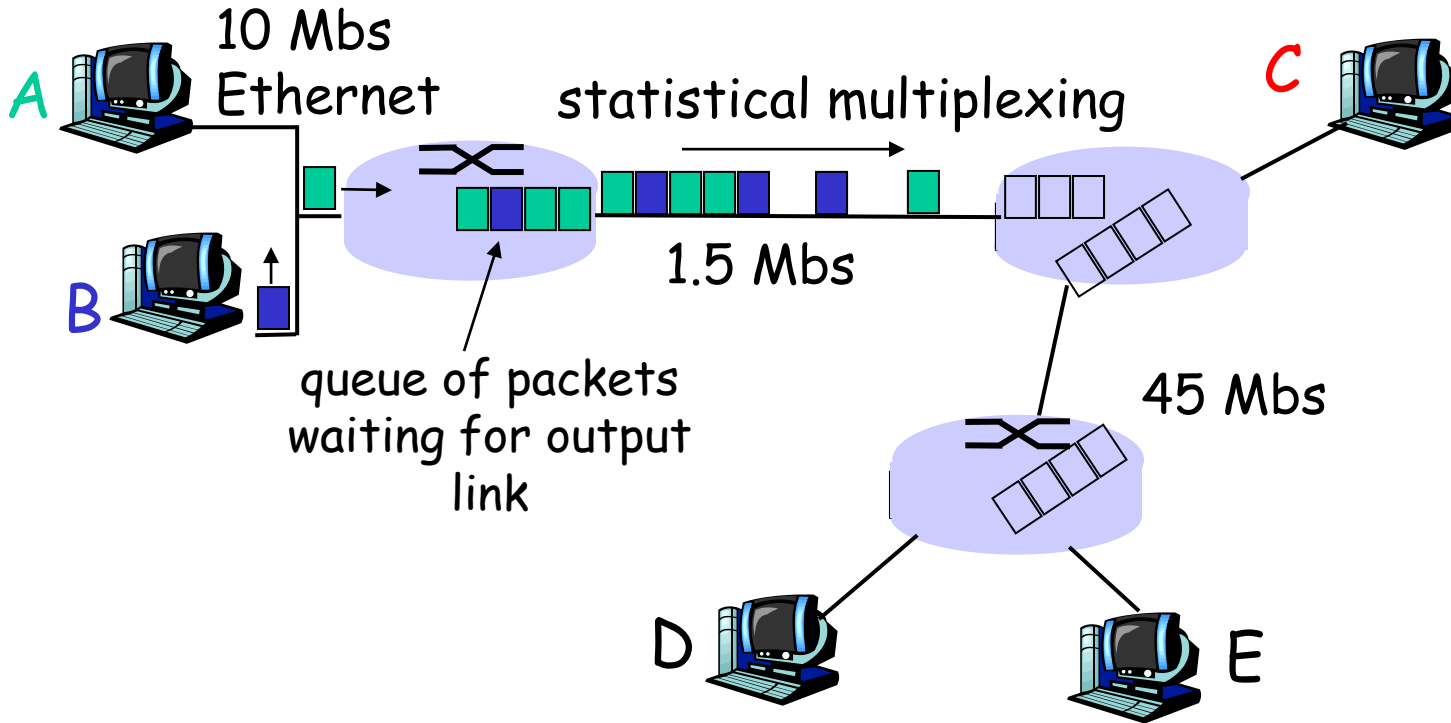

Packet-switching versus circuit switching: human restaurant analogy

- other human analogies?

Network Core: Packet Switching

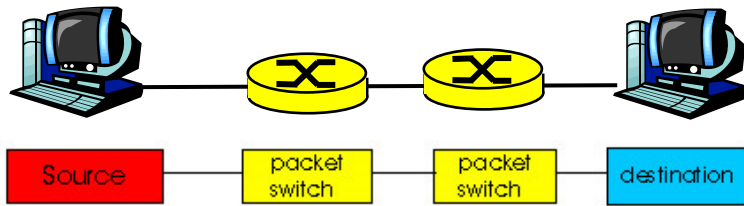

Packet-switching:
store and forward behavior

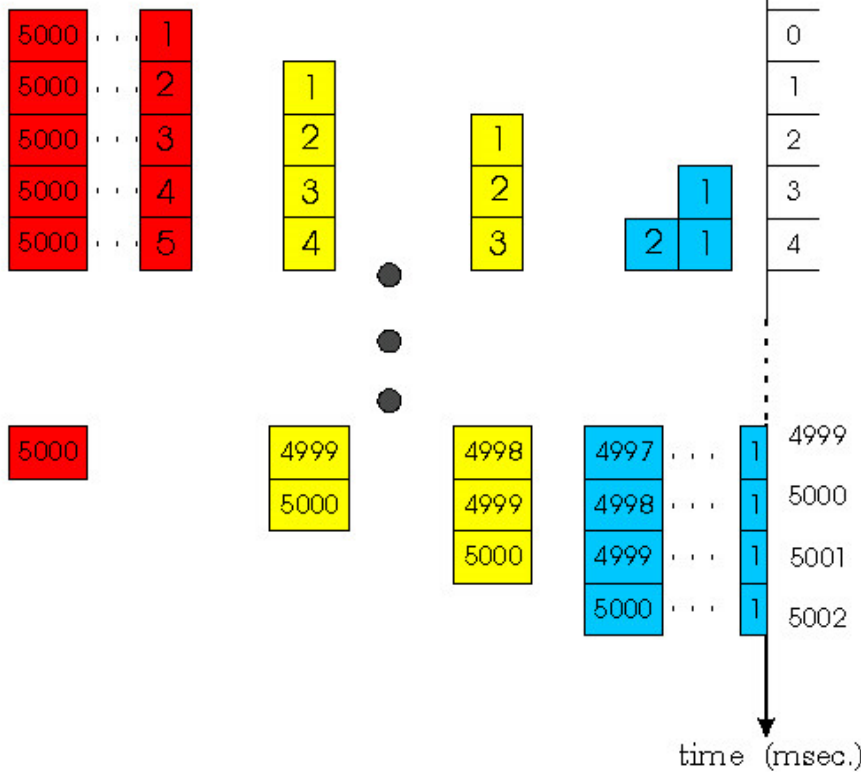

Packet switching versus circuit switching

Packet switching allows more users to use network!

- ❑ 1 Mbit link
- ❑ each user:
 - 100Kbps when "active"
 - active 10% of time
- ❑ circuit-switching:
 - 10 users
- ❑ packet switching:
 - with 35 users,
probability > 10 active
less than .0004

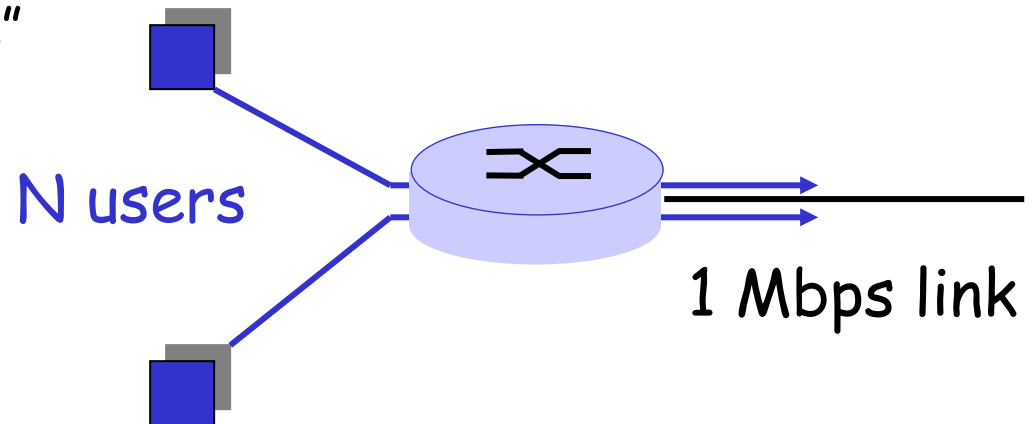

Packet switching versus circuit switching

Is packet switching a “slam dunk winner?”

- ❑ Great for bursty data
 - resource sharing
 - no call setup
- ❑ **Excessive congestion:** packet delay and loss
 - protocols needed for reliable data transfer, congestion control
- ❑ **Q: How to provide circuit-like behavior?**
 - bandwidth guarantees needed for audio/video apps

still an unsolved problem (chapter 6)

Packet-switched networks: routing

- ❑ **Goal:** move packets among routers from source to destination
 - we'll study several path selection algorithms (chapter 4)
- ❑ **datagram network:**
 - *destination address* determines next hop
 - routes may change during session
 - analogy: driving, asking directions
- ❑ **virtual circuit network:**
 - each packet carries tag (virtual circuit ID), tag determines next hop
 - fixed path determined at *call setup time*, remains fixed thru call
 - routers maintain per-call state

Access networks and physical media

Q: How to connection end systems to edge router?

- ❑ residential access nets
- ❑ institutional access networks (school, company)
- ❑ mobile access networks

Keep in mind:

- ❑ bandwidth (bits per second) of access network?
- ❑ shared or dedicated?

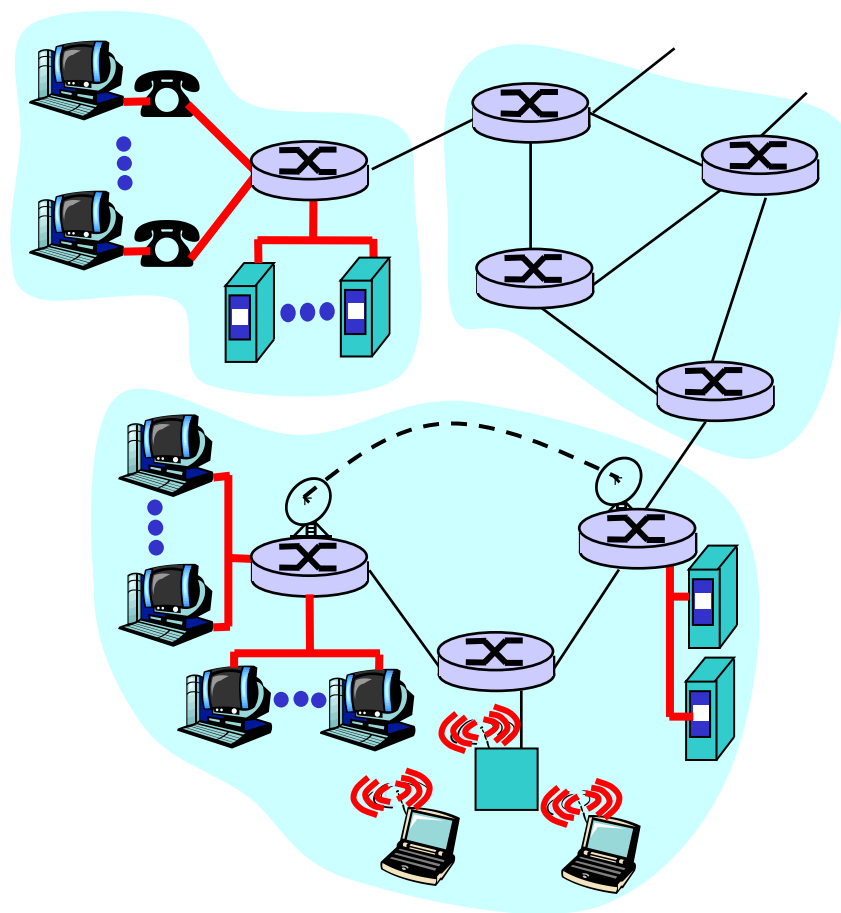

Residential access: point to point access

- ❑ **Dialup via modem**
 - up to 56Kbps direct access to router (conceptually)
- ❑ **ISDN**: intergrated services digital network: 128Kbps all-digital connect to router
- ❑ **ADSL**: asymmetric digital subscriber line
 - up to 2 Mbps home-to-router
 - up to 24 Mbps router-to-home
 - ADSL deployment: **UPDATE THIS**

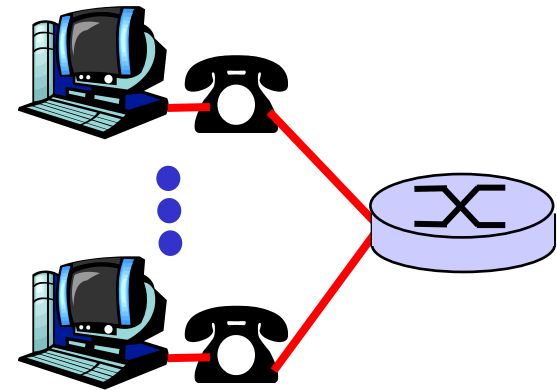

Residential access: cable modems

- **HFC: hybrid fiber coax**
 - asymmetric: up to 10Mbps upstream, 1 Mbps downstream
- **network** of cable and fiber attaches homes to ISP router
 - shared access to router among home
 - issues: congestion, dimensioning
- deployment: available via cable companies, e.g., MediaOne

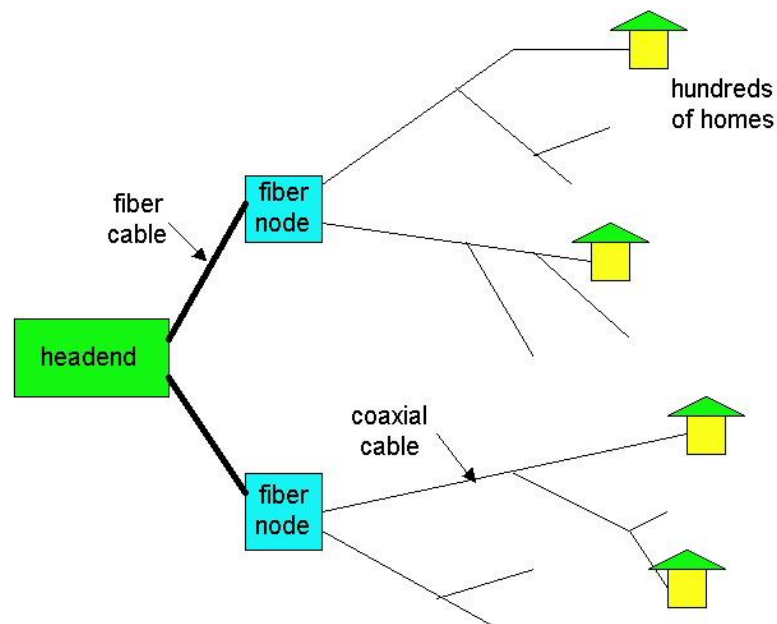

Institutional access: local area networks

- ❑ company/univ **local area network** (LAN) connects end system to edge router
- ❑ **Ethernet:**
 - shared or dedicated cable connects end system and router
 - 10 Mbs, 100Mbps, Gigabit Ethernet
- ❑ **deployment:** institutions, home LANs soon
- ❑ LANs: chapter 5

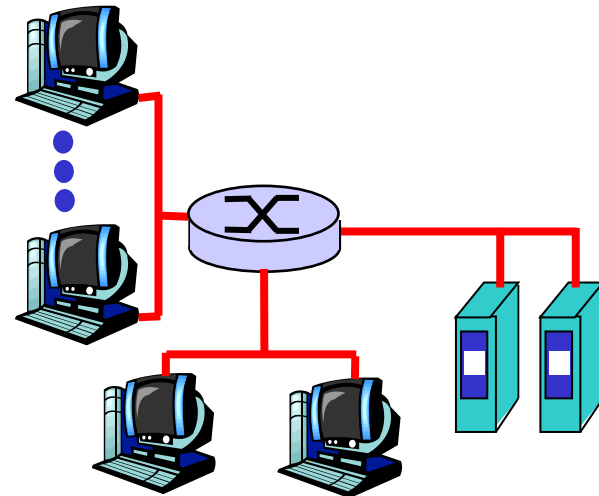

Wireless access networks

- ❑ shared *wireless* access network connects end system to router
- ❑ **wireless LANs:**
 - radio spectrum replaces wire
 - e.g., Lucent Wavelan 10 Mbps
- ❑ **wider-area wireless access**
 - CDPD: wireless access to ISP router via cellular network

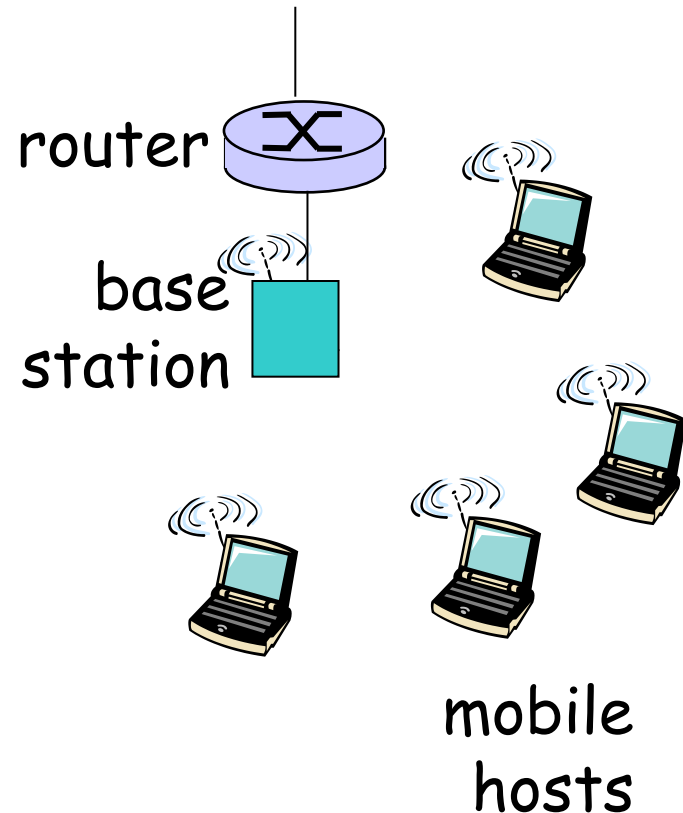

Physical Media

- ❑ **physical link:**
transmitted data bit propagates across link
- ❑ **guided media:**
 - signals propagate in solid media: copper, fiber
- ❑ **unguided media:**
 - signals propagate freely e.g., radio

Twisted Pair (TP)

- ❑ two insulated copper wires
 - Category 3: traditional phone wires, 10 Mbps ethernet
 - Category 5 TP: 100Mbps ethernet



Physical Media: coax, fiber

Coaxial cable:

- ❑ wire (signal carrier) within a wire (shield)
 - baseband: single channel on cable
 - broadband: multiple channel on cable
- ❑ bidirectional
- ❑ common use in 10Mbps Ethernet

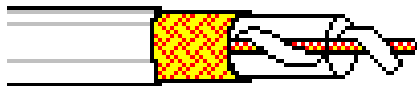

Fiber optic cable:

- ❑ glass fiber carrying light pulses
- ❑ high-speed operation:
 - 100Mbps Ethernet
 - high-speed point-to-point transmission (e.g., 5 Gps)
- ❑ low error rate



Physical media: radio

- ❑ signal carried in electromagnetic spectrum
- ❑ no physical "wire"
- ❑ bidirectional
- ❑ propagation environment effects:
 - reflection
 - obstruction by objects
 - interference

Radio link types:

- ❑ **microwave**
 - e.g. up to 45 Mbps channels
- ❑ **LAN** (e.g., waveLAN)
 - 2Mbps, 11Mbps
- ❑ **wide-area** (e.g., cellular)
 - e.g. CDPD, 10's Kbps
- ❑ **satellite**
 - up to 50Mbps channel (or multiple smaller channels)
 - 270 Msec end-end delay
 - geosynchronous versus LEOS

Delay in packet-switched networks

packets experience **delay**
on end-to-end path

□ **four** sources of delay
at each hop

□ nodal processing:

- check bit errors
- determine output link

□ queueing

- time waiting at output link for transmission
- depends on congestion level of router

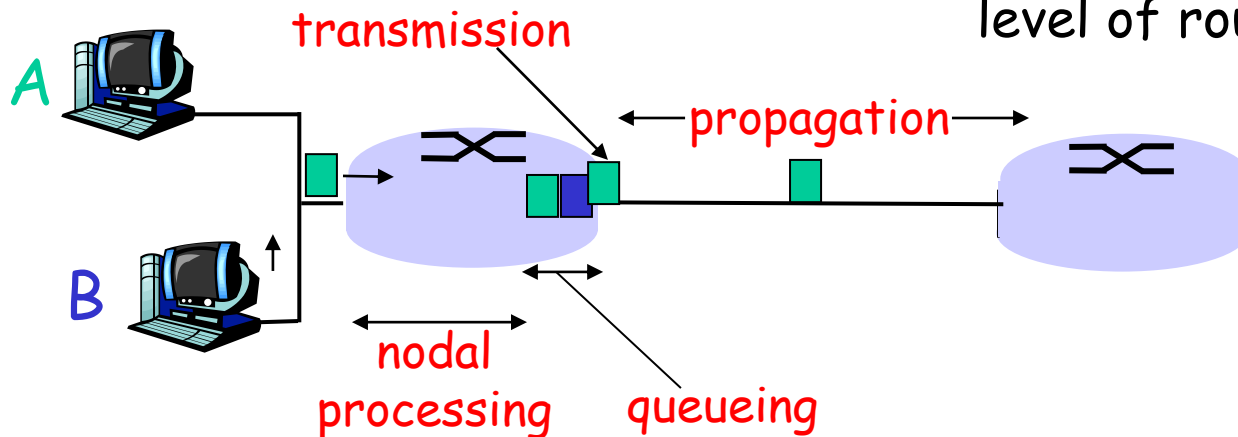

Delay in packet-switched networks

Transmission delay:

- R = link bandwidth (bps)
- L = packet length (bits)
- time to send bits into link = L/R

Propagation delay:

- d = length of physical link
- s = propagation speed in medium ($\sim 2 \times 10^8$ m/sec)
- propagation delay = d/s

Note: s and R are very different quantities!

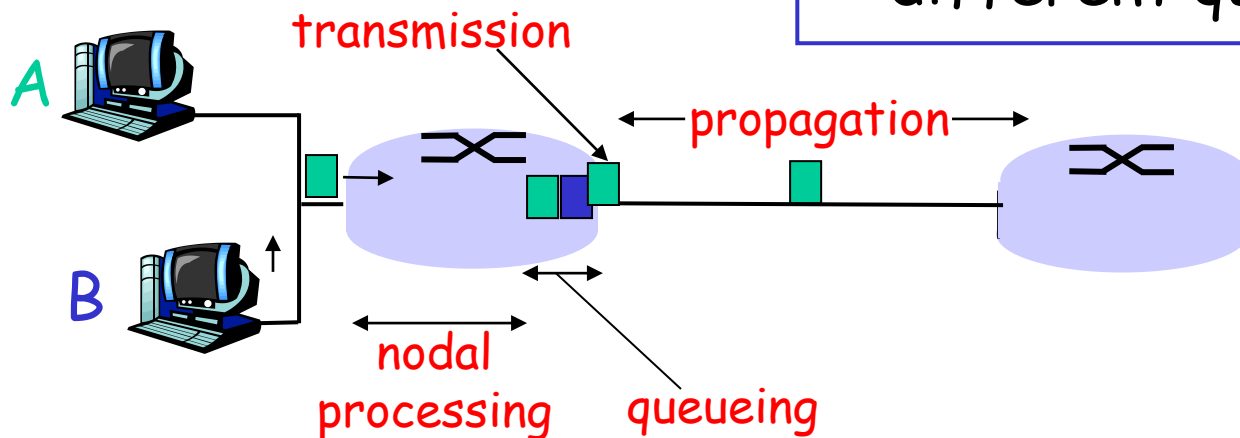

Queueing delay (revisited)

- R =link bandwidth (bps)
- L =packet length (bits)
- a =average packet arrival rate

traffic intensity = La/R

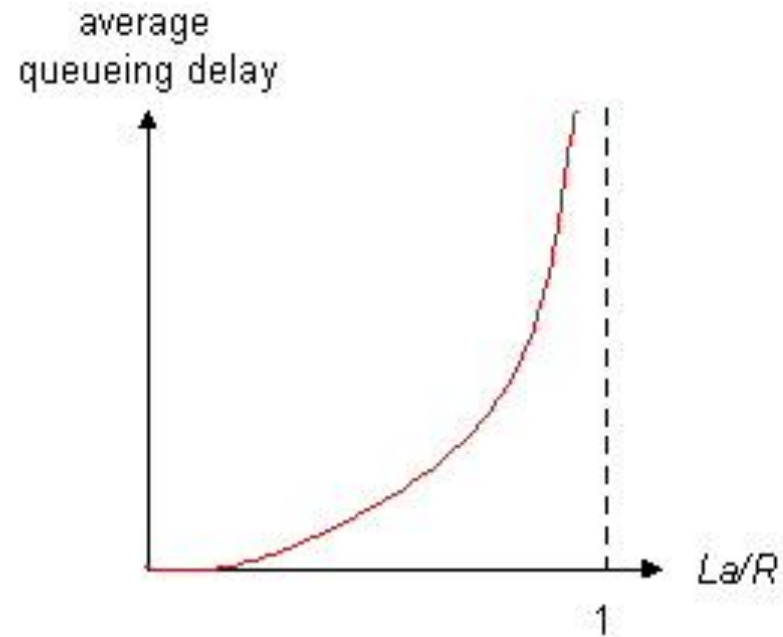

- $La/R \sim 0$: average queueing delay small
- $La/R \rightarrow 1$: delays become large
- $La/R > 1$: more "work" arriving than can be serviced, average delay infinite!

Δίκτυα πρόσβασης και φυσικά μέσα

Ε: Πως μπορεί να συνδεθεί ένα τερματικό σύστημα με τον περιφερειακό δρομολογητή του;

- ❖ Δίκτυα οικιακής πρόσβασης
- ❖ Δίκτυα εταιρικής πρόσβασης (σχολεία, εταιρείες)
- ❖ Δίκτυα ασύρματης πρόσβασης

Σημείωση:

- Εύρος ζώνης (bits per second) δικτύου πρόσβασης;
- Διαμοιραζόμενο (shared) ή αποκλειστικής χρήσης (dedicated);

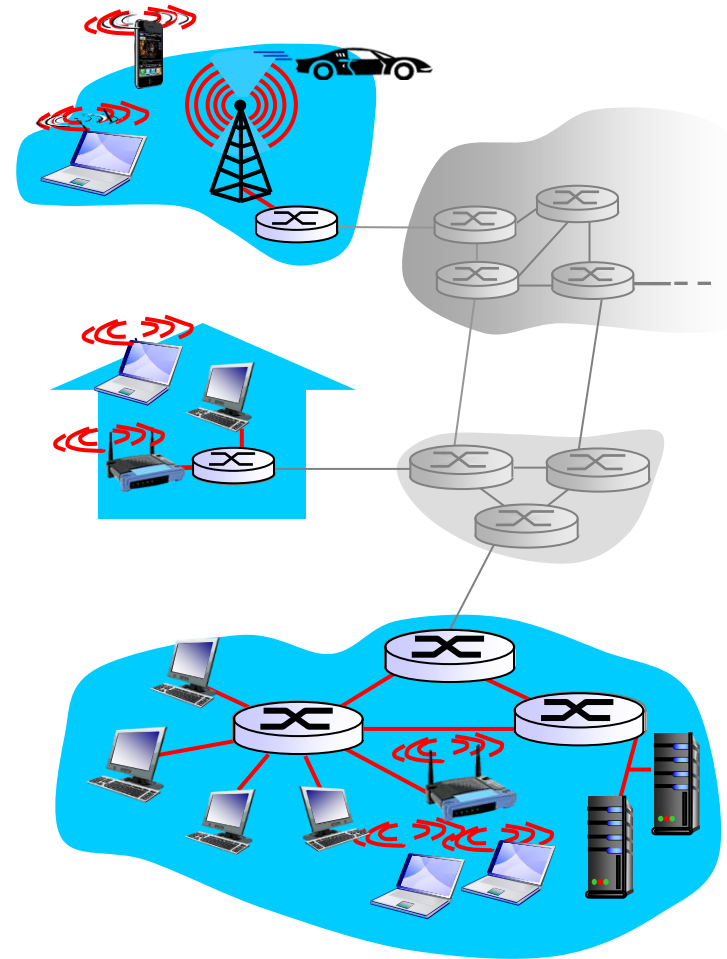

Πρόσβαση: Digital Subscriber Line (DSL)

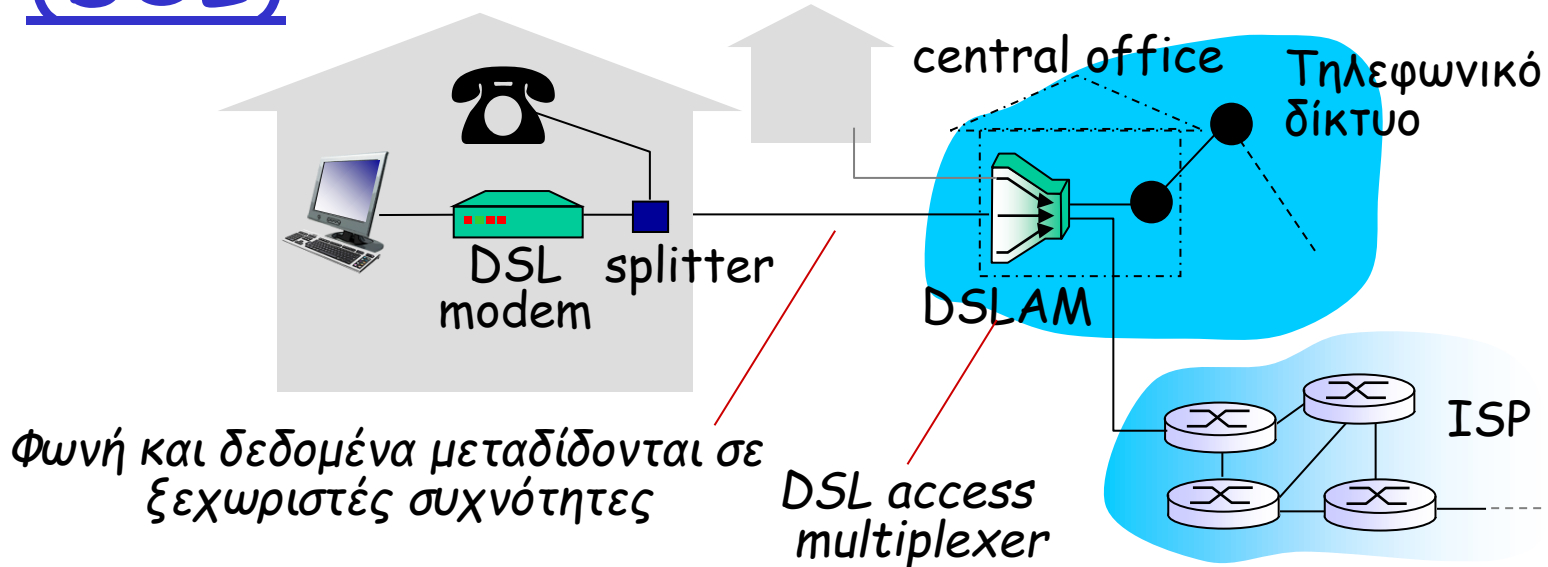

- ❖ Χρήση **υφιστάμενης** τηλεφωνικής γραμμής προς το DSLAM του κέντρου
 - Τα δεδομένα πάνω από την γραμμή DSL πάνε στο Διαδίκτυο
 - Η φωνή πάνω από την γραμμή DSL πάει στο τηλεφωνικό δίκτυο
- ❖ Upstream ρυθμός μετάδοσης < 2.5 Mbps (τυπικά < 1 Mbps)
- ❖ Downstream ρυθμός μετάδοσης < 24 Mbps (τυπικά < 10 Mbps)



Πρόσβαση: καλωδιακό δίκτυο

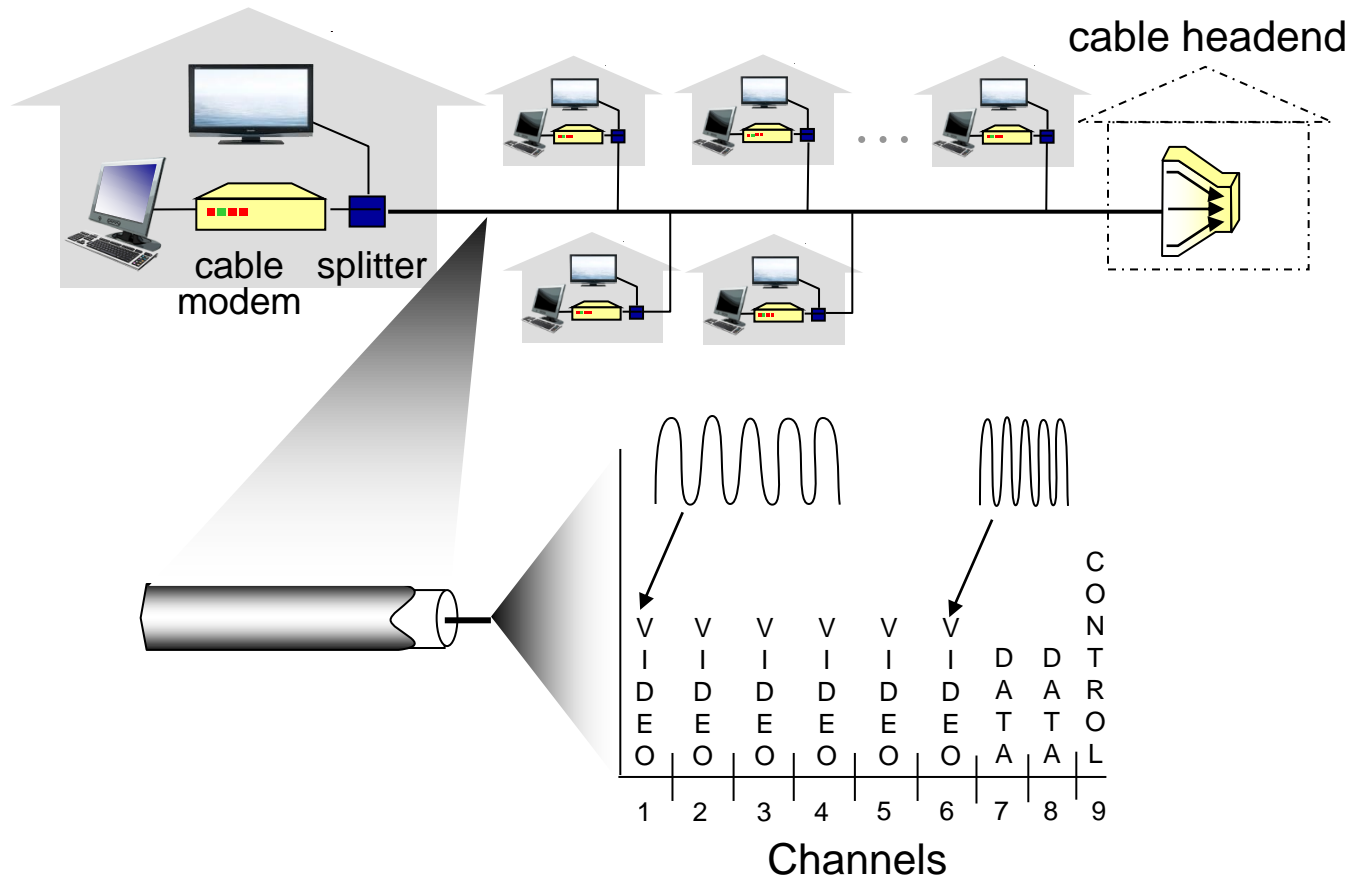

Πολύπλεξη διαίρεσης συχνότητας (*frequency division multiplexing*):
Διαφορετικά κανάλια μεταδίδονται σε διαφορετικές ζώνες συχνοτήτων



Πρόσβαση: καλωδιακό δίκτυο

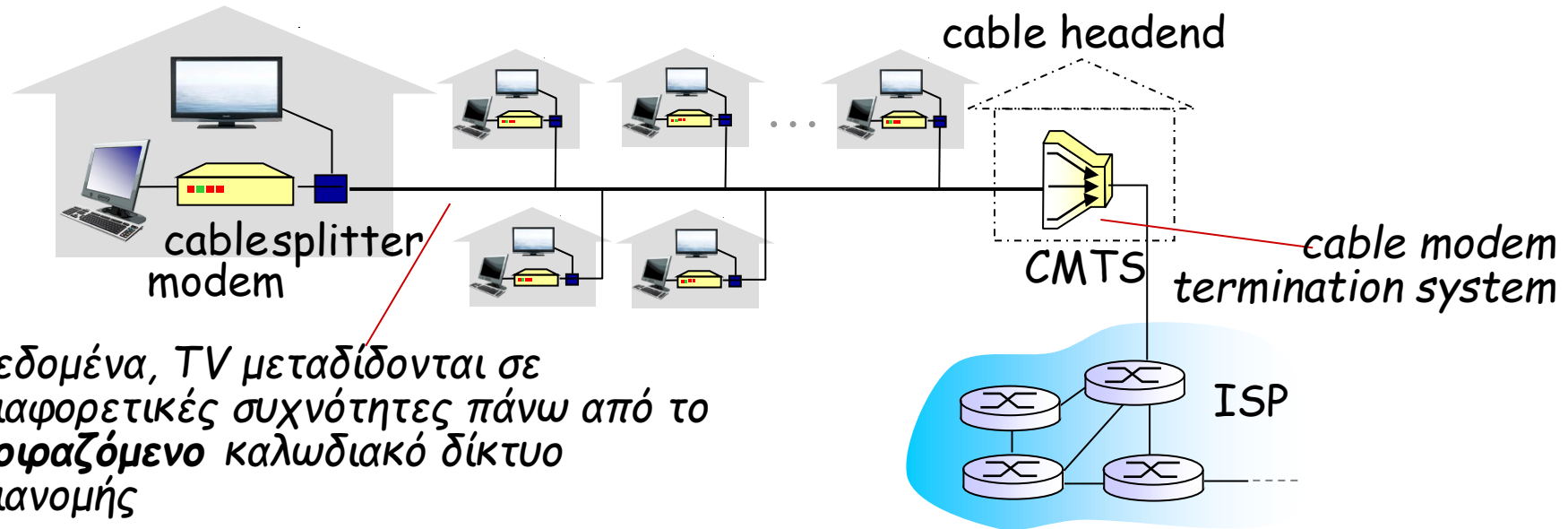

δεδομένα, TV μεταδίδονται σε διαφορετικές συχνότητες πάνω από το μοιραζόμενο καλωδιακό δίκτυο διανομής

❖ HFC: hybrid fiber coax

- ασύμμετρο: ρυθμός μετάδοσης μέχρι 30Mbps downstream, 2 Mbps upstream

❖ Δίκτυο από καλώδιο και οπτική ίνα συνδέει τα σπίτια με τον δρομολογητή ISP

- Τα σπίτια μοιράζονται το δίκτυο πρόσβασης μέχρι το καλωδιακό κέντρο τερματισμού

Αντίθετα το DSL προσφέρει αποκλειστική πρόσβαση



Πρόσβαση: οικιακό δίκτυο

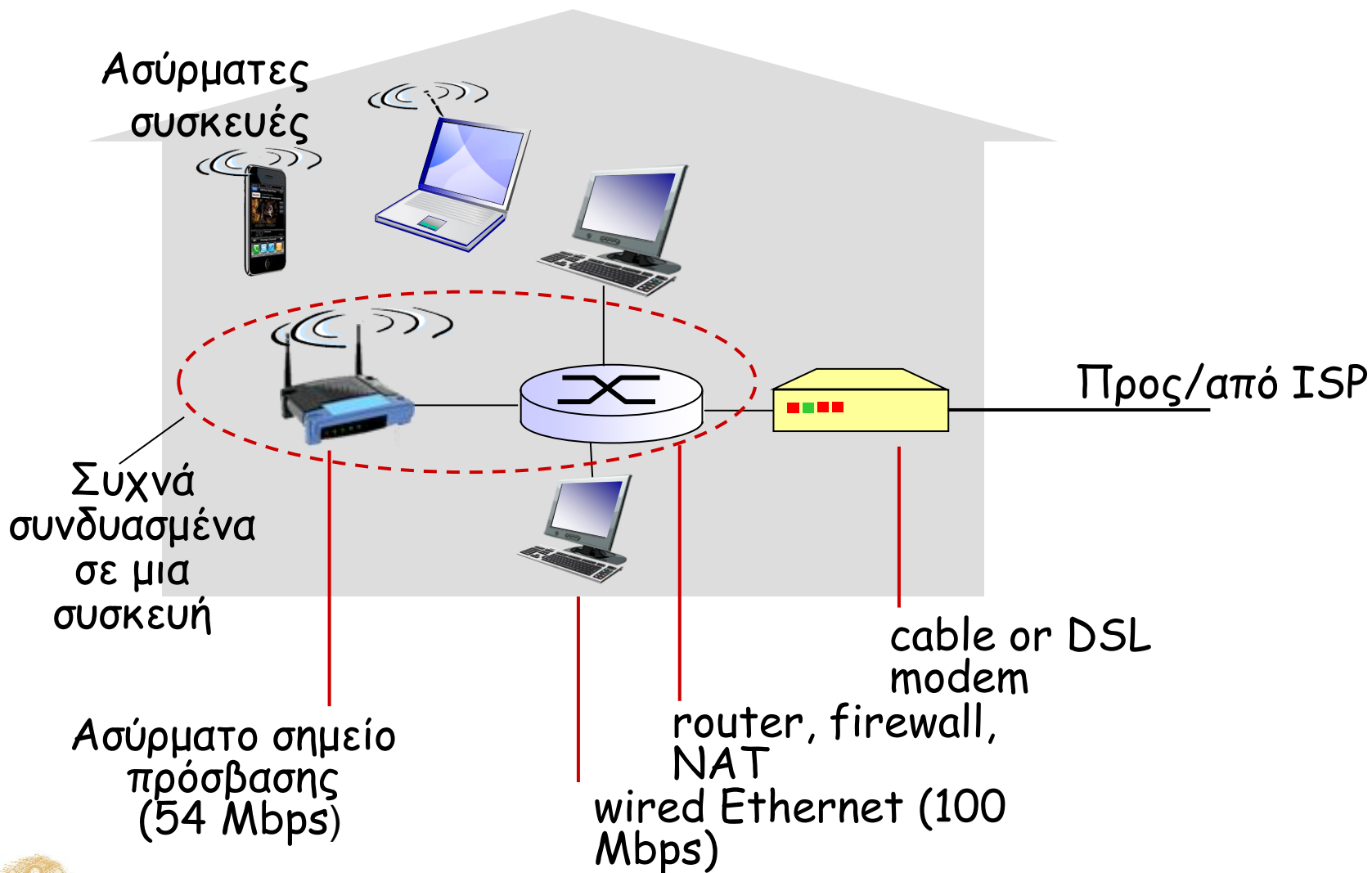

Δίκτυα πρόσβασης επιχειρήσεων (Ethernet)

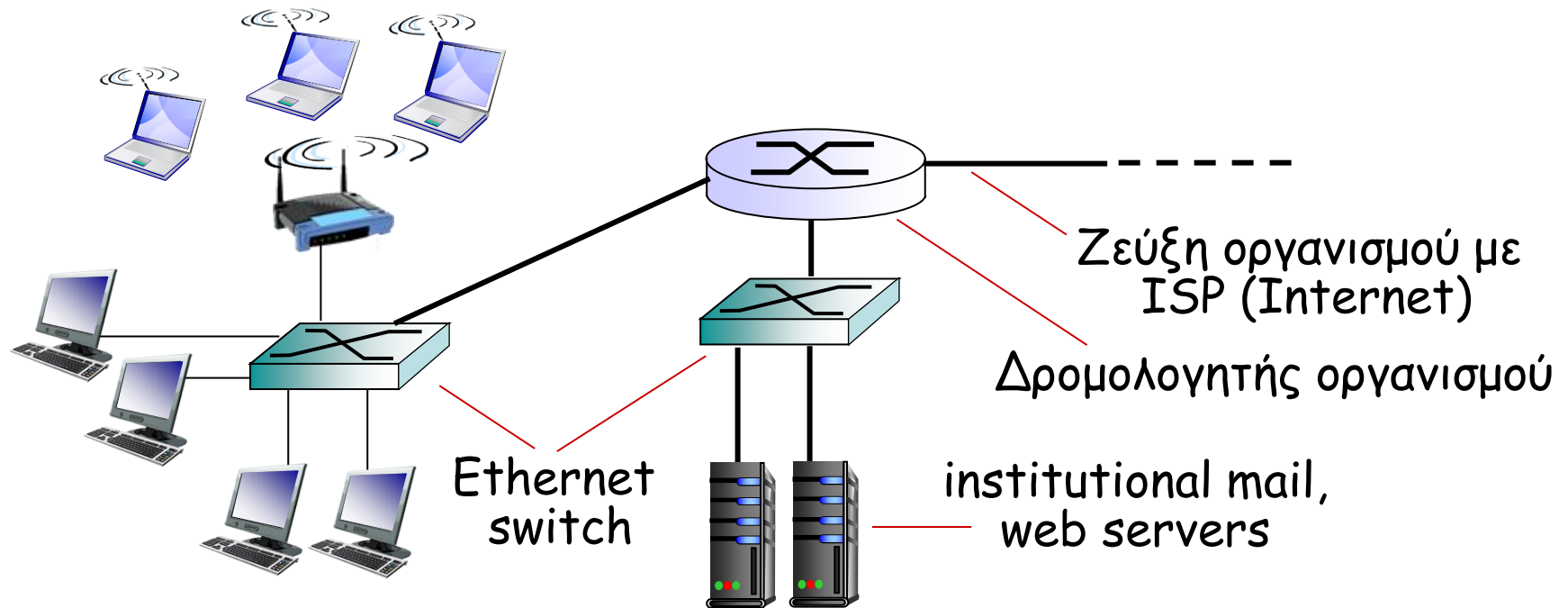

- ❖ Τυπική χρήση σε εταιρείες, πανεπιστήμια, κλπ
- ❖ Ρυθμοί μετάδοσης 10 Mbps, 100Mbps, 1Gbps, 10Gbps
- ❖ Σήμερα, τα τερματικά συστήματα συνδέονται σε μεταγωγείς Ethernet



Δίκτυα ασύρματης πρόσβασης

- ❖ Διαμοιραζόμενο δίκτυο ασύρματης πρόσβασης συνδέει τερματικά συστήματα με δρομολογητή
 - Μέσω σταθμού βάσης («σημείου πρόσβασης» - Access Point)

Ασύρματα LANs:

- Εντός κτιρίων (100 ft ή 30 m)
- 802.11b/g (WiFi): 11, 54 Mbps

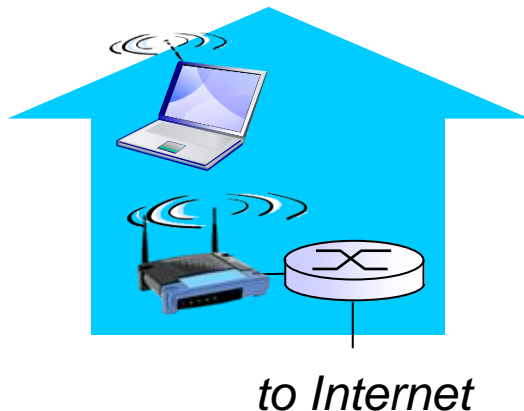

Ασύρματη πρόσβαση ευρείας περιοχής WLAN:

- Παροχείς κυψελωτών συστημάτων, 10' s km
- μεταξύ 1 και 10 Mbps
- 3G, 4G: LTE Σήμερα και 5G

